

Solving IB-type Exam Questions Using *fx-CG50*

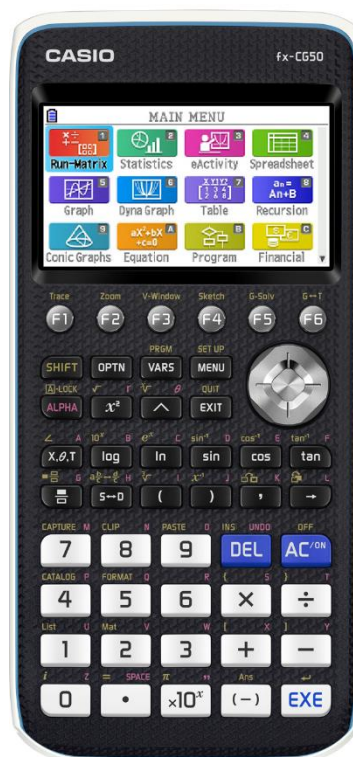

Ibrahim Wazir

Contents

Chapter 1 Introduction	3
MAIN MENU Screen.....	4
Basic Settings and Simple Calculations	7
Settings	7
Simple Calculations.....	9
Editing commands.....	10
Example:.....	10
Solution:	10
What to write during the exam?	13
Some Examples	15
Chapter 2 Solving Equations	37
Graphs and Tables	37
Equation-Solver.....	38
System of simultaneous equations.....	39
Polynomial equations	42
General Equations (Solver)	46
IB-type Exercises	47
Chapter 3 Calculus	79
Graphing.....	79
Calculus concepts	82
IB Question Types.....	83
Numerical derivatives, equation of tangent and normal lines	83
IB Question Types.....	92
Basic graphing concepts	92
Chapter 4 Probability-Statistics	151
IB Question Types.....	158
<i>The first four examples are for Math Studies students. The rest are either Math SL or Math HL + Option 7.</i>	158

Chapter 1 Introduction

This booklet aims to help students (and teachers) work through the mathematical methods in the IB Math Examinations and work using Casio's *fx-CG50*. (It can also be used for other examination boards' work).

As you will see, the *fx-CG50* is a powerful and rich tool. It will help you tremendously in performing a large number of operations needed for the exams. A remarkable feature of this gdc is that it provides you with more than one way to get your work done. The examples given in this booklet will demonstrate this fact by not offering you the "one-way" of performing calculations.

This is **not** a user manual for the *fx-CG50* as it focuses mainly on problem types that usually appear in IBO Math Examinations. The booklet assumes some basic skills in working with the *fx-CG50*. New users should get acquainted with to the "Quick-Start" section of the "Owner's Manual". Online manuals are also available. This is **not** an IB syllabus guide either. We will discuss several IB-type questions without the claim to cover all syllabi.

In this document we will address some of the issues and questions facing teachers and students. These include the following.

- How to use the *fx-CG50* to enrich instruction and learning,
- On exams, what students should write down when they use the *fx-CG50* or any other GDC.

The booklet is divided into different parts

1. Introducing the *fx-CG50* and its use in dealing with basic operations
2. Solving Equations (and inequalities)
3. Calculus
4. Statistics

Most of the exercises given are very similar to IB questions used in previous exams. For each problem, you will be given a suggestion of what you may write on the examination paper to get the best possible score and then a suggestion of a key sequence that helps you with the solution. Please note that there may be other methods to attain the same results. The methods presented here are not necessarily the finest or the simplest of the choices available.

Tip: A very important principle you need to keep in mind is that, you, the user of this calculator, or any other calculator, are the decision maker. This means that, even though you own a very powerful tool, but this tool may prove to be inefficient at times. In many situations, you will be faster and more accurate than the gdc itself. This is why we suggest that, before you start "punching" keys, ask yourself the question:

"Can I do this calculation faster than my gdc?"

If your answer is yes, then do not use it.

The *fx-CG50*



MAIN MENU Screen

The MAIN MENU screen contains the applications which allow the use of the different operations. You access this menu by scrolling to the ρ key and pressing 1, or while in the MENU screen by simply pressing the number that corresponds to the application. For example, the RUN-MATRIX application you press 1. Here is a list of some of the main applications we will be using on exam papers:



This is the main application for doing basic calculations. This app. allows the *fx-CG50* to be used like an advanced scientific calculator. Operations include numerical derivation and integration, random numbers and combinatorics, and matrix arithmetic.



This is the Statistics application. It caters for data entry in lists; graphs –Scatter plots, xy-line, Pie chart, Histograms, etc.; calculations including 1-variable and 2-variable statistics, as well as regression; hypothesis testing including Z, t, F, etc.; confidence intervals, calculating areas under several distributions, etc.



This is the Spreadsheet application. This application enables you to enter data in spreadsheet form, graph data stored in spreadsheet format, and do all the calculations listed in the STATISTICS app.



This is the Graph application. It allows you to draw graphs of functions including parametrically defined ones and polar graphs. You can also graph inequalities.



This is the Dynamic graphics application. You represent functions that contain parameters and study the effect of changing values of these parameters on your graphs.

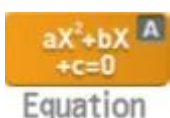

This is the Equation application. We use this mode to solve systems of linear equations with up to six unknowns, and polynomial equations with up to sixth degree.



We use this application to transfer memory contents or data to other units or to PC.



We use this menu to access basic system settings like display brightness.



We use this application to draw and explore geometric objects.



We use this to plot points (given by coordinates) and perform various types of analysis based on the plotted data.

There are also other applications that include “Table”, “Recursion”, “Conic Graphs”, “Program”, “eActivity”, etc.

Basic Settings and Simple Calculations

You can access any application from the Main Menu. You can always get to the Main Menu by pressing \square from any application window.

Settings

To set the GDC according to your preferences, you will need to go to the **System** application.



In the main menu screen, scroll down to **System** and press 1. Alternatively Press a or La.

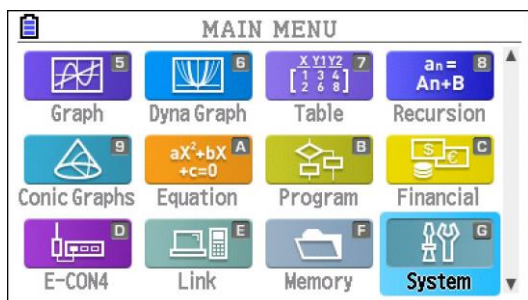

With the **System** setting you can manage Display Settings, Power Properties, Language, Battery Settings, and OS Update.

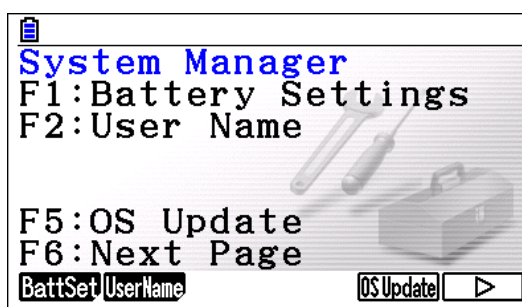
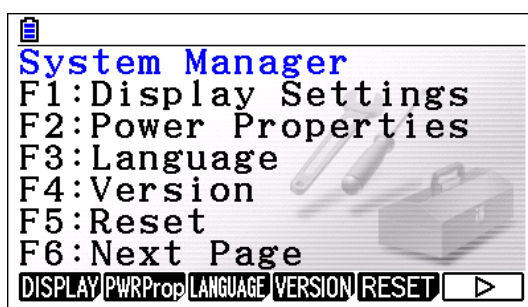

Also, while you work with an application, you can manage the basic settings of that application by going to the **SET UP** (Lp).



For example, when you are in the **Run-Matrix** application, the SET UP will help you manage Input/Output, Fraction Result, etc, as shown below.

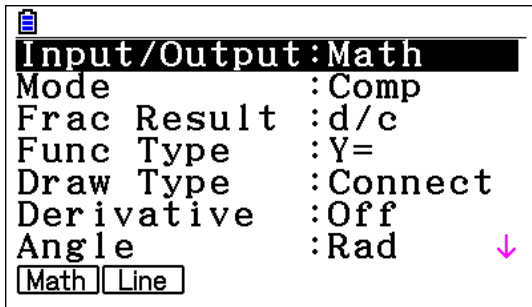

If you are in **Statistics** (**Statistics**) application, the SET UP window will look as shown below.

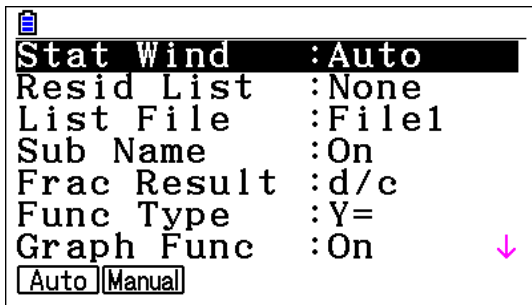

The **SET UP** will also look slightly different with each application.

Simple Calculations

If the **Input/Output** mode in **SET UP** is **Math**, calculations, when possible, are all shown in exact form

(By default the *fx-CG50* uses Natural Display.)

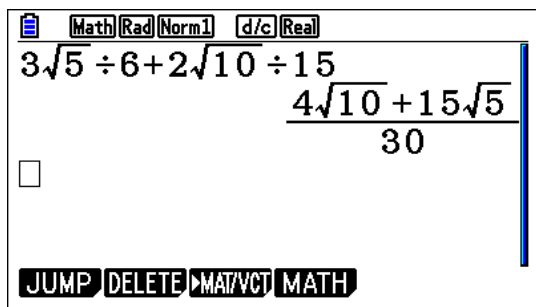

If you need the answers in approximate form, then after the result is given, press \square and you will get the answer in approximate form

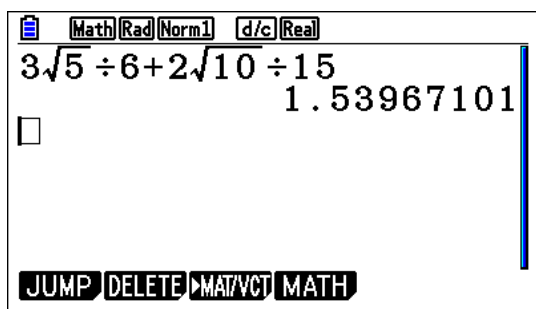

It may also be worth mentioning that you can enter expressions containing fractions in their “natural form”, i.e., the expression above can be entered as follows

First press \square

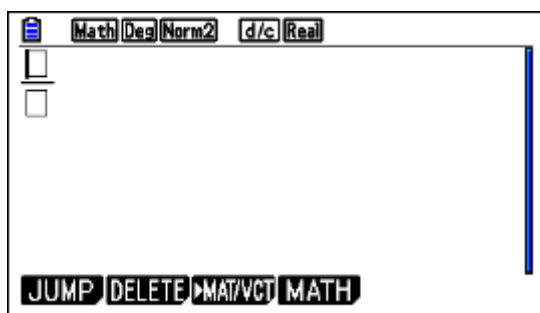

Then enter the expression and evaluate. You can scroll between the numerator and denominator by using \square .

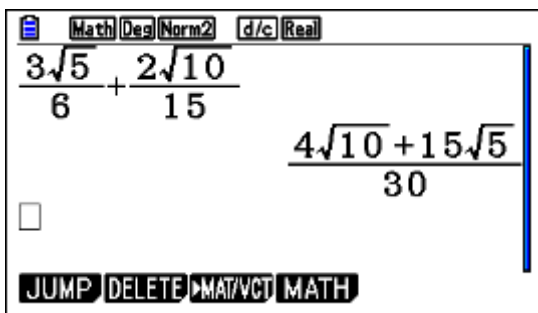

Editing commands

In **Run=Matrix** app., you can access previous commands (if you have not deleted them already!). If you move the cursor to a previous command, you can enter the command again by pressing \downarrow , or you can edit it by using \uparrow and then press \downarrow . Thus, if you need to change what you entered (for example, 7 instead of 2) without retyping the whole expression, just scroll up \uparrow to the original input, make the change and press \downarrow .

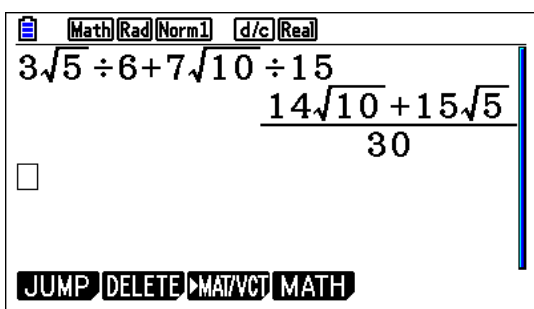

Example:

Solve the equation $|3x + 5| = 1$ over the set of real numbers.

Solution:

This is a basic equation involving absolute value.

fx-CG50, like other GDCs will immediately give you a solution.

First, from the main menu go to  (make sure that it is in Real mode),

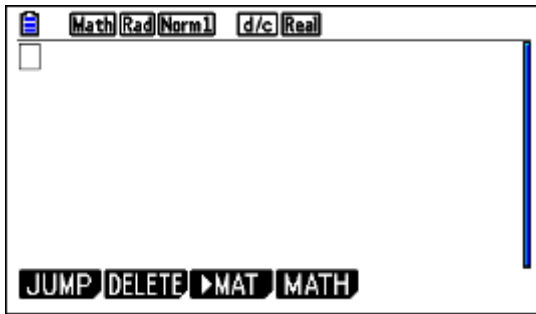

Press \square followed by \square leads you to **Solve**. Press \square

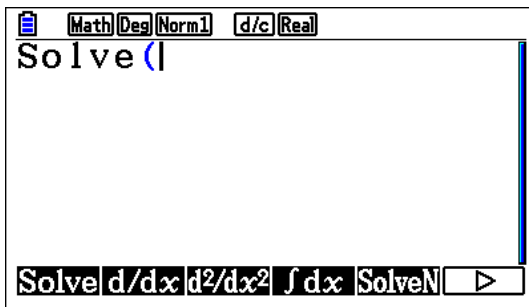

next, press \square (For the absolute value)

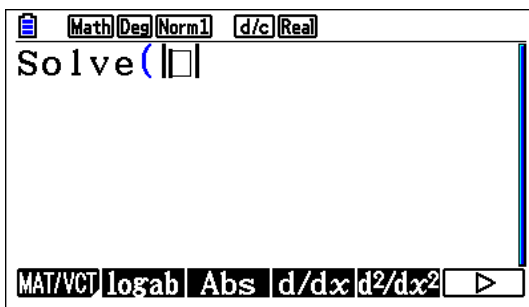

Type the equation: $|3x+5|=1$, x press \square to solve for x .

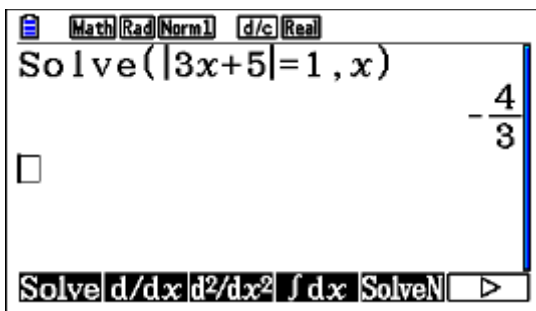

However, like any tool you have, accepting an answer without care will lead you to incomplete answers!

Knowing that the equation contains an absolute value, perhaps a better approach would be to first graph it, look for any hidden behaviour, then ask for the solution.

In this case the graph of the function $f(x) = |3x+5|-1$ is given below

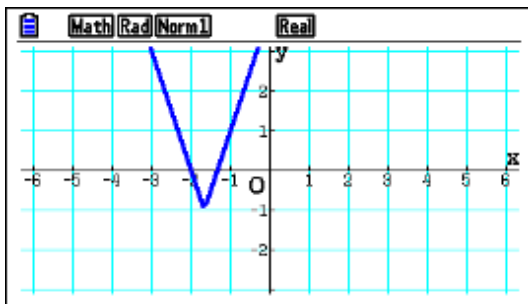

This indicates that there are two solutions; one is at -2 or close to it and one is close to -1 .

Now you can have all solutions:

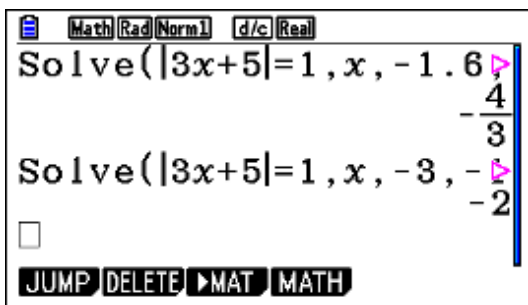

A better method in such cases would be to choose “SolveN” instead-no need to specify lower and upper bounds.

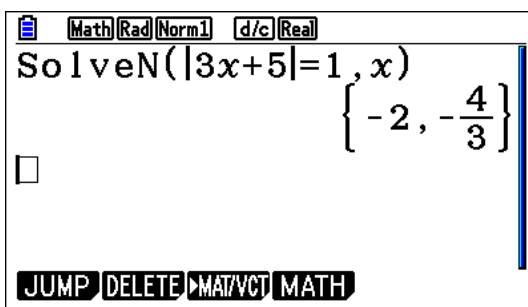

In fact, if the equation has only one variable, then there is no need to specify the variable you want to solve for!

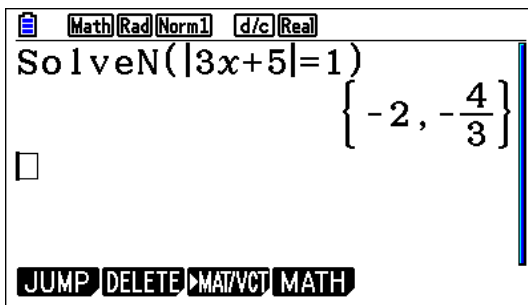

What to write during the exam?

In what follows we are producing some examples of what is expected of candidates to communicate on an exam question in the presence of a GDC. This is not meant to be prescriptive, it is a guide to clarify the frequently asked question of “what should I show” on an exam paper.

The following introductory remarks depend on the results of research work done at several institutions, but borrow mainly from the research at The University of Melbourne.

An essential point that has to be observed is that examiners should be able to read and understand a piece the student work without doing the technology work themselves. So examiners should be able to follow how the candidate has gone from line to line without a need to the GDC’s screen dumps.

In general, the candidate will need to write down the “formulation of the mathematical problem and the interpretation of the answer.” Candidates are not expected to describe what they did on the GDC.

It is suggested that a student you should:

- “1. Write down all of your reasons;
- “2. Write down all the information that you use, including what you input into the” GDC;
- “3. Make sure that the plan of the solution is clear so that the solution path can be easily followed;”
- “4. Write down selected answers only – not every intermediate answer need be recorded.”

Each question in this booklet has a recommended “exam-response”. Your responses are not expected to contain screen shots of the calculator screen. This is followed by details of GDC use. The type of calculator used is irrelevant, but the screen shots shown here are for Casio’s *fx-CG50*. There are several problems where the GDC solution is quite inefficient. However, these questions are presented here as an example of what kind of written response is expected.

Hint: Remember the wording in questions indicates whether only a gcd solution is enough, or you need to show work. Here are some of the definitions of the “command terms” as they appear in the HL Math IB guide. Comments in *italics* are the author’s.

Calculate	Obtain a numerical answer showing the relevant stages in the working. <i>GDC will help, but some work has to be shown.</i>
Draw	Represent by means of a labelled , accurate diagram or graph, using a pencil. A ruler (straight edge) should be used for straight lines. Diagrams should be drawn to scale. Graphs should have points correctly plotted (if appropriate) and joined in a straight line or smooth curve. <i>GDC will help. You can produce the graph from your gcd’s screen, but you have to label it correctly.</i>
Estimate	Obtain an approximate value. <i>GDC answer is fine.</i>
Find	Obtain an answer, showing relevant stages in the working. <i>GDC will help, but some work has to be shown.</i>
Sketch	Represent by means of a diagram or graph (labelled as appropriate). The sketch should give a general idea of the required shape or relationship, and should include relevant features. <i>GDC will help.</i>
Solve	Obtain the answer(s) using algebraic and/or numerical and/or graphical methods. <i>GDC will help</i>
State	Give a specific name, value or other brief answer without explanation or calculation. <i>GDC answer is fine.</i>
Write down	Obtain the answer(s), usually by extracting information. Little or no calculation is required. Working does not need to be shown. <i>GDC answer is fine.</i>

Some Examples

Example 1

Tim stands at the Danube river bank, T , and watches a truck R and a car C on the opposite bank as shown. A point B , directly opposite to Tim on the opposite side is 150 meters away.

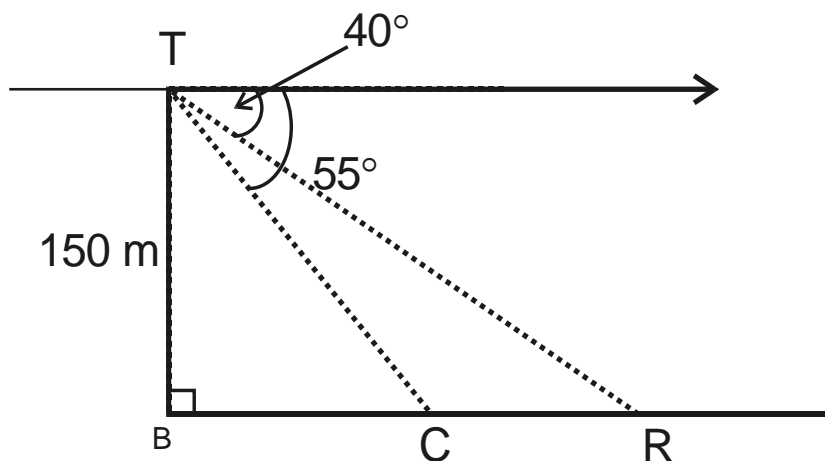

- Calculate, RB , the distance between the truck and the point B .
- Calculate, RC , the distance between the truck and the car. Give your answer correct to the nearest meter.

Exam response:

- In right triangle RBT , $\angle RTB = 90^\circ - 40^\circ = 50^\circ$

$$\text{Hence } \tan 50 = \frac{RB}{TB} \Rightarrow RB = 150 \times \tan 50 \approx 178.8 \text{ m}$$

- Since $\angle CBT = 90^\circ - 55^\circ = 35^\circ$, then

$$\text{In right triangle } CBT, \tan 35 = \frac{CB}{TB} \Rightarrow CB = 150 \times \tan 35 \approx 105$$

$$\text{Therefore } RC \approx 179 - 105 = 74\text{m}$$

fx-CG50

- both parts are straight-forward calculations

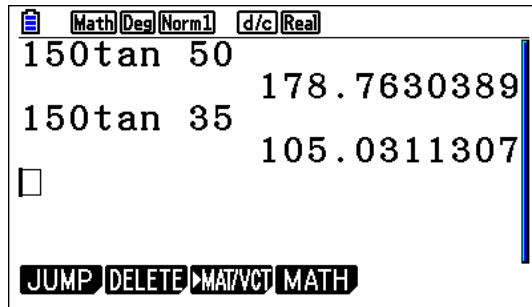

Note: Results that you need to retrieve for future use can be stored in *memories* [A to Z]. For example, in the previous result, we can store the first result in **A** and the second result in **B** and then subtract them as shown below. This way, we can keep all “intermediate” answers without rounding so that our final answer comes out with less potential of “rounding” error.

To store a result that is already showing, first press **b**. This will apply to a number you have just entered or to the result of a calculation just finished. Now press **a** followed by any letter. In our case, we stored the first result in **A** and the second one in **B**.

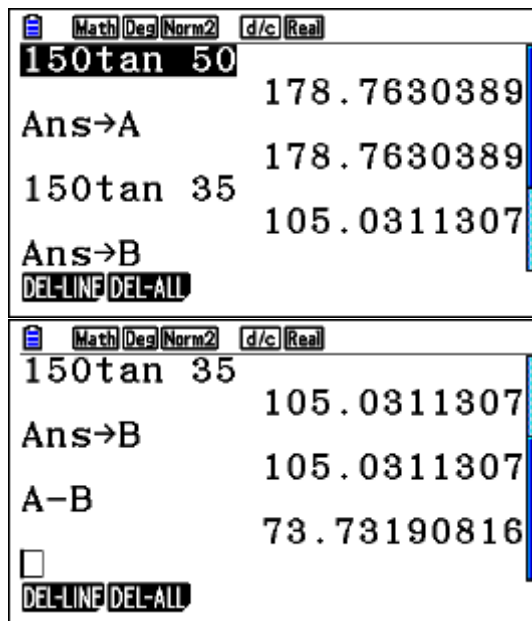

To change the value of a memory variable, just store another number into it. Storing overwrites any existing value.

Example 2

Andreas invests 8000 euros in an account which pays a nominal annual interest rate of 5.25% , compounded monthly. Give all answers correct to two decimal places.

Find

- the value of the investment after 5 years;
- the difference in the final value of the investment if the interest was compounded quarterly at the same nominal rate.

Exam response:

- The value of the investment after 5 years is

$$A(t) = P \left(1 + \frac{i}{n} \right)^{nt} = 8000 \left(1 + \frac{0.0525}{12} \right)^{12 \times 5} = 10395.46$$

- If the interest was compounded quarterly, then the amount would be

$$A(t) = P \left(1 + \frac{i}{n} \right)^{nt} = 8000 \left(1 + \frac{0.0525}{4} \right)^{4 \times 5} = 10383.66$$

The difference is $10395.46 - 10383.66 = 11.80$

fx-CG50

This work can be performed in several ways. We will show one here.

- Go top, scroll to **Financial** app, 1

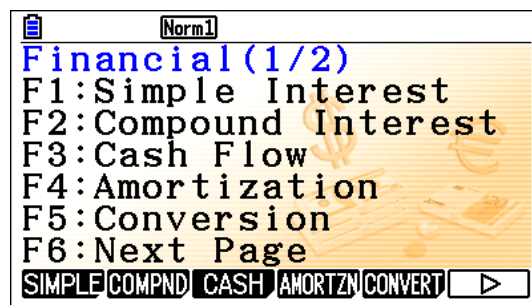

Press w and type the numbers in followed by 1 each time (remember that the present value = investment is entered as a negative number!)

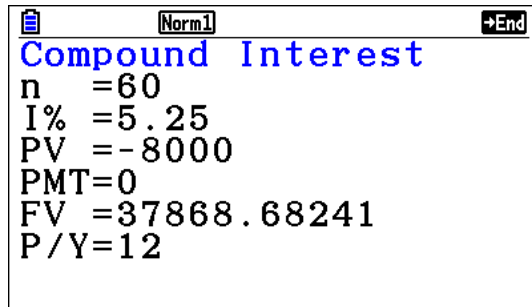

Note: There may be a number corresponding to FV there. Ignore it.

Press y for FV (Future value)

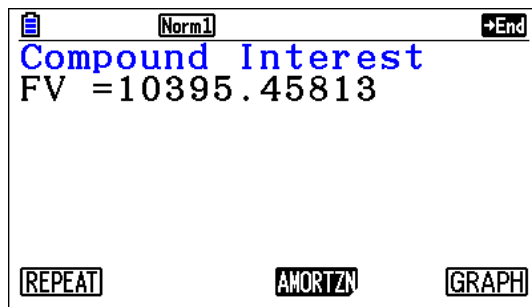

- b. Press q for REPEAT and type in the new numbers.

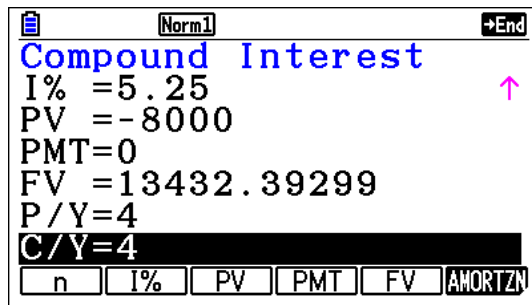

Press y

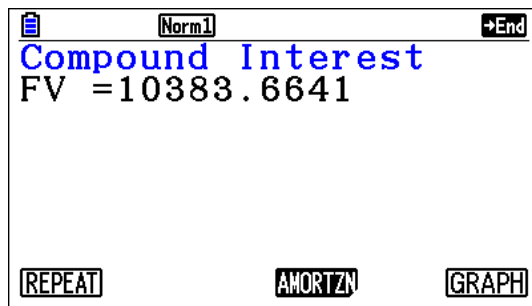

Example 3

An automatic coffee machine heats the water to prepare your coffee such that the water temperature, T , after 30 seconds is 35°C and after 50 seconds the water temperature is 60°C .

The water temperature at time t can be modelled by $T = mt + b$, where t is the time in seconds after starting the heating process.

- Find two equations in m and b .
- Solve the system for m and b .
- Use the model to predict the temperature of the water after 1 minute.

Exam response:

- The first equation corresponds to the 30 seconds: $35 = 30m + b$

The second equation corresponds to the 50 seconds: $60 = 50m + b$

- If we subtract the two equations:

$$25 = 20m, \text{ thus } m = \frac{5}{4} \text{ and } b = -2.5$$

- The equation is now

$T = \frac{5}{4}t - 2.5$. Hence we can predict the temperature after 1 minute (60 seconds) to be 72.5.

fx-CG50

This question shows that, even though a gcd can be used, but in fact it is not necessary!

- a non-gcd question.
- We can use the **Equation** app.

From the main menu go to  and press $\square\square$

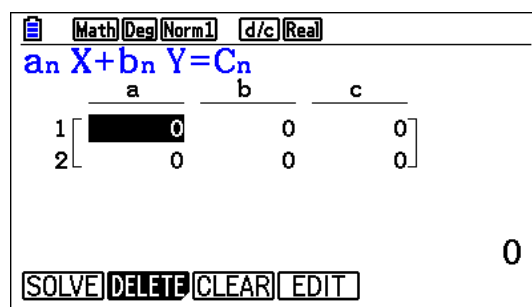

Type the numbers in, pressing \downarrow after each value

Math				Deg				Norm1				d/c				Real			
a _n X + b _n Y = C _n																			
				a				b				c							
1	[30	,	1	,	35]												
2	[50	,	1	,	60]												
														60					
SOLVE																			
DELETE																			
CLEAR																			
EDIT																			

Press \square

Math				Deg				Norm1				d/c				Real			
a _n X + b _n Y = C _n																			
X				1.25															
Y				-2.5															
														$\frac{5}{4}$					
REPEAT																			

- c. This is a direct substitution into the equation.

Example 4

Consider the arithmetic series: $3 + 7 + 11 + \dots$

- Find an expression for S_n , the sum of the first n terms.
- Find the value of n such that $S_n = 3916$

Exam response:

- The formula for the partial sum of an arithmetic series is

$$S_n = \frac{n}{2}(2a_1 + (n-1)d)$$

In this case, $a_1 = 3$ and $d = 4$. Hence

$$S_n = \frac{n}{2}(2a_1 + (n-1)d) = S_n = \frac{n}{2}(6 + 4(n-1)) = n(2n+1)$$

- if $S_n = 3839$, then $n = 44$

fx-CG50

In the **Run-Matrix** application menu, press the sequence: `irY` which leads you to the **SolveN** menu. Type the equation `f(2f+1) L. 3916) L [x(2x + 1) = 3916` in, close the bracket, and press `]`.

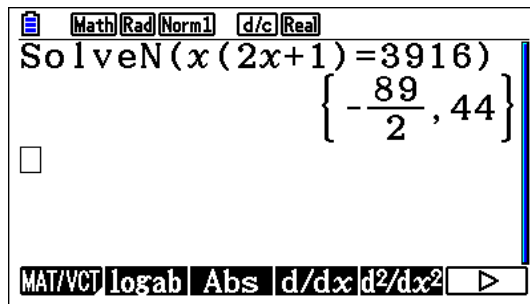

As you notice, there are two solutions. Obviously you choose the positive integer 44.

Note: There is no need to type the multiplication signs between variables in algebraic expressions. The *fx-CG50* will handle the algebraic expressions as you normally write them.

Example 5

Two ships A and B start from the same port. Ship A moves West at a constant speed of 25 km/h and ship B moves in a direction N 50°E (clockwise from the North direction) at a constant speed of 30 km/h. How far are the two ships after two hours?

Exam response:

The diagram shows the two ships two hours after leaving the port.

Ship A moved 50 km W, and ship B moved 60 km NE.

The required distance is AB which can be found by using the law of cosines:

$$AB = \sqrt{50^2 + 60^2 - 2 \times 50 \times 60 \times \cos 140^\circ} \approx 103.423 \text{ km}$$

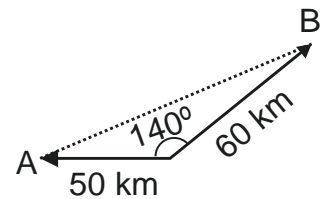

fx-CG50

In the **Run-Matrix** application menu, press the sequence:

↳ 50s + 60s - 2m50m60mj 140, then ↵

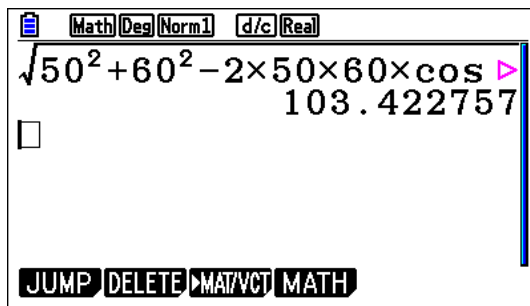

Note: As you can see above, if a command is too long to fit on the screen the *fx-CG50* automatically shows arrows on the display to indicate the fact. If you need to check or edit what you have already entered, you can move backwards or forwards with ! and \$ cursor keys. If the cursor is at the left end and press !, it will jump to the right end and vice versa. When you edit an expression and then from anywhere in that expression you press ↵, the expression will be recalculated.

Example 6

Find the angle between the two vectors $u = 2i - 3j + 2k$ and $v = i + 2j - 3k$.

Exam response:

The angle between two vectors can be found by using the connection between the two interpretations of the scalar product (law of cosines). That is

$$u \cdot v = (u_1, u_2, u_3) \cdot (v_1, v_2, v_3) = |u||v| \cos \theta$$

$$\Rightarrow \cos \theta = \frac{u \cdot v}{|u| \cdot |v|} = \frac{u_1 v_1 + u_2 v_2 + u_3 v_3}{\sqrt{u_1^2 + u_2^2 + u_3^2} \sqrt{v_1^2 + v_2^2 + v_3^2}}$$

$$\Rightarrow \theta = \cos^{-1} \left(\frac{u_1 v_1 + u_2 v_2 + u_3 v_3}{\sqrt{u_1^2 + u_2^2 + u_3^2} \sqrt{v_1^2 + v_2^2 + v_3^2}} \right) = \cos^{-1} \left(\frac{2 - 6 - 6}{\sqrt{4 + 9 + 4} \sqrt{1 + 4 + 9}} \right) = 130.406$$

fx-CG50

In the **Run-Matrix** application menu, press \square (**MAT/VCT**), scroll to the vector name you want to use and press \square

You receive the following submenu

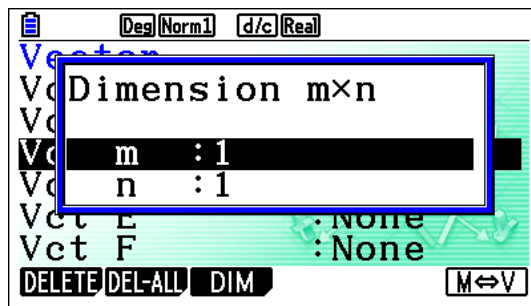

Type 3 for m and 1, then 1 for n and 1. Now fill the components of the first vector

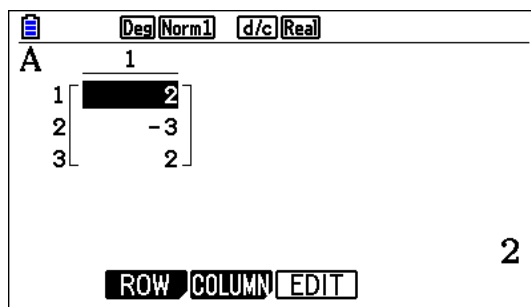

Do the same for the second vector

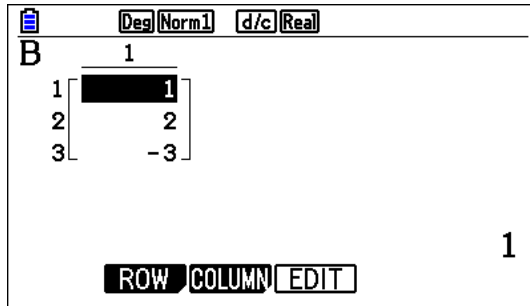

Now, d and i followed by w and uu and then r(Angle).

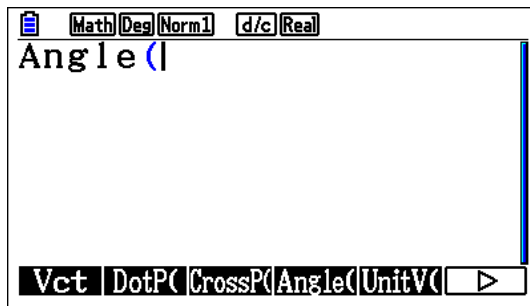

Now q(Vct), then choose A, insert “,” and then q again and choose B and close the brackets and 1.

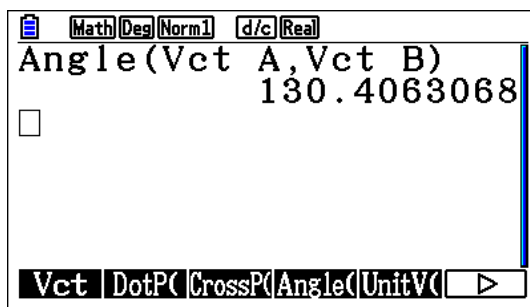

Alternatively, we can get the angle by performing the steps in the analytic solution above.

That is finding $\cos^{-1}\left(\frac{u \cdot v}{|u| \cdot |v|}\right)$.

After entering to components of the vectors, do the following

Lj, then open brackets, then iw, uu eq A, q B, close brackets, and 1.

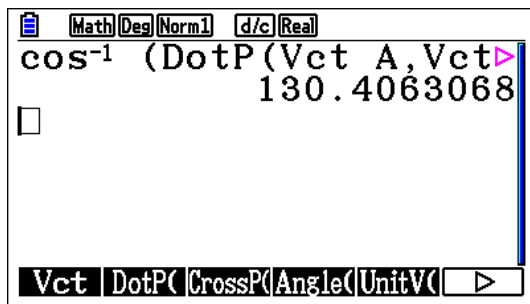

Example 7

The diagram shows two concentric circles with radii of 10 and 7 cm. the shaded region is 53.41 cm^2 . Find the measure of the central angle α , giving your answer to the nearest degree.

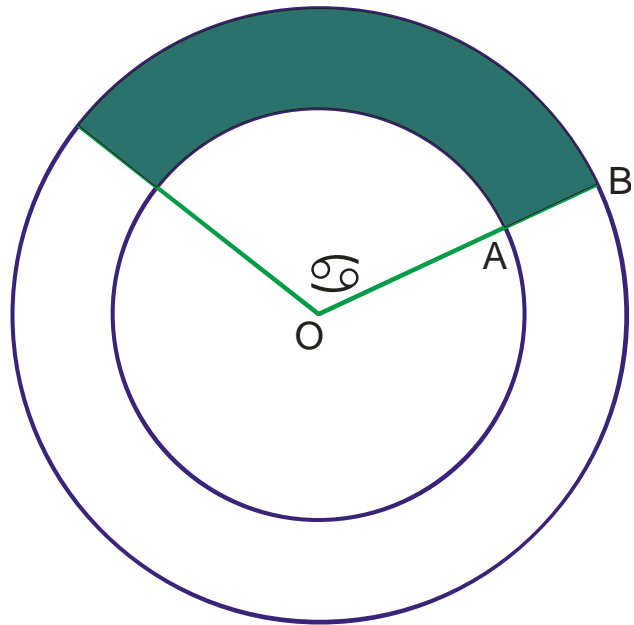

Exam response:

The shaded region is the difference between the sector of the large circle and the sector of the smaller one.

Hence, this area is given by the following expression:

$$53.41 = \frac{1}{2} R^2 \alpha - \frac{1}{2} r^2 \alpha \text{ when the angle is in radians.}$$

$$\text{Thus } \alpha = \frac{2 \times 53.41}{10^2 - 7^2} \approx 2.095 \text{ radians and so } \alpha \approx 120^\circ.$$

fx-CG50

In the **Run-Matrix** menu, press the sequence `iry (SolvN)`, then type in the equation

$$53.14 = 50x - 24.5x, \text{ and then } \downarrow, \text{ then } \text{m}180\text{M}\pi.$$

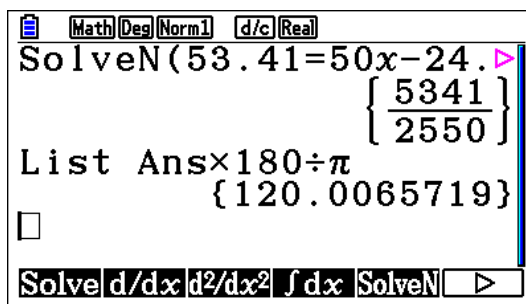

Example 8

In triangle IBO, IB = 8 cm, OB = 11 cm, and the area of the triangle is 38.105 cm. Find the two possible measures angle IBO.

Exam response:

We can use the law of sines area formula here, i.e, $Area = \frac{1}{2}io \sin B$

In this case $38.105 = \frac{1}{2} \times 11 \times 8 \times \sin B$

Thus $\angle IBO = \sin^{-1} \frac{2 \times 38.105}{11 \times 8} \approx 60^\circ$ or 120° .

fx-CG50

In the **Run-Matrix** menu, again press the sequence **iry** (**SolvN**), then type in the equation $38.105 = 11 \times 4 \times \sin x$, and then **1**

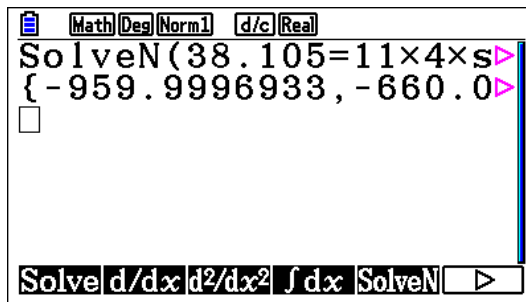

The screen shows several solutions. However, since the angle must be between 0 and 180, we scroll to the right to get the correct solutions as shown below

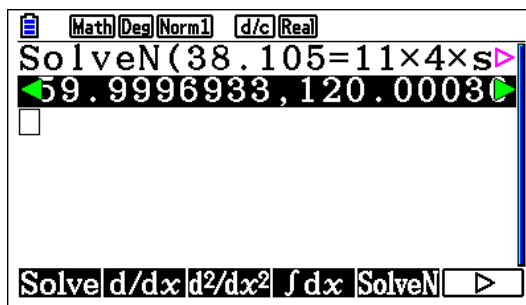

Also, since we have a restriction on the value of x , we can specify the restrictions in the **SolvN** window:

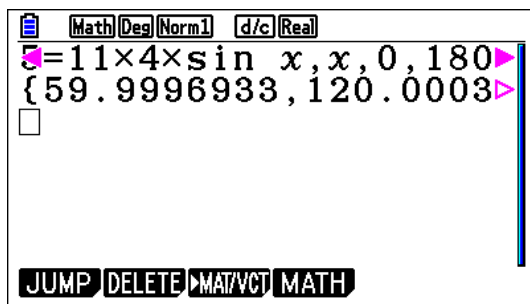

Example 9

In triangle ABC, $BC = 6$, $AC = 7$ and $\angle A = 30^\circ$. Find all possible values of AB .

Exam response:

We can use the law of sines.

$$\frac{\sin 30}{6} = \frac{\sin B}{7} \Rightarrow \sin B = \frac{7}{12}$$

This implies that B can have one of 2 values:

$$\square B = \arcsin \frac{7}{12} \approx 35.7^\circ;$$

$$\text{or } \square B = 180 - 35.7 = 144.3^\circ$$

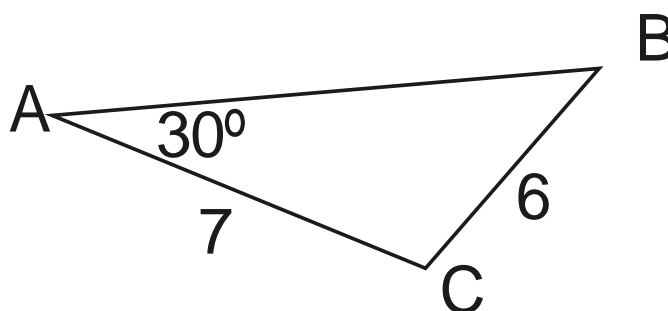

When $\angle B = 35.7^\circ$, $\angle C = 114.3^\circ$

Use the law of sines again

$$\frac{\sin 30}{6} = \frac{\sin 114.3}{AB} \Rightarrow AB = \frac{6 \sin 114.3}{\sin 30} \approx 10.9$$

When $\angle B = 144.3^\circ$, $\angle C = 5.7^\circ$

Use the law of sines again

$$\frac{\sin 30}{6} = \frac{\sin 5.7}{AB} \Rightarrow AB = \frac{6 \sin 5.7}{\sin 30} \approx 1.19$$

fx-CG50

In the **Run-Matrix** menu, again press the sequence **iry (SolvN)**, then type in the equation $\frac{\sin 30}{6} = \frac{\sin x}{7}$, $x, 0, 180$, and close brackets, and then **1**

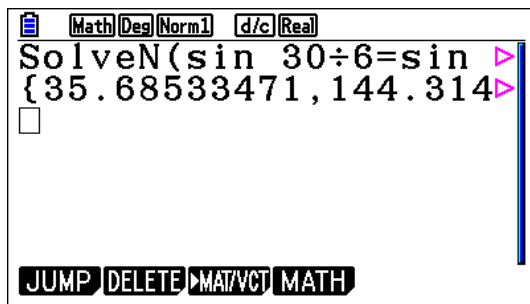

This gives you the values for PB.

PC can be easily found (not efficient to use the GDC!). Now, both values of AB can be found value corresponding to the values of PC by typing $\frac{6 \sin \{5.7, 114.3\}}{\sin 30}$ and **1**

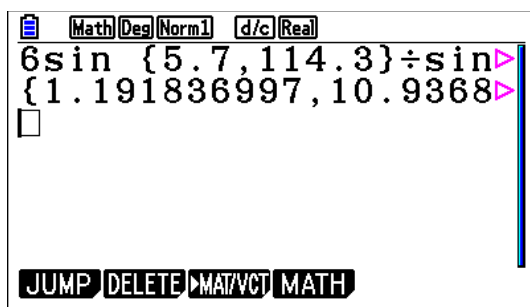

Example 10

A part of a track is shown in the diagram. The radius of the inner circle is 60 m, the width of the track is 3 m. The length of the inner arc is 20π and the outer arc is 21π . Find the area of the track.

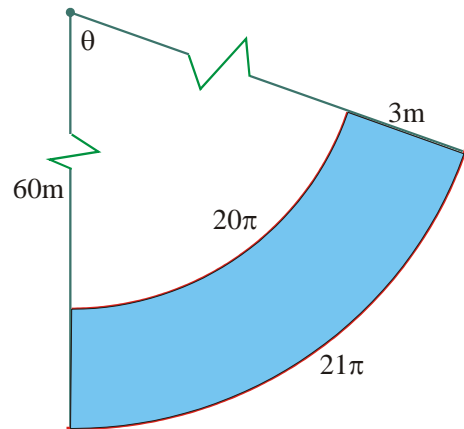

Exam response:

We need to find θ first.

Length of arc formula: $l = r\theta$, (θ in radians)

$20\pi = 60\theta$ and hence $\theta = \pi/3$.

The requested area is then: $\frac{1}{2} \times 63^2 \times \frac{\pi}{3} - \frac{1}{2} \times 60^2 \times \frac{\pi}{3} = \frac{123\pi}{2}$

fx-CG50

In the **Run-Matrix** menu, you simply type the expression in:

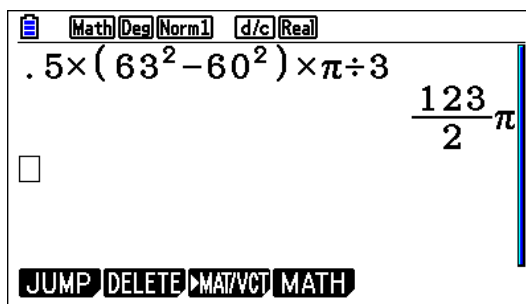

Example 11

An infinite geometric series converges to 24. The sum of the first three terms is $\frac{208}{9}$. Find the sum of the first 6 terms.

Exam response:

The sum to infinity of the geometric series is $\frac{a}{1-r} = 24 \Rightarrow a = 24(1-r)$

The sum of the first three terms: $a + ar + ar^2 = a(1+r+r^2) = \frac{208}{9}$

Thus, by substitution: $24(1-r)(1+r+r^2) = \frac{208}{9}$ and so $r = \frac{1}{3}$ and $a = 16$

Therefore the sum of the first 6 terms is $a \left(\frac{1-r^6}{1-r} \right) = \frac{5824}{243}$

fx-CG50

We use the **SolvN** again:

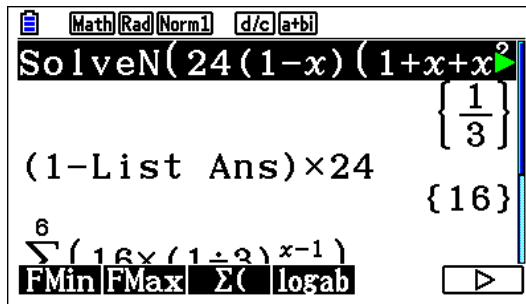

(Notice here that we use List Ans – L1 Ln because the answer is given in List form!)

The sum of the 6 terms is also given by putting the expression for the geometric sum in the summation notation as shown (To get to the summation notation follow the sequence `irue` and then fill in the numbers):

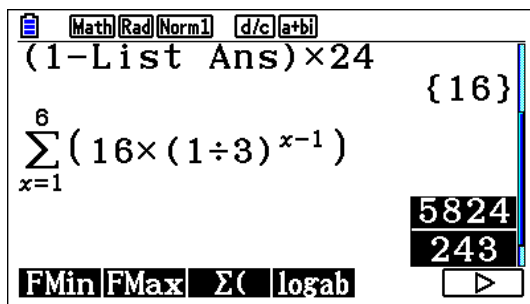

Example 12

You invest an amount of 1000 at an interest rate of 6% compounded semi annually. How much money will you have in 20 years?

If you were offered to invest the money at continuous compounding, how long will it take you to earn the same amount?

Exam response:

We use the compound interest formula to find the amount:

$$A(20) = 1000(1 + 0.03)^{20 \times 2} = 3262.04$$

For the second part, we use the continuous compound formula and solve for the time:

$$A(t) = 3262.04e^{0.06t} \Rightarrow t = 19.71$$

fx-CG50

We use the **Financial** menu

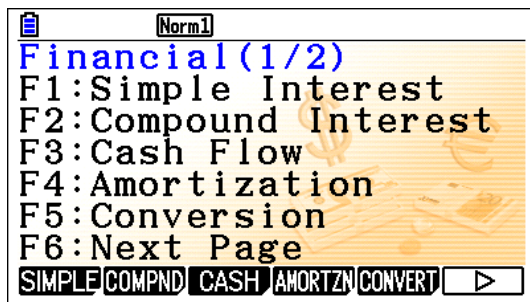

Press w for compound interest, you get a screen with several parameters

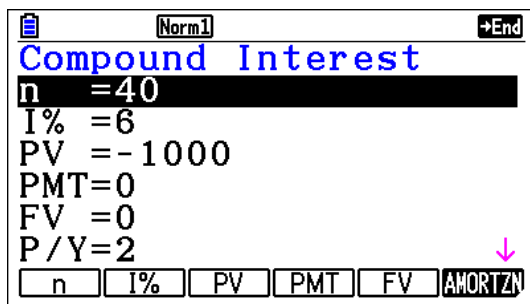

n is the number of compounding periods, I for the annual interest rate 6% is written as 6), PV is the Principal (notice that it is written as -1000), P/Y is the number of payments (or C/Y compounding intervals per year) – FV is future value.

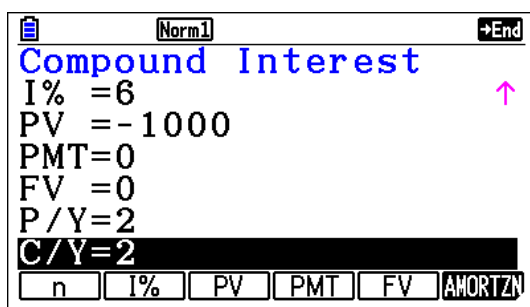

Press γ to get the amount

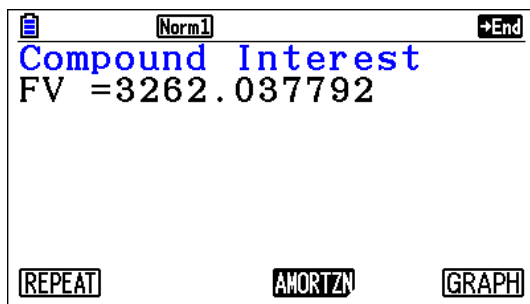

Now in the **Run-Matrix** menu, we go to **SolveN** again and type the equation

$$3262.037792 = 1000e^{0.06x},$$

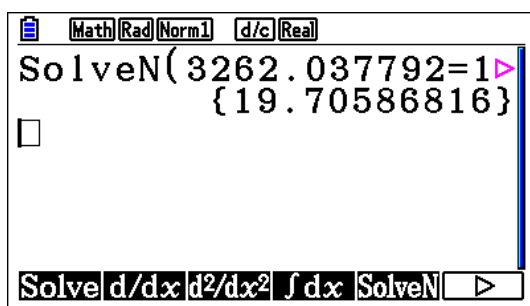

Example 13

In the expansion of $(4x - 3)^{11}$, the term in x^6 can be expressed as $\binom{11}{r} \times (4x)^n \times (-3)^m$.

- Write down the values of m , n , and r .
- Find the coefficient of the x^7 in this expansion.

Exam response:

- This is the 7th term in the binomial expansion, $r = 6$ (it can also be 4), $n = 6$, and $m = 5$.
- The coefficient corresponds to the integer in $\binom{11}{6} \times (4x)^6 \times (-3)^5 = -459841536$

fx-CG50

- In the **Run-Matrix** menu:

`iue11e6m4^6$mn3^5l`

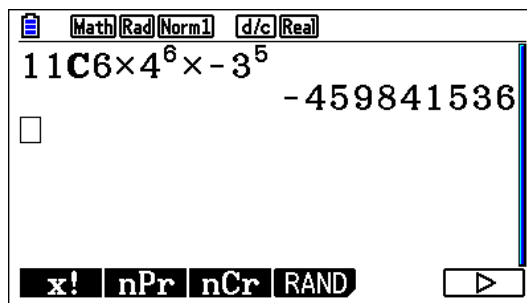

Example 14

The diagram shows a quadrilateral CASI inscribed in a circle with center O and radius 16 cm. Also, CA = 16 cm, AS = 23 cm, SI = 28 cm, $\angle ISA = 74^\circ$, and $\angle CAS = 102^\circ$.

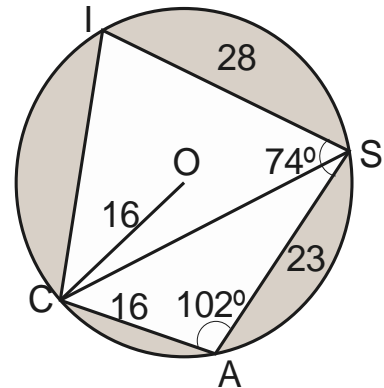

- Find CS.
- Find $\angle CSI$
- Find the area of triangle CAS.
- Hence or otherwise, find the area of the shaded region.

Exam response:

- We use the rule of cosines:

$$CS^2 = 16^2 + 23^2 - 2 \times 16 \times 23 \times \cos 102$$

$$CS = 30.6$$

- In order to find $\angle CSI$ we need to find $\angle CSA$.

We use the law of sines in triangle CAS.

$$\frac{\sin(\angle CSA)}{16} = \frac{\sin 102}{30.6} \Rightarrow \angle CSA = 30.8^\circ.$$

$$\text{Thus } \angle CSI = 74 - 30.8 = 43.2$$

- We use law of sines:

$$\text{Area} = \frac{1}{2} \times 16 \times 23 \times \sin 102 \approx 180.$$

- Required area is the area left after subtracting the areas of triangles CAS and CIS

$$\text{Shaded area} = \pi \times 16^2 - 180 - \frac{1}{2} \times 28 \times 30.6 \times \sin 43.2 \approx 331$$

fx-CG50

- a. We use the **Run-Matrix** menu.

Type in the expression as shown below.

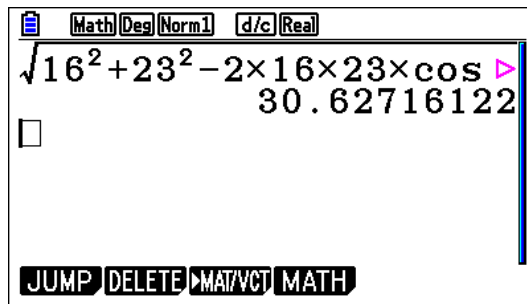

- b. From part b above it is clear that $\square CSA = \sin^{-1}\left(\frac{16 \sin 102}{30.6}\right)$ and
 $\square CSI = 74 - \square CSA$, thus the result can be achieved by typing

$$74 - \sin^{-1}\left(\frac{16 \sin 102}{30.6}\right)$$

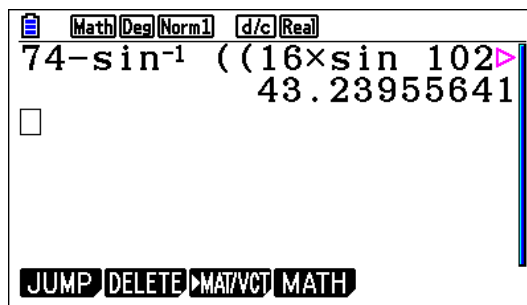

- c. Here the area is simply half the product of the two sides and the sine of the included angle.

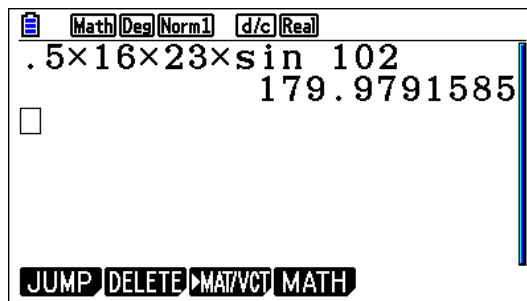

- d. The shaded area is the area of the circle minus the areas of the two triangles

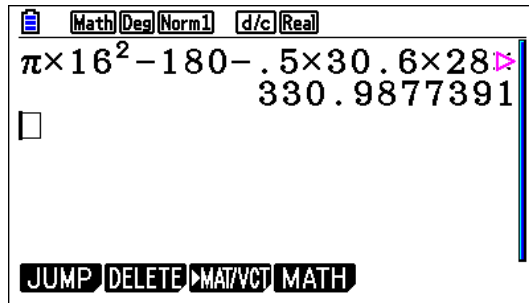

Chapter 2

Solving Equations



In this chapter, we will start working with our *fx-CG50* graphic display calculator by using it in solving equations type of questions that appear on examinations. Some problems may require work on other topics such as matrices for example, will also be briefly discussed.

As mentioned in the introduction, please remember three things

1. This document you are using is not a User's Manual for the calculator. The manual itself comes with the calculator when you bought it, or can be downloaded from Casio.
2. The instructions shown here are meant to introduce you to the use of this GDC and the methods suggested are not the only ways possible. In many cases, after gaining enough experience with the *fx-CG50*, you will be able to utilize its power in ways that fit your preferences.
3. On examinations, calculator language and screen dumps should not be used. Please read the suggestions given in the introduction. Screen dumps and calculator output are mentioned here for explanation purposes of the use of *fx-CG50* in answering IB-type of questions and are not meant as models of answers used on exams.

Graphs and Tables

As you know, working with equations, will, in many cases, involve working with functions. This is especially true when you try to find solutions to equations where an exact solution is not easily attainable. This is why we will start with the use of graphs and tables in this chapter. More detailed treatment will also appear in chapter 3.

From the main menu, press menu 5,  to access the symbolic menu for graphing and menu 7,  to access the same menu for table work. Basically you can store up to 20 functions (Y1 – Y20).

Recall that the functions should be expressed as $y = f(x)$. For example a function of the form $2x^3 - 3x + y = 7$ has to be first rearranged and then entered, i.e., $y = -2x^3 + 3x + 7$. Also, as you know, you do not need to type the multiplication sign to enter $3x$. You just write $3x$ as shown below. To graph the function you just press α (Draw).

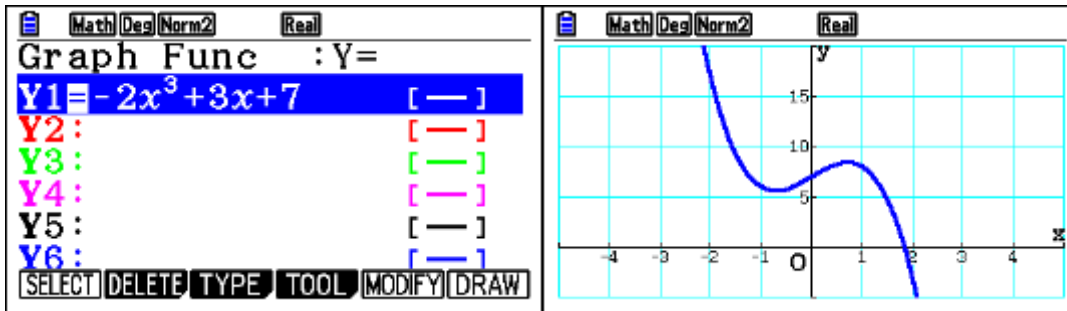

You can switch to the tabular representation of this function by going to \square then choosing $\begin{bmatrix} \text{Table} \\ \text{Table} \end{bmatrix}$ then pressing u or l

The image shows a "Table Func" window with a table of values for the function Y1. The table has two columns: X and Y1. The values are as follows:

X	Y1
1	8
2	-3
3	-38
4	-109

At the bottom right of the table is a small number "1". Below the table are several menu options: FORMULA, DELETE, ROW, EDIT, GPH-CON, and GPH-PLT.

Also, while in the **Table Func** window, press \square to set up how the table handles your data

The image shows two side-by-side windows. The left window is "Table Func : Y=" with the same function list as above. The right window is "Table Setting" and shows the following settings:

X
 Start : 5
 End : 25
 Step : 5

At the bottom of the Table Setting window are menu options: SELECT, DELETE, TYPE, STYLE, SET, and TABLE.

The image shows a "Table Func" window with a table of values for the function Y1. The table has two columns: X and Y1. The values are as follows:

X	Y1
5	-228
10	-1963
15	-6698
20	-15933

At the bottom right of the table is a small number "5". Below the table are several menu options: FORMULA, DELETE, ROW, EDIT, GPH-CON, and GPH-PLT.

Note: As you know, when exact answers are not requested, you can find solutions to many equations graphically. Some examples below and in later chapters will demonstrate this.

Equation-Solver

There are three types of tasks where the numerical solver in *fx-CG50* will do:

- Systems of linear equations - α
- Polynomial equations - w
- General equations - e

The first task is to open the **Equation** application.

In the main menu screen, scroll down to  and press 1. Alternatively press f or Lf .

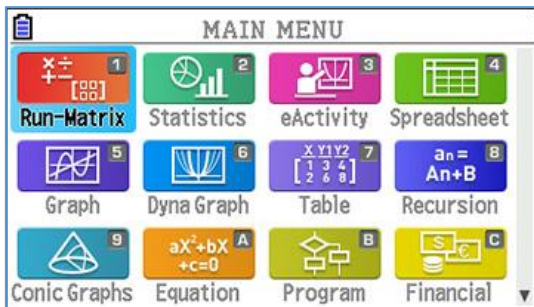

The next screen will give you a choice of the three types of operations that are possible:

1. Simultaneous: *fx-CG50* can solve systems of simultaneous equations up to 6 equations with 6 unknowns.
2. Polynomial: *fx-CG50* can solve polynomial equations up to the 6th degree.
3. Solver: *fx-CG50* can handle different types of equations that are defined by you. For example, trigonometric equations, equations involving probability distributions and many others.

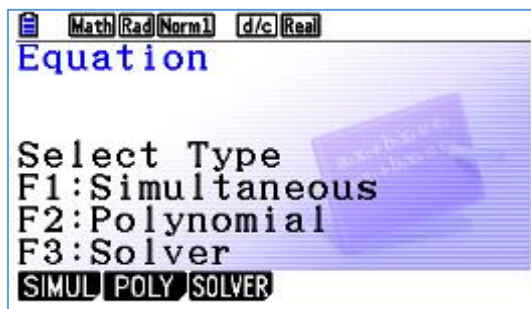

System of simultaneous equations

Example 1

Let us start with a system of equations in three unknowns. We will use the following system as an example

$$5x + y - 4z = 5$$

$$2x - 3y - 5z = 2$$

$$7x + 2y - 6z = 5$$

So, in the next screen, after pressing α , I choose w (3)

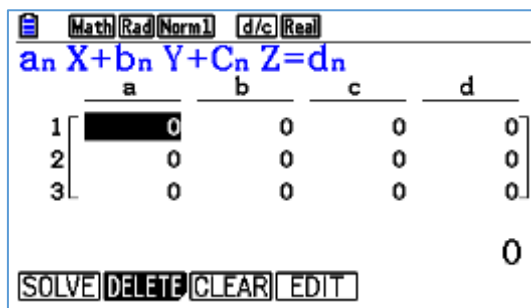
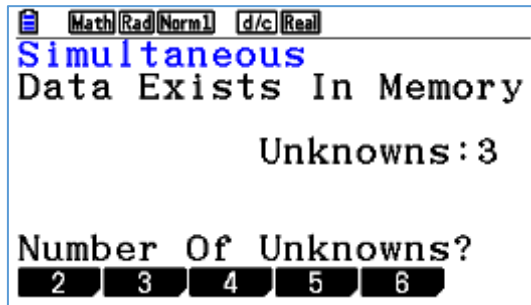

This screen shows the type of equation and the number of variables.

We edit the entries in the window to fit our system of equations. [If the gcd has been used before, you can either overwrite the numbers there, or clear the matrix entries]

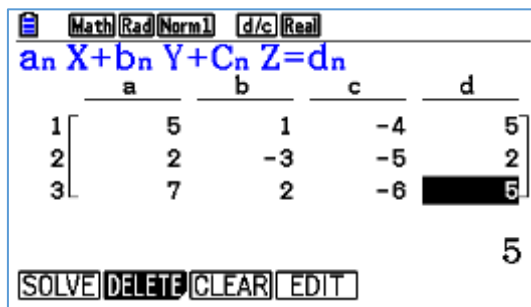

Then press 1 (you can also press α - **SOLVE**)

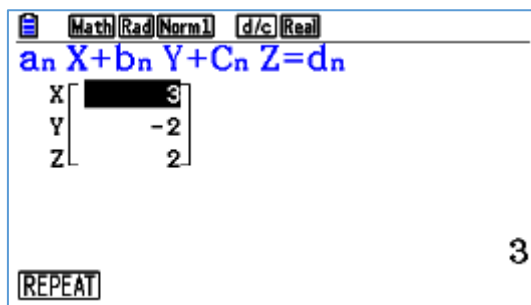

The solution is thus $\begin{bmatrix} x \\ y \\ z \end{bmatrix} = \begin{bmatrix} 3 \\ -2 \\ 2 \end{bmatrix}$

Example 2

Let us try another system

$$2x + y - z = 4$$

$$x + 3y + 7z = 7$$

$$2x + 4y + 8z = 10$$

We clear the matrix, and perform the same tasks as before

Calculator screen showing a 3x4 matrix input for a system of linear equations. The screen displays the equation form $a_n X + b_n Y + c_n Z = d_n$ and the matrix:

	a	b	c	d
1	2	1	-1	4
2	1	3	7	7
3	2	4	8	10

Buttons: SOLVE, DELETE, CLEAR, EDIT

Calculator screen showing the result "Infinitely Many Solutions" and the general solution:

Infinitely Many Solutions

$X = 1 + 2Z$

$Y = 2 - 3Z$

$Z = Z$

Button: REPEAT

The result is "infinitely Many Solutions, which is true. The calculator gives the general solution with Z as a parameter. We will discuss later, when we do Matrices, how we can also use the *fx-CG50* to get the general solution too.

Example 3

Lastly, here is another system

$$x + y + 2z = 1$$

$$x + z = 2$$

$$y + z = 0$$

We clear the matrix (you can also overwrite the numbers that are already there), and perform the same tasks as before

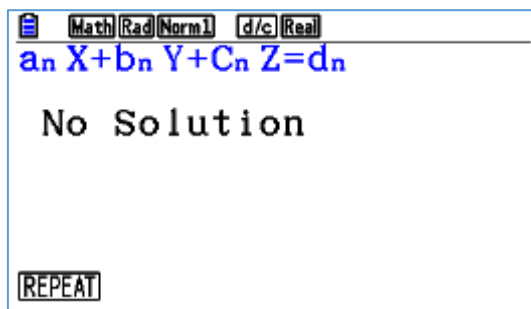
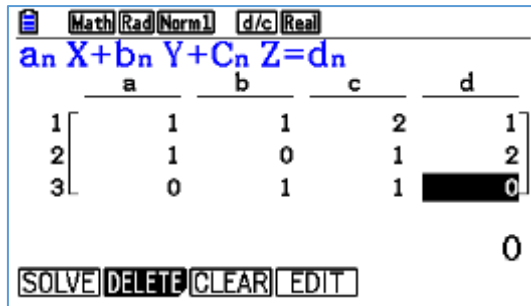

Which is also true.

Polynomial equations

The other type of equations you can use this GDC to get a numerical solution for is the polynomial equation.

Example 4

Let us take an example of a cubic equation:

$$2x^3 - x^2 - 7x + 6 = 0$$

Again, open the *Equation* application, press *w* for polynomial

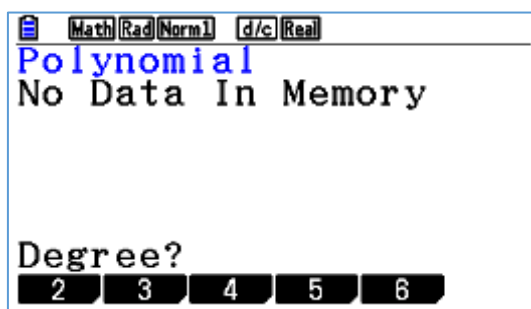

Press *w* for degree 3, and type the coefficients in

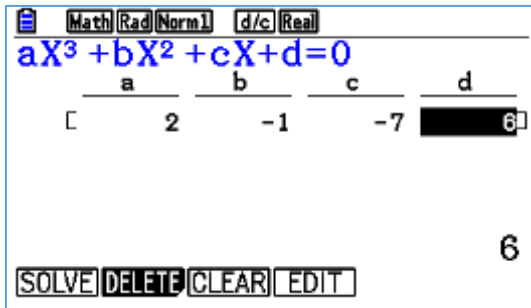

Choose \square for **SOLVE**, and here are All solutions.

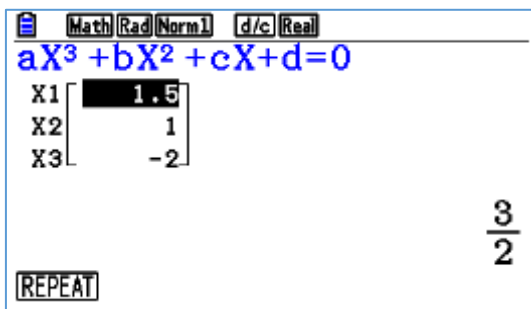

Example 5

Here is another example

$$4x^3 - 4x^2 + x - 1 = 0$$

First, press \square to **CLEAR** all entries, then type in the new coefficients,

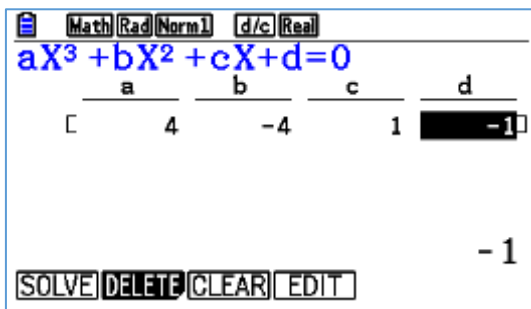

Press \square for **SOLVE**

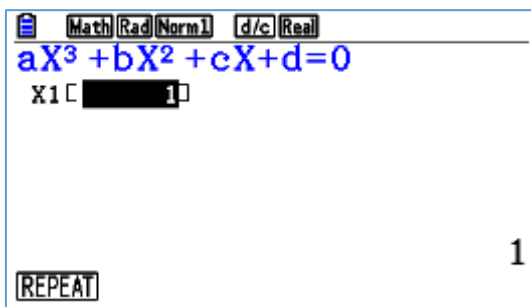

Notice here that it only gave you one real solution. This is so because the mode we left the GDC in is *Real* as you see in the top right corner of the screen.

If we need all solutions, then we need to change the mode.

We go to *SET UP*

First press `d` followed by `(L-p)` and then scroll down to Complex Mode

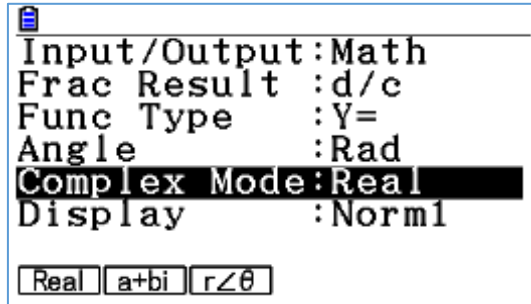

Then we change it to **a + bi** by pressing `w`

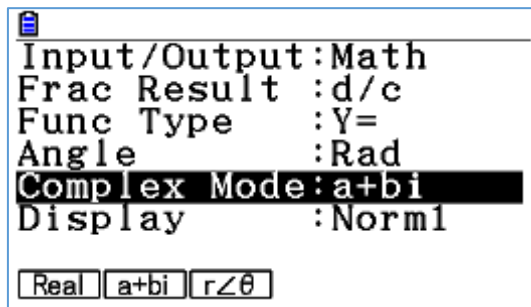

Now, we can solve the equation again and get all solutions

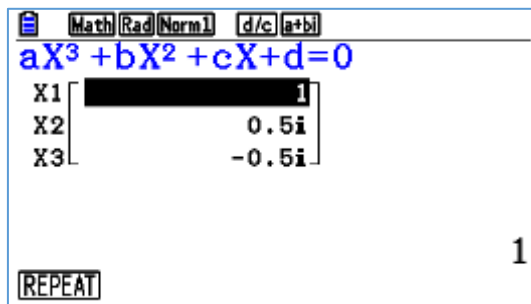

Again, let us solve the equation

$$4x^3 - 4x^2 - 3x + 3 = 0$$

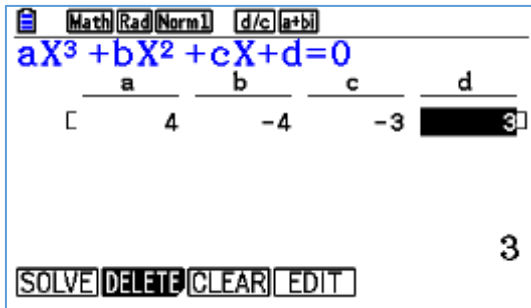

We get 3 solutions

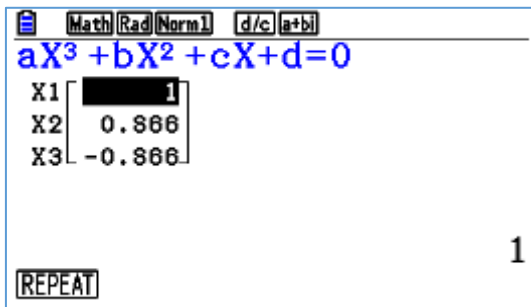

However, as you pass the cursor over the decimal answers, you can see the exact answer too.

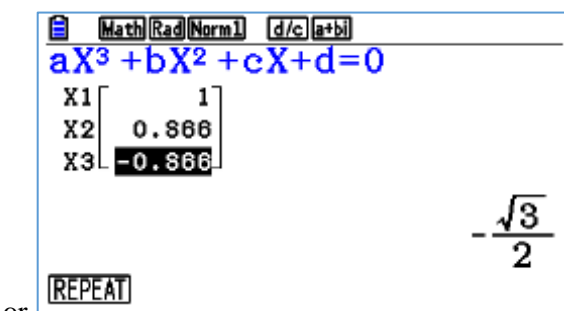
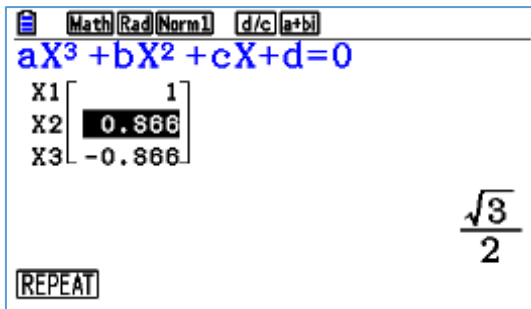

or

Example 6

And again

$$x^3 + 4x^2 + 3x + 3 = 0$$

We receive the numerical approximate result since the equation does not have a clear integer solution

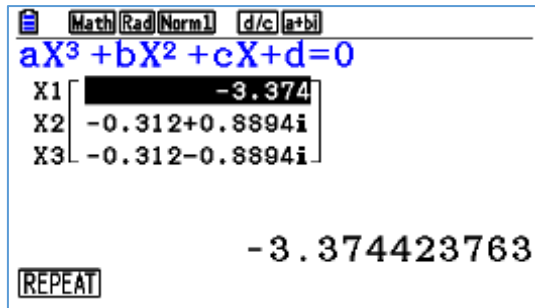

General Equations (Solver)

The GCD can also be used to solve specific equations that are defined by you.

Example 7

For example (More on this later), suppose you want to find the 90th percentile of the standard normal distribution without using the specific built in process.

Then you can define an equation which will give you the area under the Standard Normal curve between an extreme value on the left and a variable, x for example, on the right. The 90th percentile can be found if this area is equal to 0.90.

From the MAIN MENU go to  Equation

Now choose e(Solver).

Then in the Solver's window, we do one of 2 things:

1. Go to CATALOG (L4) and choose the Normal CDF function (NormCD) and fill the entries as shown, or
2. Alternatively, follow the sequence of keys: i u e q q w. (In a later chapter, we will use the Inverse Normal distribution.)

Now we have the following

```

Math Rad Norm1 d/c Real
Eq: NormCD(-10, x) = .9
    x=0.5|
Lower=-9E+99
Upper=9E+99

```

Here, we instructed the GDC to find the area under the Standard Normal curve between -10 and x and equate it to 0.9 . Then we choose any value we suspect for x to start the calculation. Leave the lower and upper limits as given by default. Press F6, and you will receive the answer to your question, i.e., $x = 1.28$.

```

Math Rad Norm1 d/c Real
Eq: NormCD(-10, x) = .9
    x=1.281551566
Lft=0.9
Rgt=0.9

REPEAT

```

Note: we can also get the result if we choose **SolveN** command as shown below. (You can reach this in CATALOGUE, or as you learned in earlier material)

```

Math Deg Norm1 d/c Real
SolveN(NormCD(-10, x)) ▶

```

JUMP DELETE MAT/VCT MATH

IB-type Exercises

Now we know how to perform the GDC operations, let us take a look at some IB-type questions and how you may attempt to answer them.

Example 8

Consider the system of equations

$$2x + 2y - 2z = -5$$

$$x + y = 1$$

$$2x + y - 2z = 3$$

Write down the solution to this system if it exists.

Exam response:

Since this is a paper 2 type of questions, it is not expected to show work.

The solution to this system is $\begin{pmatrix} x \\ y \\ z \end{pmatrix} = \begin{pmatrix} 9 \\ -8 \\ 3.5 \end{pmatrix}$

fx-CG50

We use the **Equation** application.

From the MAIN MENU, scroll to the **Equation** application as suggested previously.

Press \square for Simultaneous, w for 3 unknowns, and fill the matrix.

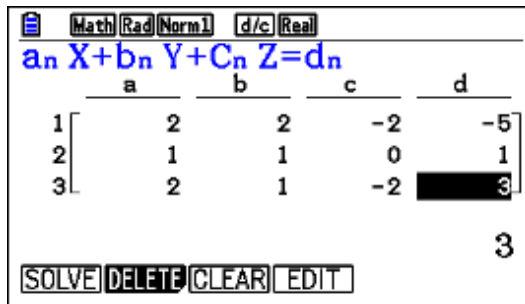

Press \square or 1 to solve.

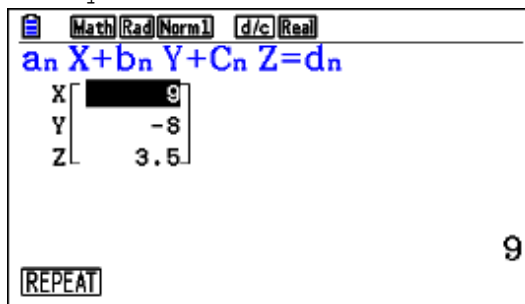

Example 9

A random variable X is normally distributed with $\mu = 50$ and $\sigma = 5$.
Find the interquartile range of X .

Exam response:

The interquartile range (IQR) is the distance between the first quartile, Q_1 and the third quartile, Q_3 .

We need to find Q_1 , Q_3 , and then subtract them. Q_1 is the number that leaves 25% of the area before it, while Q_3 leaves 75% before it.

$Q_1 = 46.63$ and $Q_3 = 53.37$, and thus the $IQR = 53.37 - 46.63 = 6.74$

fx-CG50

If we choose to use the **Solver**, then here is how we approach it. (In a later chapter, we will see another method)

We need to go to **Solver**: p, f, e, i, u, e, q, w. Now we have the following

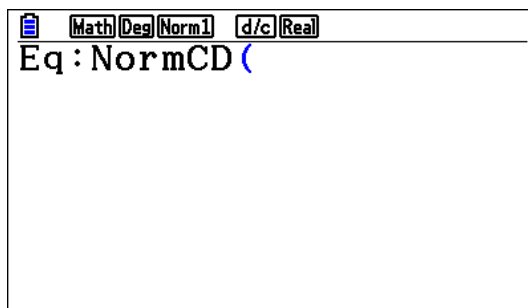

We need to type in the equation

[NormCD(lower bound, upper bound, standard deviation, mean)]

This is the cumulative area up to the upper bound which we let equal to 0.25. We let Q_1 be x and solve the resulting equation [NormCD(-200, x , 5, 50) = 0.25]:

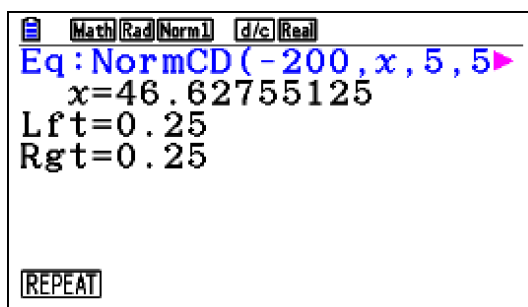

Thus $Q_1 = 46.63$

The same procedure for Q3
 [NormCD(-200, x, 5, 50) = 0.75]

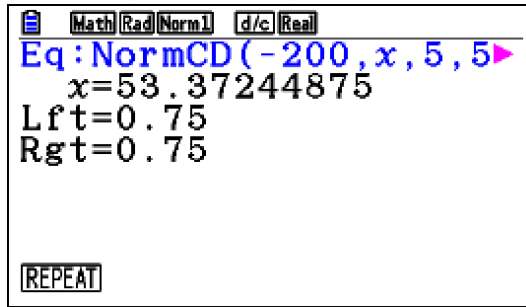

Thus $Q_3 = 53.37$

Hence the IQR = $53.37 - 46.63 = 6.74$

Note: Another approach is also possible by using the Inverse Normal distribution. We will discuss that in another chapter.

Example 10

A sketch of the graph of $f(x) = \frac{50}{1 + 25e^{-0.3x}}$ is shown below.

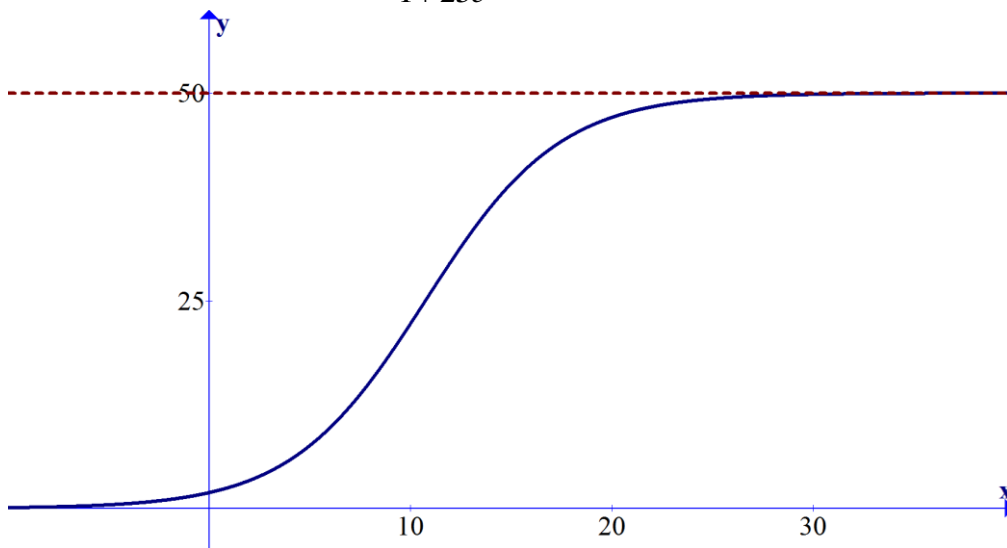

- Find the y-intercept
- Solve for $f(x) = 30$.
- Find the range of f .
- Show that $f'(x) = \frac{375e^{0.3x}}{(e^{0.3x} + 25)^2}$
- Find the maximum rate of change of f .

Exam response:

- a. The y-intercept is of the form $(0, y)$. Thus by substituting $x = 0$ into the function expression we get the y-intercept.

$$\text{Thus } y = f(0) = \frac{50}{1 + 25e^{-0.3(0)}} = \frac{25}{13} \approx 1.92$$

y-intercept: $(0, 1.92)$

b. $f(x) = 30 \Rightarrow \frac{50}{1 + 25e^{-0.3x}} = 30$

Note: since the problem says “Solve”, it is a good idea to show some work here.

$$\Rightarrow \frac{2}{3} = 25e^{-0.3x} \Rightarrow e^{-0.3x} = \frac{2}{75} \Rightarrow x \approx 12.1$$

- c. There are 2 horizontal asymptotes.

- Since $f(x) > 0$ as both the numerator and denominator cannot be negative and $\lim_{x \rightarrow -\infty} 1 + 25e^{-0.3x} = \infty \Rightarrow \lim_{x \rightarrow -\infty} \frac{50}{1 + 25e^{-0.3x}} = 0$.

- Also $\lim_{x \rightarrow \infty} 25e^{-0.3x} = 0 \Rightarrow \lim_{x \rightarrow \infty} 1 + 25e^{-0.3x} = 1 \Rightarrow \lim_{x \rightarrow \infty} \frac{50}{1 + 25e^{-0.3x}} = 50$

So, $f(x) < 50$.

Thus the range is $]0, 50[$.

- d. Here you can use the product or quotient rules. Using the quotient rule we get

$$f'(x) = \frac{-50 \times (-0.3) \times 25e^{-0.3x}}{(1 + 25e^{-0.3x})^2}, \text{ by multiplying this by } \frac{e^{0.6x}}{e^{0.6x}} \text{ we get the}$$

requested result.

- e. The maximum rate of change of the function is the maximum value of its first derivative. Thus from the graph of the derivative, the maximum is approximately 3.75.

fx-CG50

If the question in (a) were the only question using this function, it would not be efficient to use the GDC in the fashion shown here.

However, since we will need the GDC for later parts, then here is one way.

Firstly, we will have to enter the function into the GDC and use it for the rest of the question.



From the MAIN MENU, go to

Type the function in followed by 1

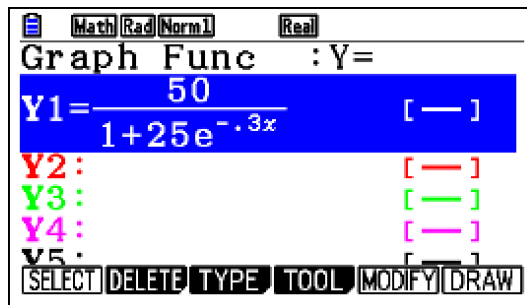

a. Go to **Run-Matrix** application (pRun-Matrix)

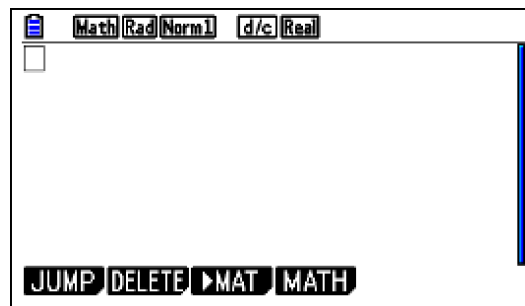

Go to \circ , choose r (GRAPH)

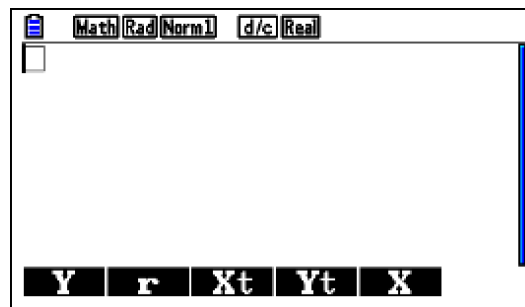

Choose $q(Y)$, and type $Y1(0)$ and press 1 to receive the answer.

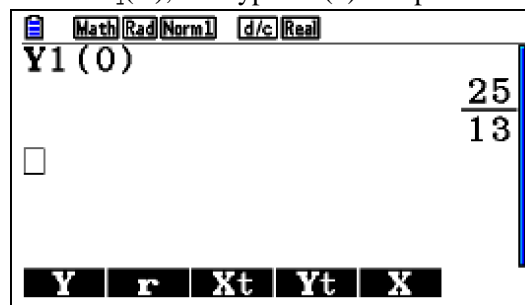

If you need the decimal value, just press n button.

- b. To solve for $f(x) = 30$, there are several ways.
 i. Use the solver

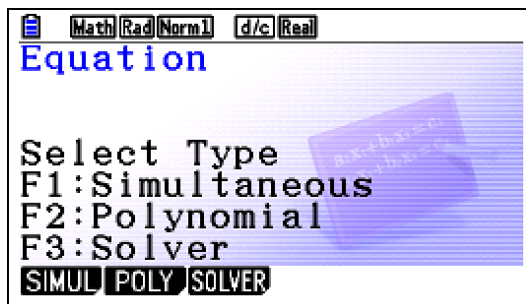

Choose *RECALL*

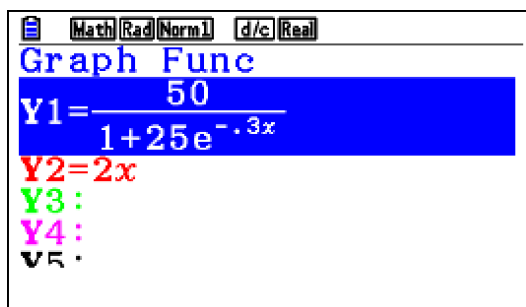

Choose Y1 and press EXE, then type = 30 and choose a value for x.

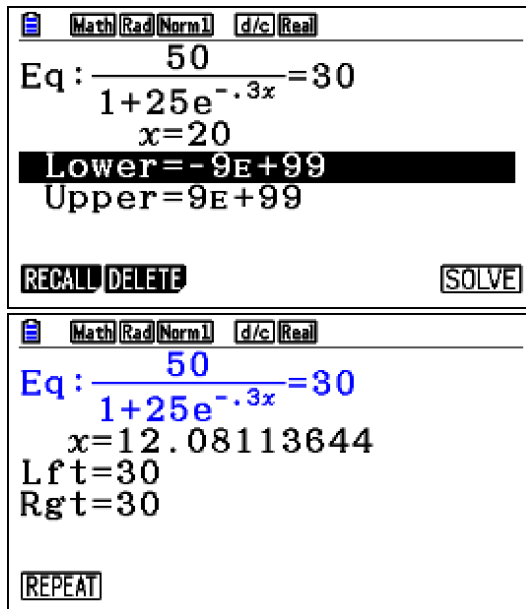

Thus the approximate solution is $x = 12.1$

- ii. Use a graphical method. Here is how.



In the Graph application, type 2 functions for $y = f(x)$ and for $y = 30$. Make sure that you select both.

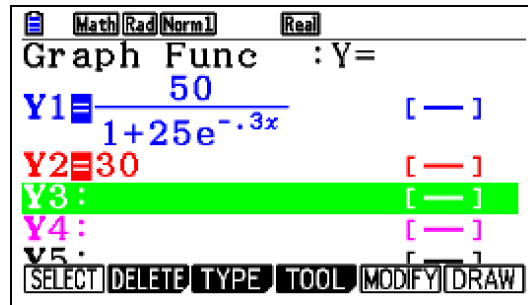

Choose \cup (DRAW)

[You can adjust the viewing window at wish: While in the **Draw** window, press Le and specify the conditions you want]

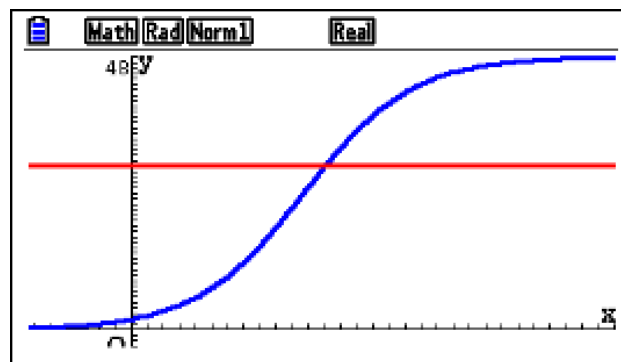

Then choose G-Solv (LY) and INTSECT (Y)

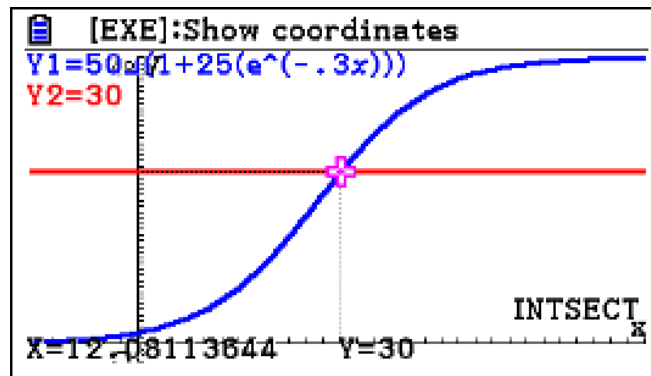

- c. To find the range, the graph will lead you to suspect that the horizontal asymptotes are $y = 0$ and $y = 50$.
To confirm the range, simply draw the line $y = 50$ and observe that the graph of the function does not go above it!
- d. This is a non-GDC question.
- e. To get the maximum rate of change, we can graph the derivative and find its maximum.
After you type in the expression for the derivative, graph it, choose G-Solv and Max

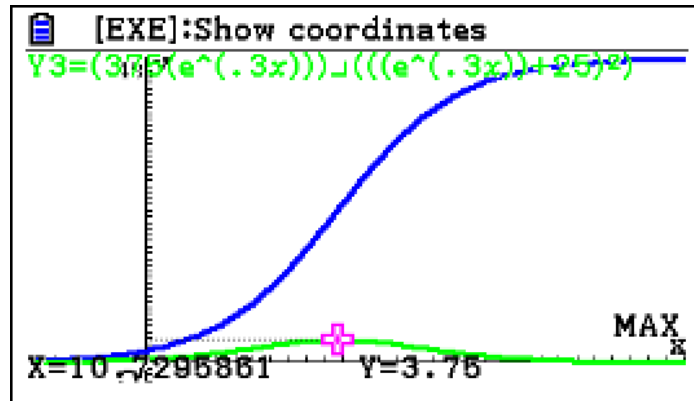

Thus the maximum rate of change is approximately 3.75.

Example 11

Consider a triangle ABC, with $\angle B = 40^\circ$, $AC = k$ m, $AB = 36$ m, and the area of the triangle is 160 m^2 . Find k , and BC.

Exam response:

The area of the triangle is given by

$$\frac{1}{2} \cdot AB \cdot BC \cdot \sin 40^\circ = \frac{1}{2} \cdot 36 \cdot BC \cdot \sin 40^\circ = 18BC \cdot \sin 40^\circ$$

Equating this area to 160 and simplifying

$$18BC \cdot \sin 40^\circ = 160 \Rightarrow BC = \frac{160}{18 \sin 40^\circ}$$

Thus $BC \approx 13.8$ m

To find k , we can use the law of cosines

$$k^2 = a^2 + c^2 - 2ac \cos B = 13.8^2 + 36^2 - 2 \times 13.8 \times 36 \times \cos 40$$

Thus $k \approx 26.9$

fx-CG50

This answer for BC can be achieved either directly in the **Run-Matrix** application

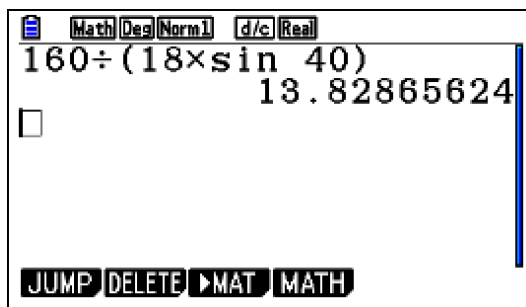

Or by using **Solve** or **SolveN** in **Run-Matrix**

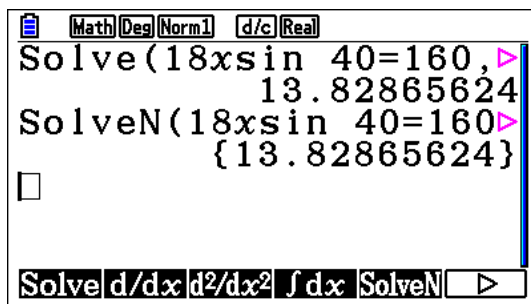

Or by using **Solver** in **Equation** application

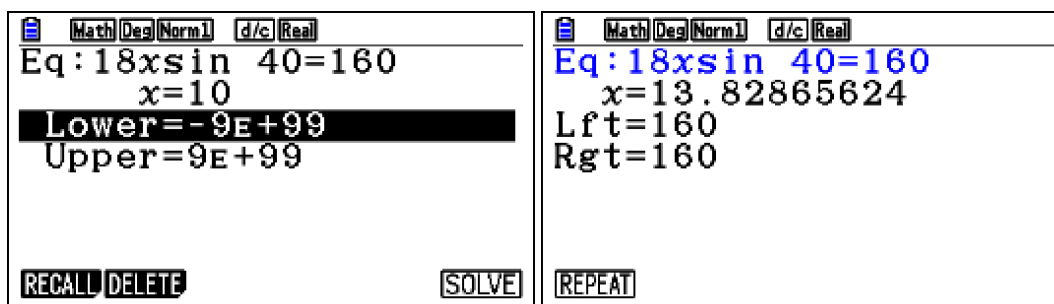

To find k , we simply apply the cosine rule (Simply type it in as shown)
Thus $k = 26.9$

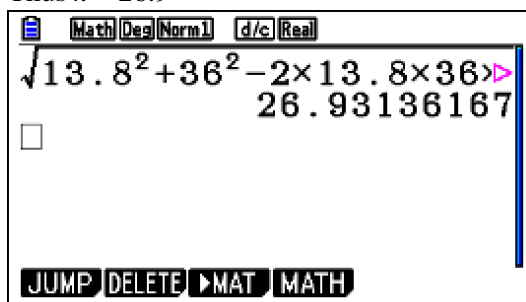

Example 12

Two points A and B lie on a circle, center O and radius r as shown in the diagram below. AC is perpendicular to OB and measure of central angle O is 1.2 radians. The area of the shaded region is 20 m^2 . Find the value of r .

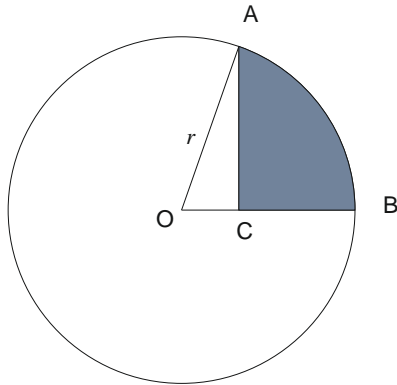

Exam response:

One way is to look at the shaded area as the difference between the area of sector OAB of the circle and the area of $\triangle OAC$.

$$\text{Area of sector} = \frac{1}{2} r^2 \theta = \frac{1}{2} r^2 \times 1.2 = 0.6r^2$$

$$\text{area of } \triangle OAC = \frac{1}{2} \times \text{base} \times \text{height} = \frac{1}{2} \times r \cos 1.2 \times r \sin 1.2 = \frac{1}{2} r^2 \cos 1.2 \times \sin 1.2$$

$$\text{Shaded area} = 0.6r^2 - \frac{1}{2} r^2 \cos 1.2 \times \sin 1.2 = 20$$

Thus $r = 6.81 \text{ m}$.

Alternatively, another way is to reflect the upper part over OB as shown below

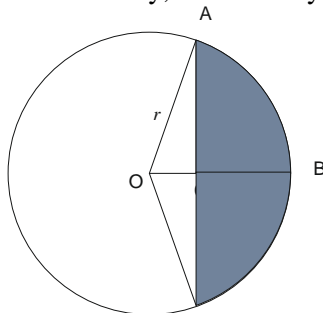

The original shaded region is half the one in this diagram,

$$\text{Area of shaded region} = \frac{1}{2} \left(\frac{1}{2} r^2 \theta - \frac{1}{2} r^2 \sin \theta \right) = 20 \text{ with } \theta = 2 \times 1.2 = 2.4 \text{ radians}$$

That is: $\frac{1}{2} \left(\frac{1}{2} r^2 \times 2.4 - \frac{1}{2} r^2 \sin 2.4 \right) = 20$

fx-CG50

We can use **SolveN** for this (“ screen shots just to show the whole expression)

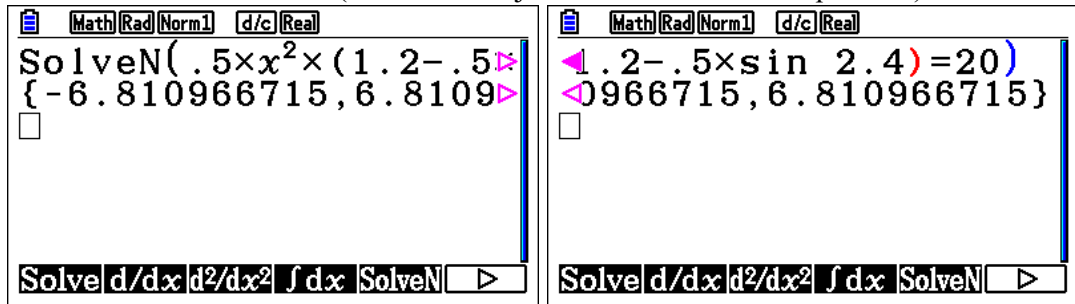

Alternatively, putting this expression into Solver will give the same result.

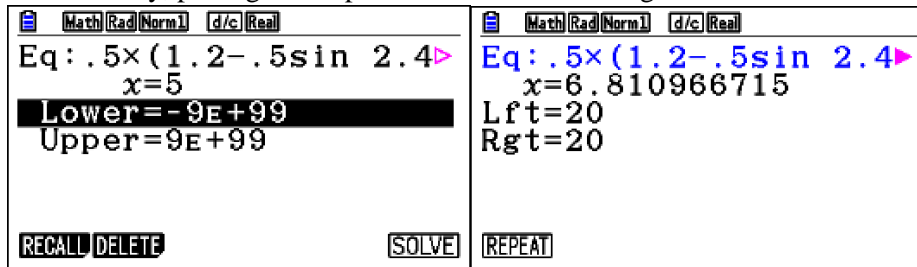

Example 13

Solve the equation $3 \sin^2 x + 8 \cos x - 7 = 0$, where $0^\circ \leq x \leq 180^\circ$, and express your answer(s) to the nearest degree.

Exam response:

One way is to replace $\sin^2 x$ by $1 - \cos^2 x$ to get a quadratic equation in $\cos x$

$$3 \sin^2 x + 8 \cos x - 7 = 3(1 - \cos^2 x) + 8 \cos x - 7 = -3 \cos^2 x + 8 \cos x - 4 = 0,$$

Thus Thus $x = 48^\circ$.

fx-CG50

We can use **SolveN** for this (“2 screen shots just to show the whole expression”) Make sure that the mode is in degrees, and specify a range for the solution.

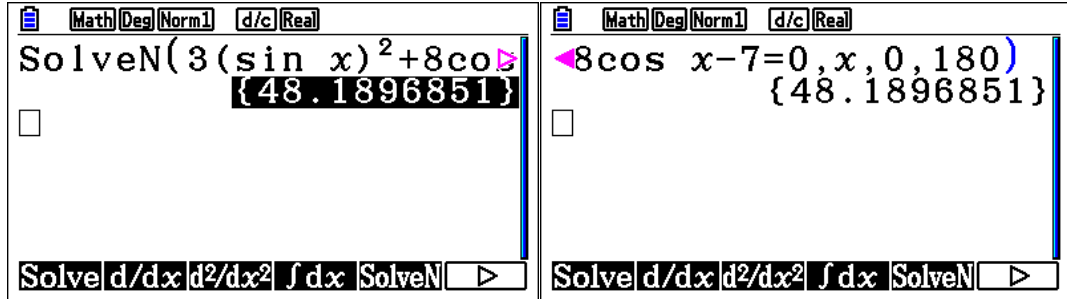

Solver can also be used. Make sure that you type a minimum of 0 for the values.

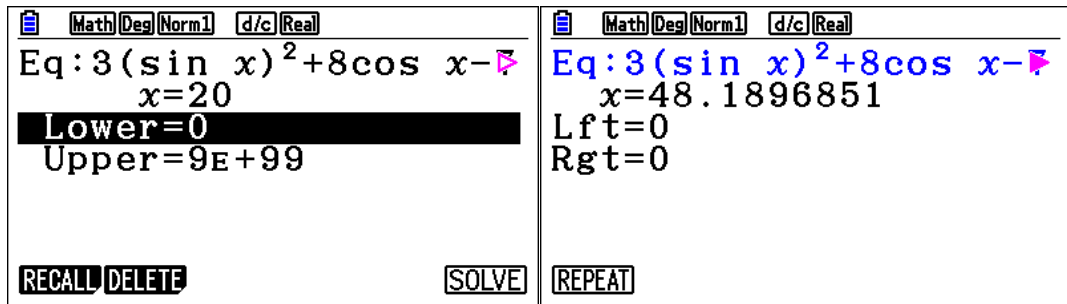

Example 14

For what values of x is the following inequation true?

$$-7x^2 - 27x + 4 \geq 0$$

Exam response:

Since this is a paper 2 question, one way is to show a sketch of the graph of the function $f(x) = -7x^2 - 27x + 4$ and identify the part corresponding to the part above the x -axis (including the zeros in this case).

Thus the solution to $-7x^2 - 27x + 4 \geq 0$ are all values of x such that

$$x \in [-4, 0.143] = \left[-4, \frac{1}{7}\right]$$

Another way, using the hint you get from the graph that $x = -4$ is an x -intercept, is that you factor the polynomial

$$(x + 4)(-7x - 1)$$

Then using the “test-point” method, you test a point within that interval, 0 for example, and “find out” that the polynomial $f(x) = -7x^2 - 27x + 4 > 0$.

There are some other methods too.

fx-CG50

In order for you to draw your conclusions above, you will need to graph the function $f(x) = -7x^2 - 27x + 4$ first. (Function graphing will be dealt with later in the booklet)



Press \square and scroll down to Graph application.

Type the equation into a free slot and press \square

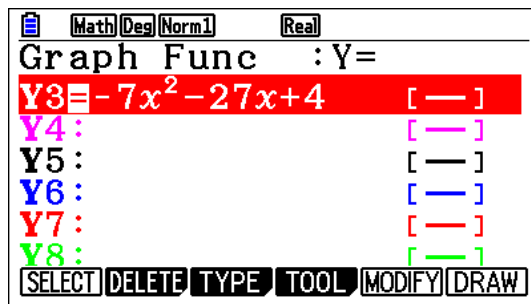

Now press \square to plot the graph. (If the viewing window is not appropriate for the graph, you can change the settings by pressing \square)

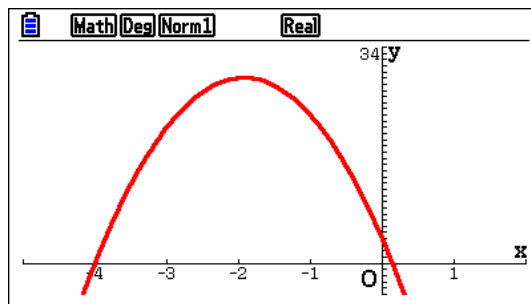

Now press \square this gives you the first x -intercept: $x = -4$

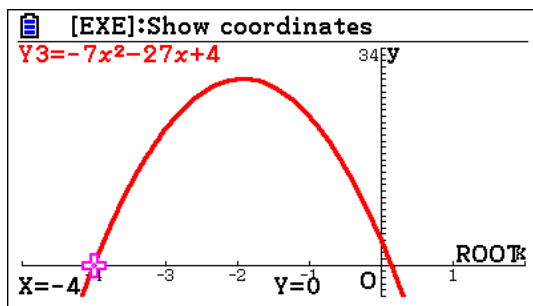

Press $\$$ and this gives you the second x – intercept: $x = 0.1429$

(To get the exact intercept you can use **SolveN**)

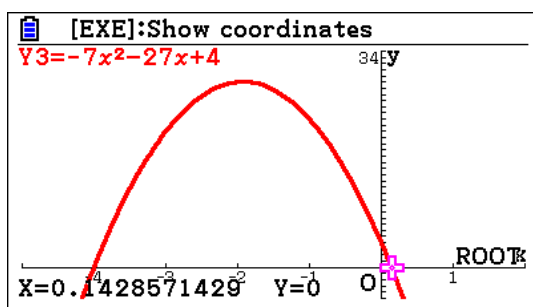

If you need a confirmation of your solution, then do the following:

First, In **SET UP**, make sure you chose **Ineq Type** to *Intersect* (See next chapter)

Now, on the **Graph Func** window, Press ϵ (TYPE), then γ (CONVERT), then $\cup\cup\epsilon$ (to shade the region below $f(x)$).

Also for enter a new function, $y = 0$, then press ϵ (TYPE), then γ (CONVERT), then $\cup\cup\omega$ (to shade the region above the line).

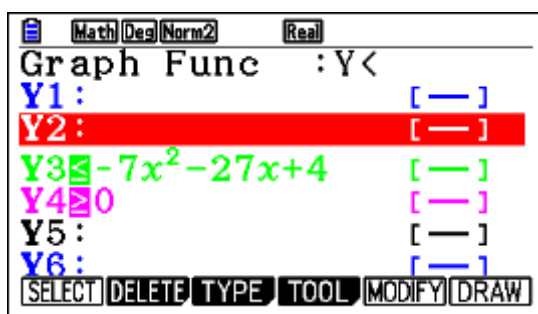

Press \cup to draw.

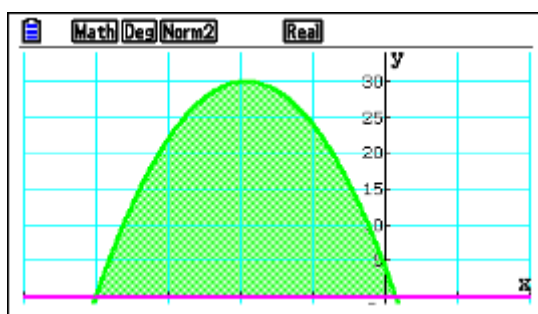

Alternatively, in **Graph Func** Window, Press $\text{OR}\square 3$ (or any other number corresponding to the function) $\text{L}7$ (Catalogue), scroll down to $\geq, 0 \text{ l u}$

This is a representation of the “logic” equation which gives 1 if the statement is true, or 0 if the statement is false. As you notice here, the graph is $y = 1$ over the interval

$\left[-4, \frac{1}{7}\right]$ and $y = 0$ for all values outside this interval.

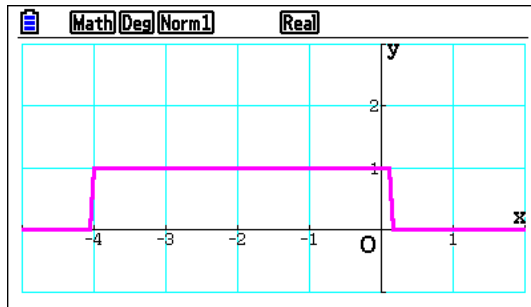

Example 15

Solve the following inequation

$$\frac{|x-1|+3}{|x+1|-2} < 2$$

Exam response:

Also in this case, since this is a paper 2 question, one way is to show a sketch of the graph of the function $f(x) = \frac{|x-1|+3}{|x+1|-2}$ and identify the part corresponding to the part below the

graph of the function $y = 2$. (or alternatively sketch of the graph of the function

$f(x) = \frac{|x-1|+3}{|x+1|-2} - 2$ and identify the part corresponding to the part below the x - axis.

We will use this function in the gdc solution.)

We need to observe that the function has two vertical asymptotes at $x = -3$ and $x = 1$ so that we remove them from the solution set.

Thus the solution to $\frac{|x-1|+3}{|x+1|-2} < 2$ are all values of x such that

$$x \in]-\infty, -10[\cup]-3, 1[\cup]4, \infty[$$

fx-CG50

In order for you to draw your conclusions above, you will need to graph the function

$$f(x) = \frac{|x-1|+3}{|x+1|-2} - 2$$



Press \square and scroll down to **Graph** application.

Type the equation into a free slot and press \square

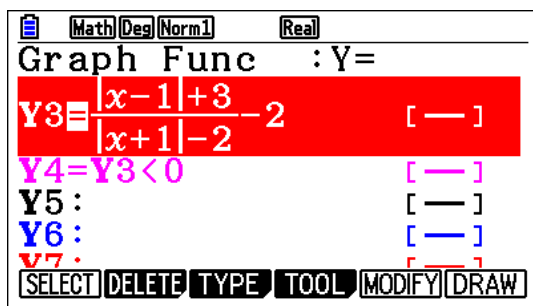

Now press \square to plot the graph. (If the viewing window is not appropriate for the graph, you can change the settings by pressing \square)

Now press \square this gives you the first x -intercept: $x = -10$

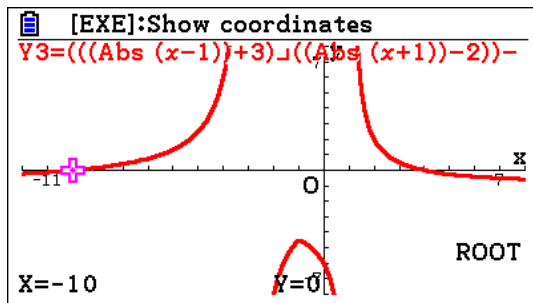

Press \square and this gives you the second x - intercept: $x = 4$

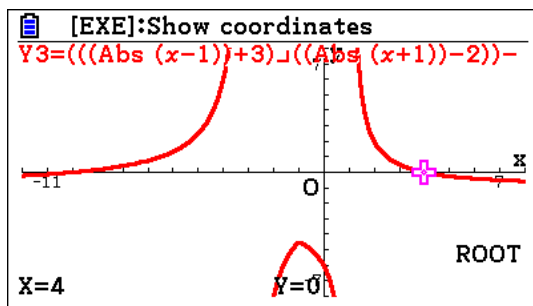

Alternatively, on the **Graph Func** window, go to each of the functions and do the following

Press \square (TYPE), then \square (CONVERT), then \square (to shade the region above $f(x)$).

Also create $y = 2$, ϵ (TYPE), then y (CONVERT), then \llcorner (to shade the region below the line).

Press \cup to draw. \llcorner

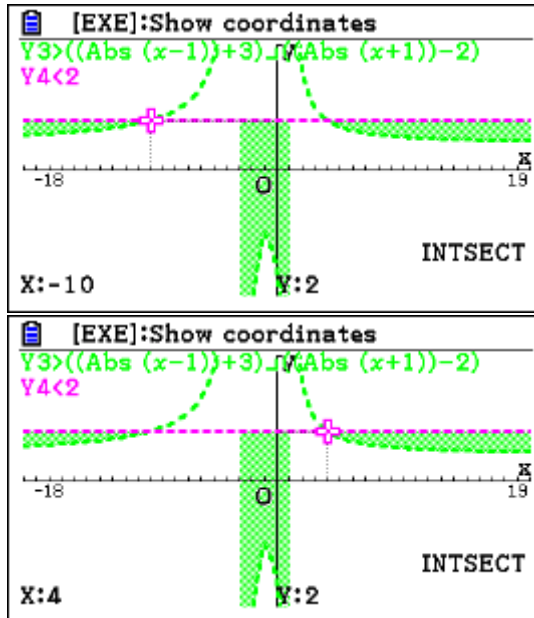

Or, in **Graph** Window, Press \circ r \circ 3 (or any other number corresponding to the function) \llcorner 7(Catalogue), scroll down to \llcorner , \circ 1 \cup

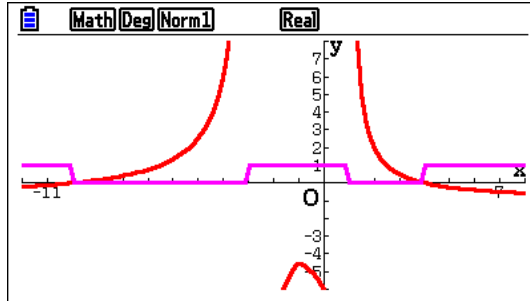

Example 16

Consider $p(x) = 3x^3 - kx + 3k$, $k \in \mathbb{R}$.

The polynomial $p(x)$ leaves a remainder of -7 when divided by $(x - k)$.

Show that only one value of k satisfies the above condition and state its value.

Exam response:

Using the Remainder theorem, $p(x)$ leaves a remainder of -7 when divided by $(x - k)$ if

$$p(k) = -7$$

$$\text{Hence } p(k) = 3k^3 - k^2 + 3k = -7 \Rightarrow 3k^3 - k^2 + 3k + 7 = 0$$

By inspection $k = -1$, is a solution, and by also by inspection we factor the polynomial

$$3k^3 - k^2 + 3k + 7 = (k + 1)(3k^2 - 4k + 7)$$

The first factor corresponds to the value of $k = -1$ while the second factor does not have a real solution because its discriminant of -68 is negative.

fx-CG50

This is simply finding solution(s) to the equation $3k^3 - k^2 + 3k = -7$.

In **Run-Matrix** application:

input, type in the equation, 1

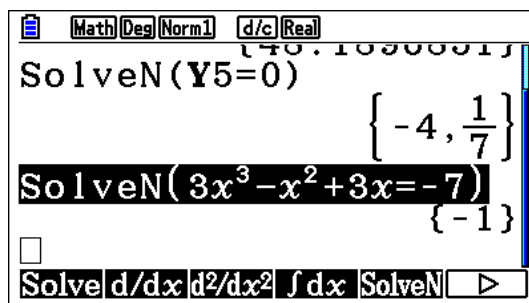

This gives one real solution but does not help with its uniqueness.

To get all real and complex solutions we need to go to the **Equation** application.

First we change the mode to complex, LpNNw.

Now p and scroll down to **Equation**, 1

ww, type the coefficients followed by 1, then q for **SOLVE**

Math Rad Norm1 d/c a+bi

$aX^3 + bX^2 + cX + d = 0$

X1 [-1]

X2 [0.6666+1.3743i]

X3 [0.6666-1.3743i]

REPEAT

- 1

Math Rad Norm1 d/c a+bi

$aX^3 + bX^2 + cX + d = 0$

X1 [-1]

X2 [0.6666+1.3743i]

X3 [0.6666-1.3743i]

$\frac{2 + \sqrt{17}i}{3}$

REPEAT

Example 17

Consider the points A(4, 3, 2), B(5, 6, 4), and C(6, 7, $k + 2$), with $k \in \mathbb{R}$.

- a. Find \overrightarrow{AB} and \overrightarrow{AC} .

Let α be the angle between \overrightarrow{AB} and \overrightarrow{AC} .

- b. Find the value of k so that $\alpha = \frac{\pi}{2}$.
- c. Find the value of k so that $\alpha = 68^\circ$.

Exam response:

- a. This is a non-gdc part:

$$\overrightarrow{AB} = \begin{pmatrix} 5-4 \\ 6-3 \\ 4-2 \end{pmatrix} = \begin{pmatrix} 1 \\ 3 \\ 2 \end{pmatrix}; \overrightarrow{AC} = \begin{pmatrix} 6-4 \\ 7-3 \\ k+2-2 \end{pmatrix} = \begin{pmatrix} 2 \\ 4 \\ k \end{pmatrix}$$

- b. If $\alpha = \frac{\pi}{2}$, then the scalar product must be zero

$$\overrightarrow{AB} \cdot \overrightarrow{AC} = 0.$$

$$14 + 2k = 0, \text{ Thus } k = -7$$

- c. For α to be 68° , then $\cos \alpha = \cos 68^\circ$,

$$\text{but, } \cos \alpha = \frac{\overrightarrow{AB} \cdot \overrightarrow{AC}}{|\overrightarrow{AB}| \cdot |\overrightarrow{AC}|},$$

$$\text{and so } \frac{\overrightarrow{AB} \cdot \overrightarrow{AC}}{|\overrightarrow{AB}| \cdot |\overrightarrow{AC}|} = \frac{14 + 2k}{\sqrt{14} \times \sqrt{20 + k^2}} = \cos 68^\circ$$

$$\text{Thus } k \approx -3.162$$

fx-CG50

- a. non-gdc
- b. not efficient with gcd.
- c. we may either go to **SolveN**

try and type the equation $\frac{14+2k}{\sqrt{14} \times \sqrt{20+k^2}} = \cos 68^\circ$

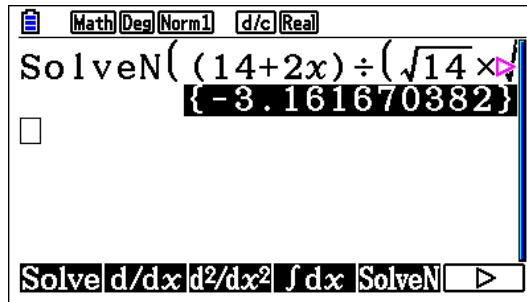

Or, we go to **Solver** in the **Equation** application

press **1**, Type the equation, **N**, put a value for x (0 for example),

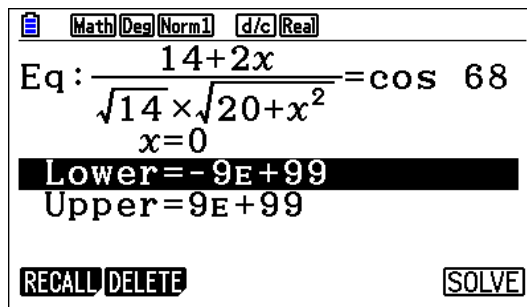

and then **u** to solve

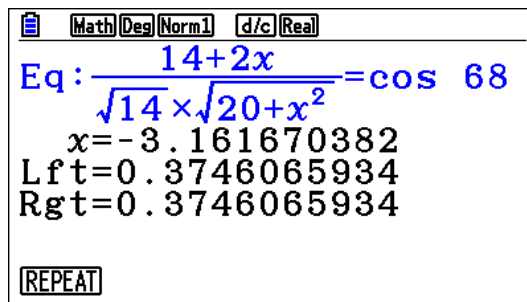

Example 18

An arithmetic sequence is given by 7, 10, 13, ...

- Find the 100th term, u_{100} .
- Find the 100th partial sum, S_{100} .
- Given that $u_n = 1210$, find the value of n .

Exam response:

- $u_n = u_1 + (n-1)d$. As $d = 3$, then $u_{100} = 304$.
- Since we know the 100th term, then we use the formula $S_n = \frac{n}{2}(u_1 + u_n)$ for S_n .

Thus $S_{100} = 15550$

Alternatively, you can use the explicit definition: $S_n = \frac{n}{2}(2u_1 + (n-1)d)$

- Since $u_n = u_1 + (n-1)d$, then $1210 = 7 + (n-1)3$ and hence $n = 402$.

fx-CG50

- The GCD uses a_n rather than u_n .

From the main menu go to **Recursion**.

Note: In order to see the partial sum of a sequence, we need to enable this feature first. While in **Recursion**, go to **SET UP** (LpNq)

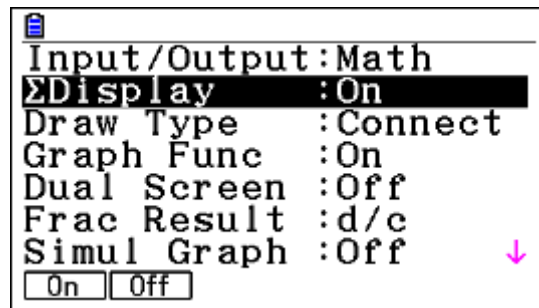

Press \square to go to the **Recursion** window again.

We can use either use the explicit or recursive definition.

i. Explicit

Press eq

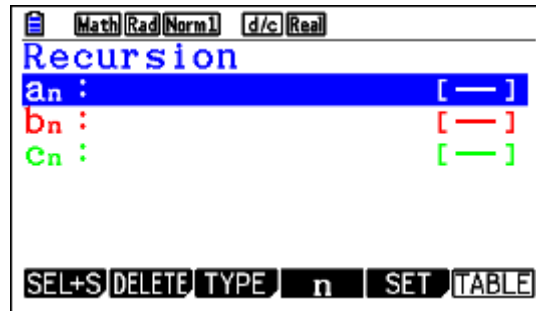

(Note the change in the menu at the bottom of screen)

r , type the expression $7 + 3(n - 1)$, y , enter 100 for **Start** and **End**

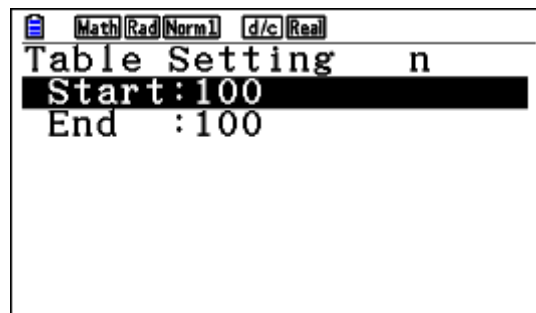

Now press Lu

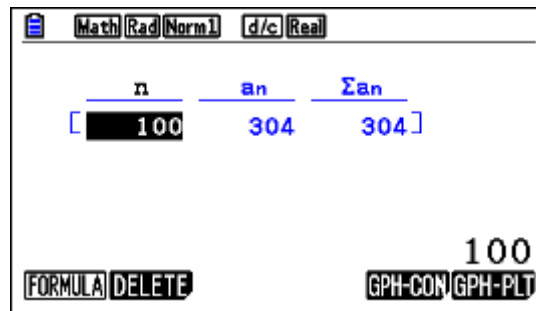

Note: in this mode, the sum is the sum of terms you entered. That is, here it is only the 100th term. If you want the sum of the first 100 terms, then in the **SET** command you need to start with 1.

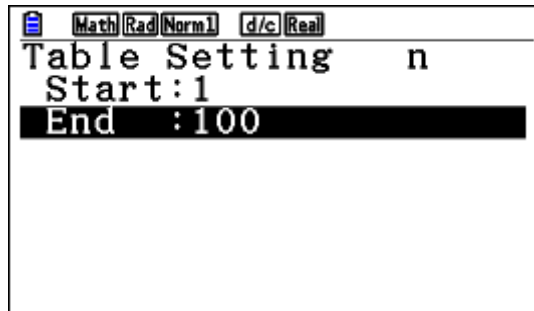

When you press \square you will be given the whole table and you have to scroll down to the 100 to see the required sum

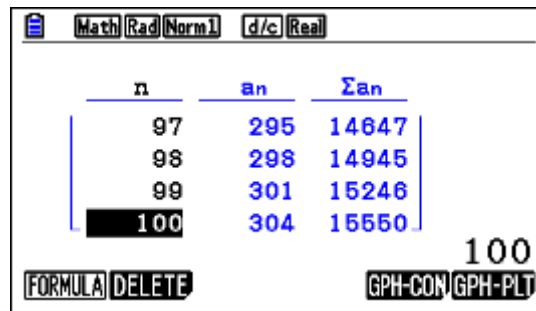

ii. Recursive

Press \square

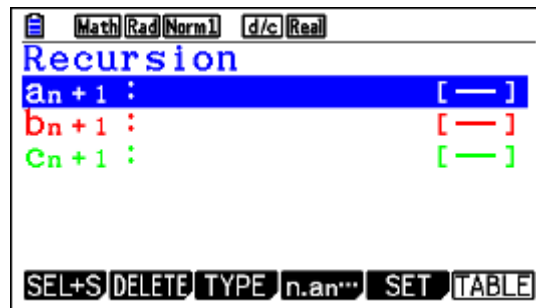

Press \square , type the expression $a_n + 3 (w+3)1$, y , enter 100 for **Start** and **End**, choose $w(a_1)$ and enter 7

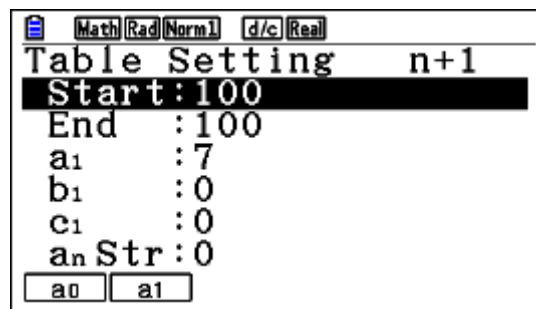

Press \square

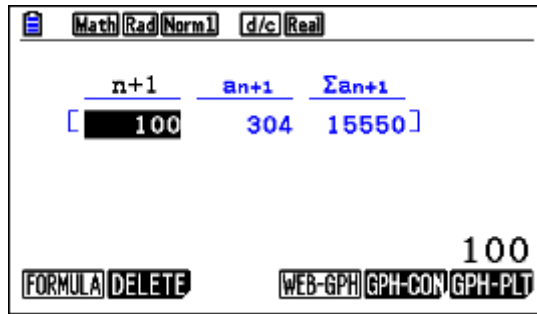

b. Already done above.

c. In **Run-Matrix** app.

Press i y , Then type in the equation as shown, 1

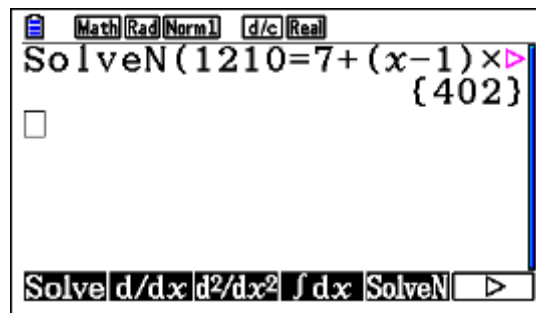

Example 19

Find all values of x that satisfy the inequality $\frac{2x}{|x-1|} < 1$

Exam response:

Using the graph of $f(x) = \frac{2x}{|x-1|}$ and $y = 1$, we see that they intersect at $x = \frac{1}{3}$ and that

$f(x) < 1$ for all values of x smaller than $\frac{1}{3}$. Thus the solution is $\left] -\infty, \frac{1}{3} \right[$.

fx-CG50

From the **Run-Matrix** app.

Press $\text{iry2fMiurqf-1}\$L.1)1$

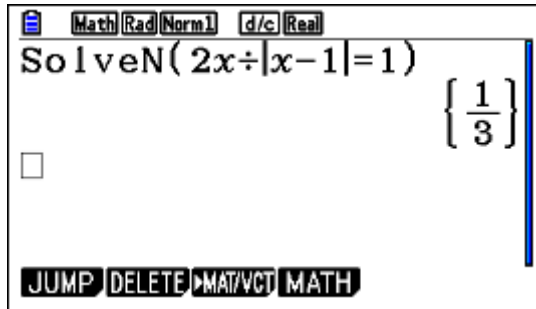

Now use the *test-point method* and replace x with a value less than $\frac{1}{3}$ (0 for example).

Alternatively, on the **Graph Func** window, go to the function and do the following

Press e (TYPE), then y (CONVERT), then uuw (to shade the region above $f(x)$).

Also create $y = 1$, e (TYPE), then y (CONVERT), then uue (to shade the region below the line).

Press u to draw, then yy

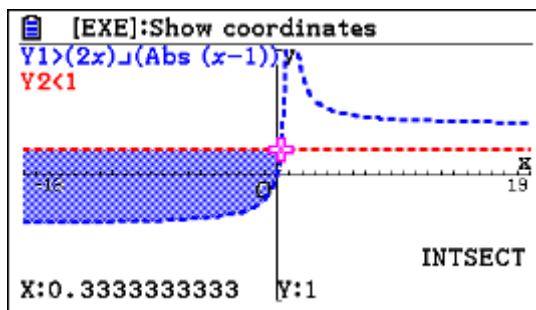

Example 20

A sum of \$5000 is invested at a compound interest rate of 6.3% per annum.

- Write down an expression for the value of the investment after n full years.
- What will be the value of the investment at the end of five years?
- The value of the investment will exceed \$10 000 after n full years.
 - Write an inequality to represent this information.
 - Calculate the minimum value of n .

Exam response:

- a) $A(n) = 5000(1 + 0.063)^n$
- b) $A(5) = 5000(1 + 0.063)^5 = 6786.35$
- c) (i) $5000(1 + 0.063)^n \geq 10000$
- (ii) $(1 + 0.063)^n \geq 2 \Rightarrow n \geq 11.3$ and so the minimum value is 12 years.

fx-CG50

- a) non-gdc
- b) Go to **Financial** app.

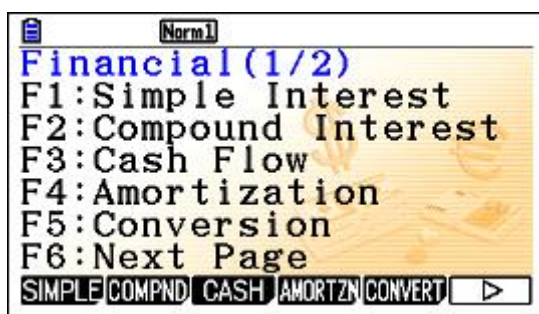

Press w, replace the numbers as shown

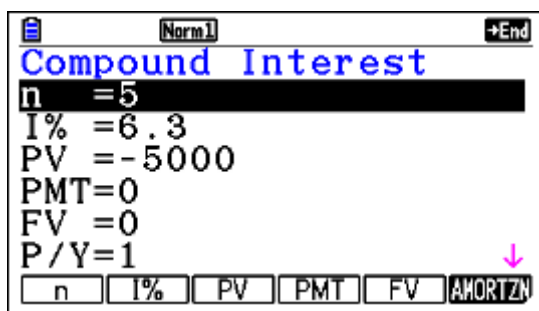

Note: the principal is entered as a negative number.

Now press y

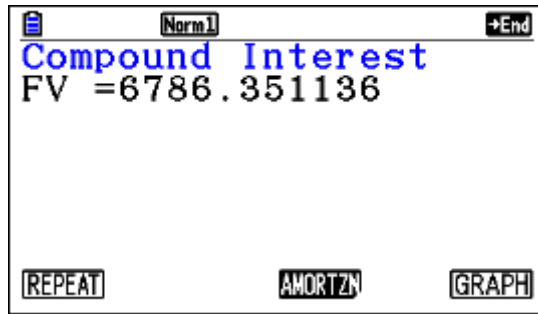

- c) Go to **Run-Natrix** app
 Press $\text{iry}1.063^{\wedge}\text{f}\$L.2)1$

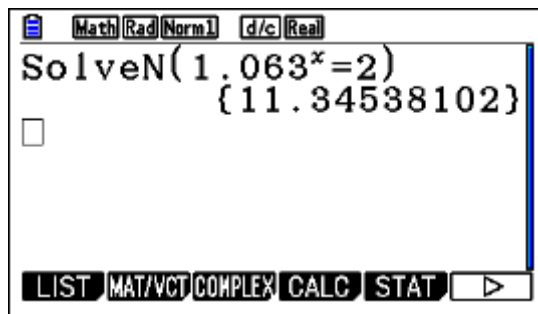

Example 21

Solve the equation $e^{-x} - x + 1 = 0$

Exam response:

This can be written as $e^{-x} = x - 1$ and the solution would be the intersection between $f(x) = e^{-x}$ which is strictly decreasing and $g(x) = x - 1$ which is strictly increasing. There is one solution $x = 1.28$.

fx-CG50

Go to **Run-Natrix** app.

Press iry , enter the equation and press 1

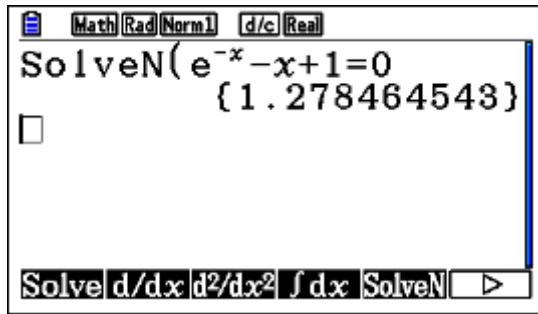

Example 22

$$\text{Solve } \left| e^{2x} - \frac{1}{x+2} \right| = 2$$

Exam response:

This can be done numerically since it is a combination of a transcendental function with a rational function. The solution is the intersection between $y = \left| e^{2x} - \frac{1}{x+2} \right|$ and $y = 2$.

Thus the solution set is $\{-2.50, -1.51, 0.440\}$

fx-CG50

Again this can be done with **SolveN**. It can also be done with **Solver**.

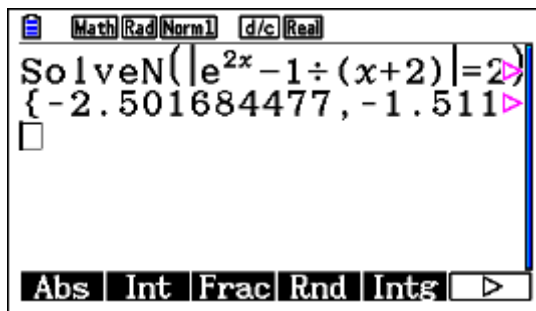

Chapter 3 Calculus

This chapter will discuss exercises and problems related to calculus topics including functions, function transformations, inverse functions, rational and Logarithmic and exponential functions. Also it will include problems relating to differential and integral calculus.

Graphing

It is important to remember that you need to choose an appropriate window in order to have the correct view of your graph. This is where your mathematics along with a good knowledge of what the calculator does helps. The basic principle is that, when you zoom out, you get an idea of the general shape of the graph, but if you want a detailed investigation, then you need to zoom in.

A GDC displays a rectangular portion of the graph of a function in a viewing screen or window. The default screen for fx -CG50 is $[-10, 10]$ for both x and y variables.

How do we change the window dimensions?

- From the main menu screen

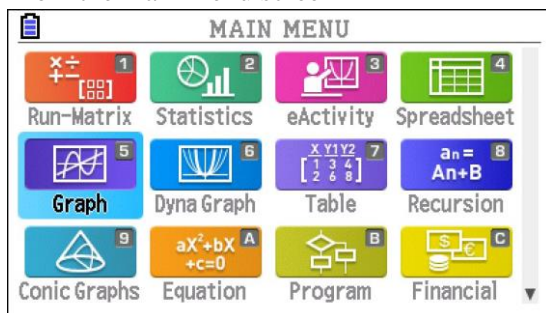

Choose  and press 1

- Now press \square (V-Window – Viewing window), then change the settings as you wish.

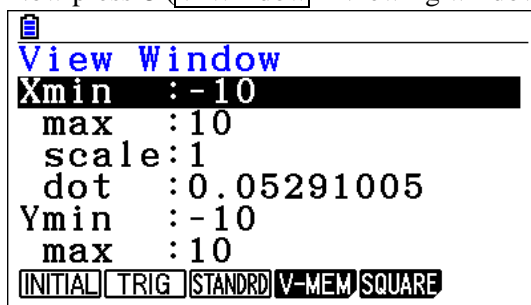

- Alternatively, from most apps, just press $\text{L}\square$ will lead you to the same menu.

Example

Consider the function $f(x) = \cos x - \frac{\sqrt{x}}{10}$.

Let us graph this function with the standard window $[-10,10]$ by $[-10,10]$.

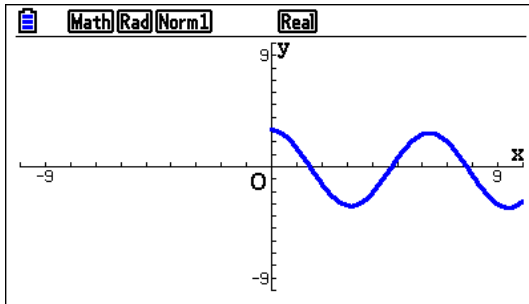

It appears like a normal cosine function drawn for positive values of x .

Note: that, in order not to get surprises, you should have the angle in radians! Otherwise, here is what you get

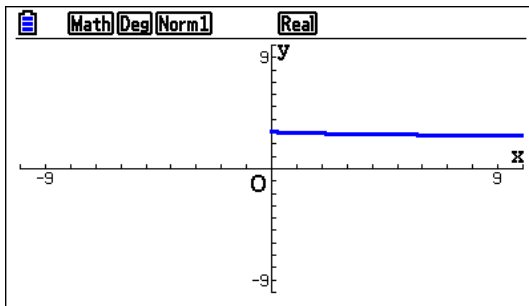

If we specify another window such as $[0, 200]$ by $[-6, 5]$, we get the general shape of the graph

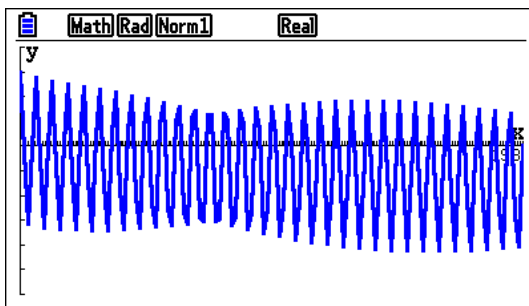

While if we are interested in confirming that this is not a periodic function we can zoom on part of it and look for more details (We can tell that it is not periodic since the values of $\frac{\sqrt{x}}{10}$ increase as x increases)

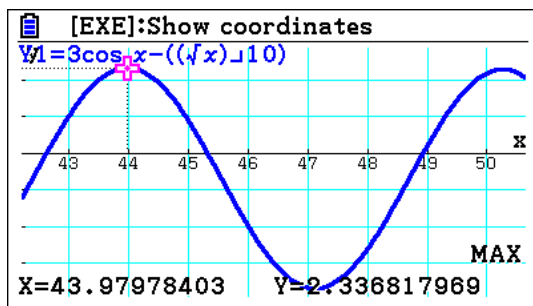

In this screen, we used zoom/Box option and focused on two peaks. Here is how

- While in graph window, press \square , then \square (BOX)

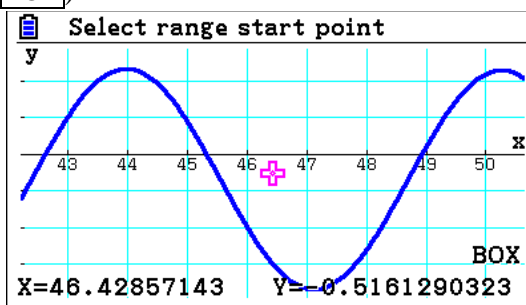
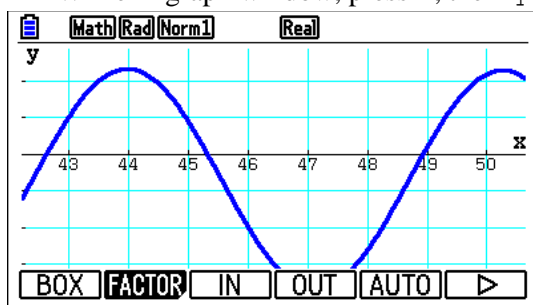

- This will give you a window with the cursor floating in the middle. With the arrows, move the cursor to one of the corners (Top-left here), and press \square , then move the cursor to the diagonally opposite corner (bottom-left here) and press \square . This will draw the graph in the desired window.
- Now, press \square and \square (MAX), which will give you the first maximum value of 2.3368. If you press the right arrow, it will give you the second maximum of 2.291. Since they are different, it may not be a periodic function.

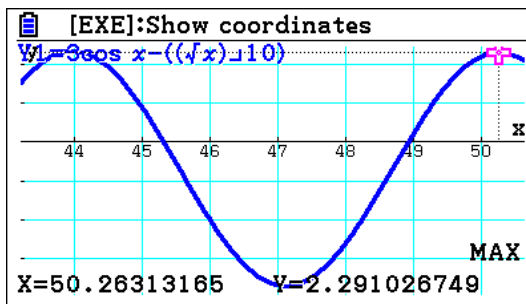
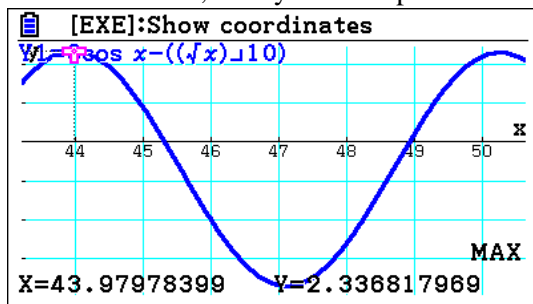



Calculus concepts

Before getting started with calculations involving derivatives, it's helpful to enable the display of the value of the derivative (dy/dx).

Enabling display of the value of the derivative dy/dx

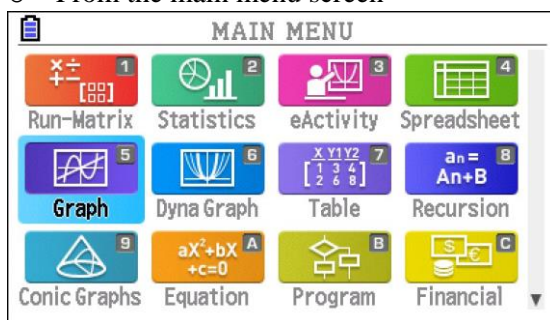
- From the main menu screen



Choose  and press 1

- From the graphing app

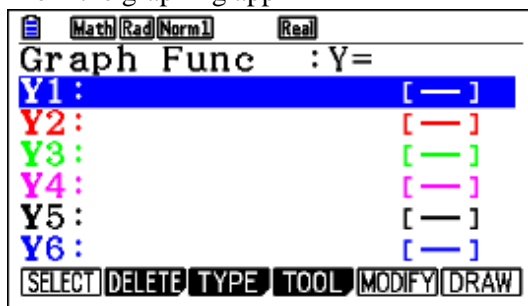

- Press Lp to select **SET UP**.

Make sure that **derivative** is set to **On** in the settings page:

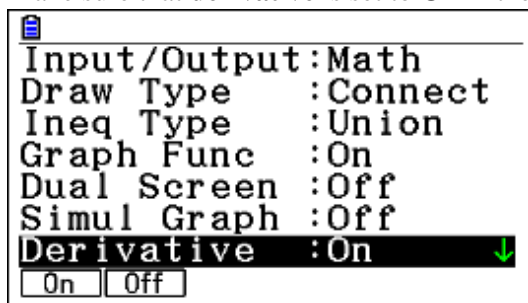

- This enables the display of value of the derivative dy/dx in trace mode. The next examples will show the value of this setting.

Hint: As you notice from the SET UP screen, you can adjust various settings for graphs. Here are some useful information bits:

- Draw Type** Graphs can be drawn by connecting successive points or just by plotting points.
- Connect** Is usually the better choice.
- Ineq Type** When more than one inequality are graphed, you can choose which areas are shaded.
- Graph Func** When this is on, the formula for the graph will be on the screen.
- Dual Screen** When this is on, the screen is divided in half, with either two graphs or a graph and a table showing.
- Simul Graph** When this is on, all graphs are drawn simultaneously.
- Derivative** When on, numerical derivative of a function is displayed when tracing or tabulating.
- Coord** This is usually left on to show coordinates on the screen.

Most others are self-explanatory.

IB Question Types

Numerical derivatives, equation of tangent and normal lines

We will start with a basic example to show the use of the calculator for some typical IB questions. As always, we do not advocate depending solely on the calculator to form our mathematical findings – you will see in the example below that it will not do everything for you nor will it be faster than you all the time!

Example 1

Consider the function $f(x) = 3(1.4)^x$

- Sketch the graph of the function for the domain $0 \leq x \leq 3$.
- Write down the coordinates of the y-intercept.
- On the same grid, draw the graph of the function $g(x) = 4 - 3x$.
- For what values of x is $f(x) = g(x)$?

Exam response:

- Here is a sketch of the graph of $f(x) = 3(1.4)^x$. (Remember to label your axes!)

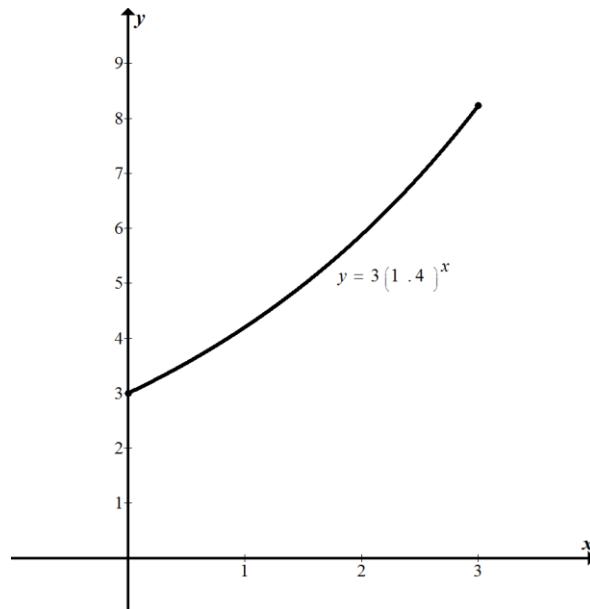

- The y-intercept corresponds to the value of $x = 0$. $(0, 3)$
- Here is a sketch of the graph of $y = 4 - 3x$.

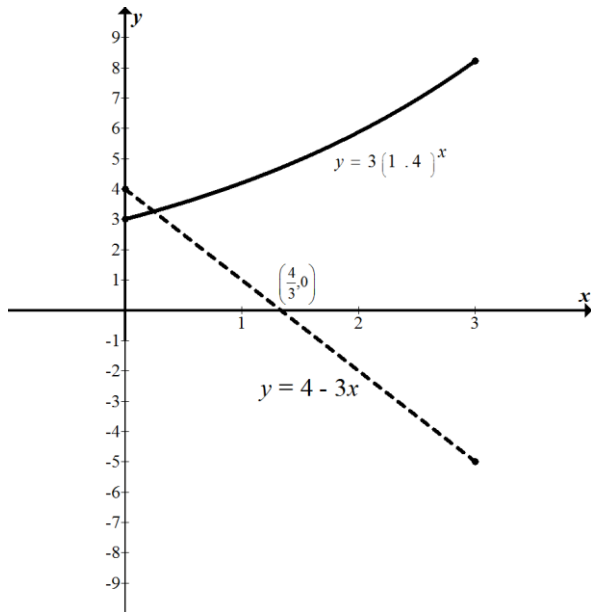

- d. $f(x) = g(x)$ when their graphs intersect. In this domain there is one point of intersection with an x -value of 0.247.

fx-CG50

- a. Here we graph the required function and make a sketch of it on the exam paper.

From the main menu, go to  Graph. Type the equation in.

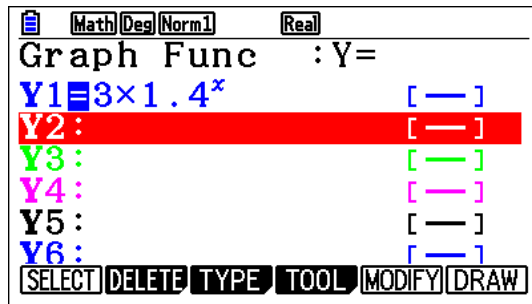

Press u to draw the graph. (Make sure you adjust the viewing window: e)

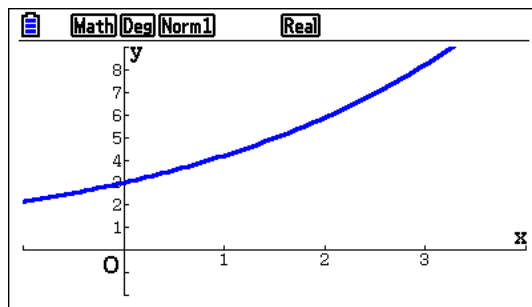

- b. This is really not a gdc question. However, if you need to use one, then Press q01

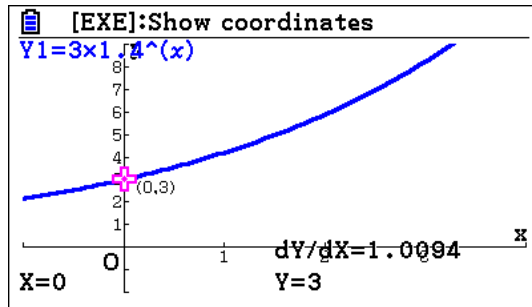

- c. Press \square from the previous screen, type the equation followed by \square

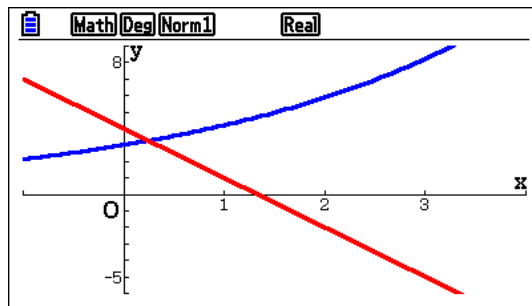

- d. Press \square

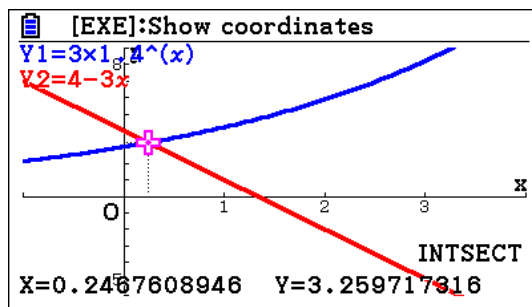

Example 2

Consider the function $y = -x^2 + 2x + 5$.

- Find $\frac{dy}{dx}$.
- Write down the value of the derivative at $x = -1$.
- Find the equation of the tangent to the function at $x = -1$.
- Find the equation of the normal to the function at $x = -1$.
- The normal to the function at $x = -1$ intersects the function at another point. Write down the coordinates of that point.

Exam response:

- (a) This part must be done without the calculator, (but it is not required for subsequent steps).

$$\frac{dy}{dx} = -2x + 2$$

- (b) This is also not gdc intensive as it is simple substitution: $\frac{dy}{dx} = -2x + 2 = 2 + 2 = 4$.

Tip: this problem, specially parts b, c, and, are examples of how it is more efficient and faster for you to do the work without using the gdc even though the gdc can do that same work!

- (c) The value of the derivative at this point is the slope of the tangent, namely 4.

The point $(-1, 2)$ is on the tangent and hence the equation is

$$y - 2 = 4(x + 1) \Rightarrow y = 4x + 6.$$

- (d) The equation of the normal can be found in same way as the equation of the tangent.

The slope of the normal is $-\frac{1}{4}$ and hence the equation of the normal at $x = -1$ is

$$y - 2 = -\frac{1}{4}(x + 1) \Rightarrow y = -\frac{1}{4}x + \frac{7}{4}$$

- (e) To find the second point of intersection, we solve the system of two equations:

$$y = -x^2 + 2x + 5 \text{ and } y = -\frac{1}{4}x + \frac{7}{4}$$

Hence the second point of intersection is **(3.25, 0.9375)**.

fx-CG50

- b. To find the value of the derivative on the calculator, start by entering the function in the graphing app. The screen should look like this when you are finished:

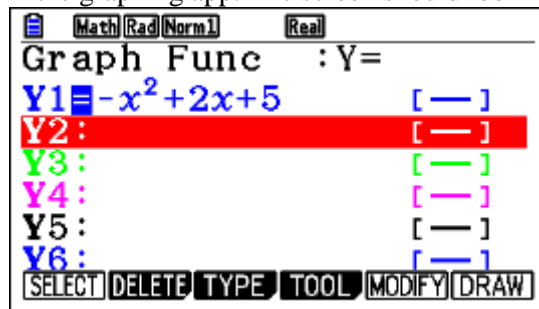

Select u to **DRAW** the function:

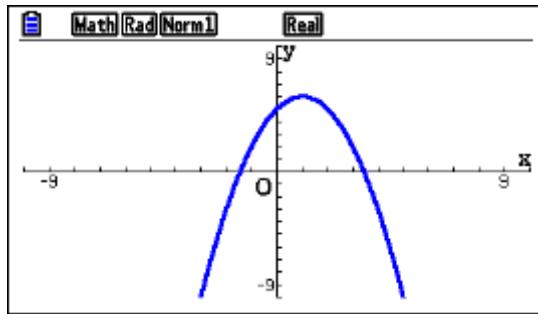

Press **w** to **trace** the function:

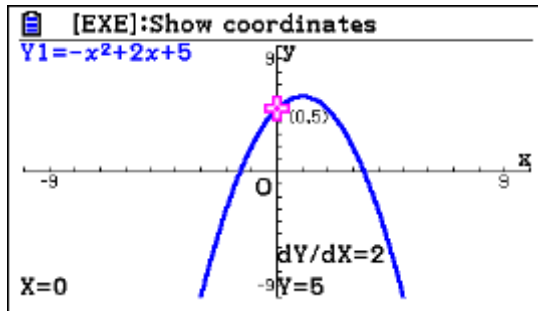

The graph is now in **trace mode**. You can find values of (x, y) and $\frac{dy}{dx}$ by using the arrow keys, or, more precisely, by entering values directly.

Press **n1** to find the value of the derivative at $x = -1$:

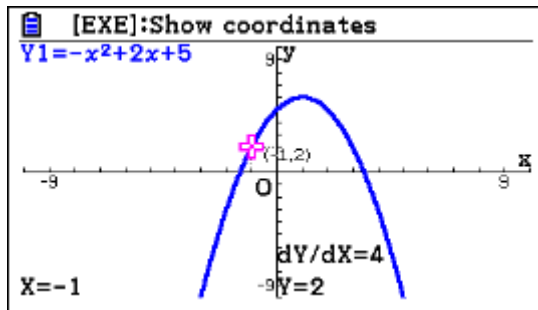

Hence, at $x = -1$ we now know that $\frac{dy}{dx} = 4$.

c. The equation of the tangent can be found with the calculator. Start from the graph:

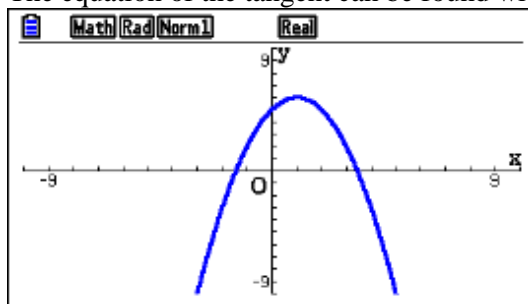

Press **r** for **Sketch mode**:

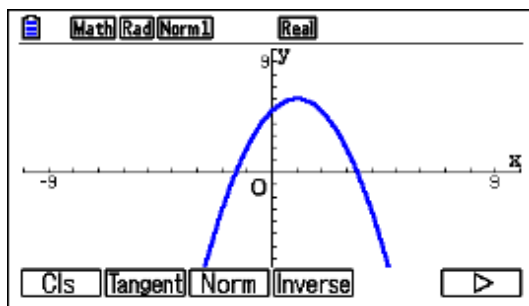

Press \square for **Tangent**:

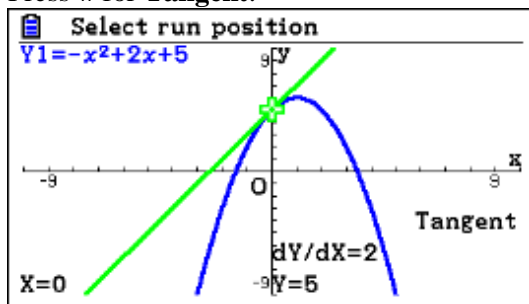

Tip: if the dY/dX does not appear, you need to enable Derivative mode – see the settings at the beginning.

Enter n1 with the keypad:

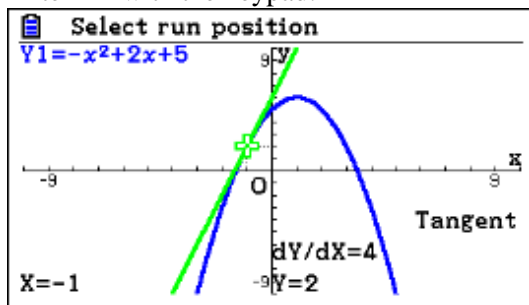

Press \square to find the equation of the tangent at $x = -1$:

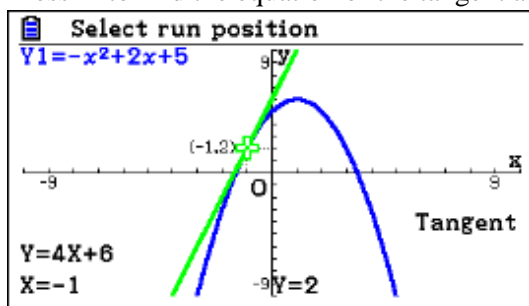

Hence, the equation of the tangent at $x = -1$ is $y = 4x + 6$.

Tip: If the equation of the tangent does not appear, you need to enable Derivative mode – see the settings at the beginning!

Tip: To erase the tangent line from your graph, do \square (Sketch) \square (Cls).

- d. The equation of the normal can be found in same way as the equation of the tangent.

From the graph, press \curvearrowright for **Sketch mode**:

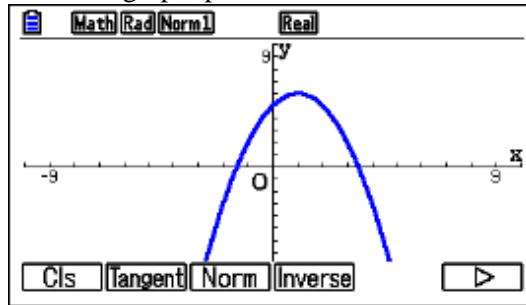

Press F3 for **Normal**:

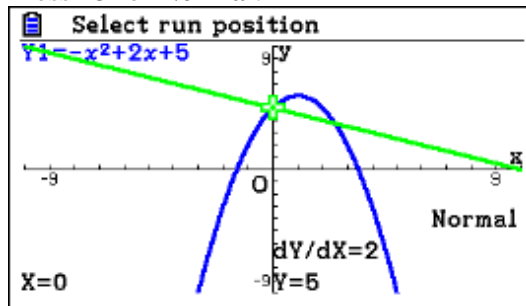

Enter n1 with the keypad:

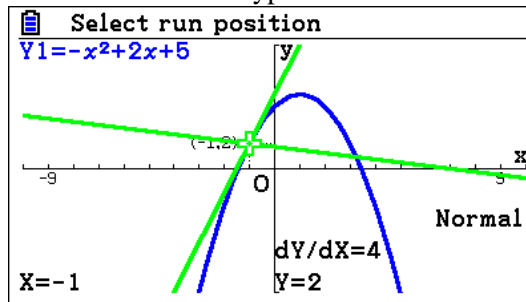

Press EXE to show the equation of the normal:

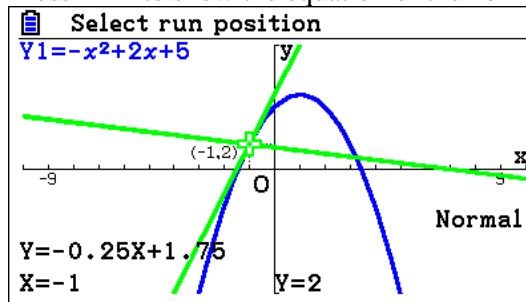

Hence the equation of the normal at $x = -1$ is $y = -0.25x + 1.75$

- e. To find the second point of intersection, write down the equation of the normal from the

previous display, and enter it into the function list:

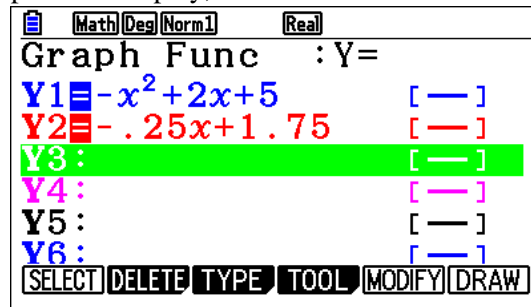

Press u to enter draw mode:

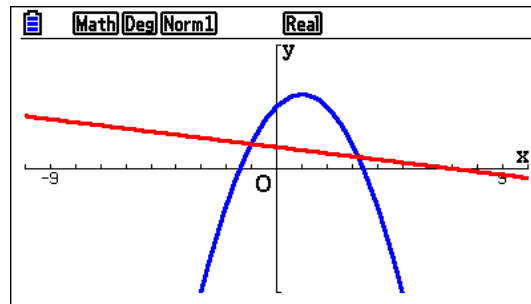

Press y to enter G-Solv mode:

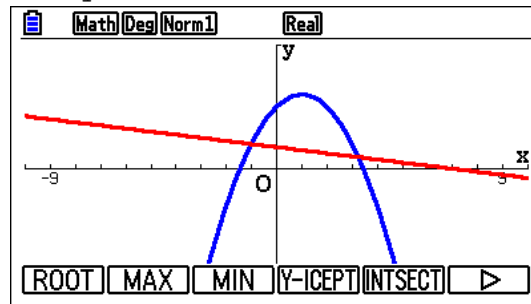

Press y for Intersection mode:

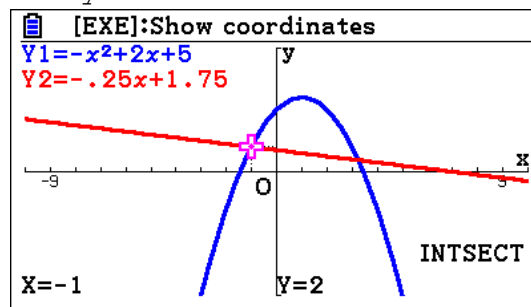

Use the right arrow key \rightarrow to select the second point of intersection:

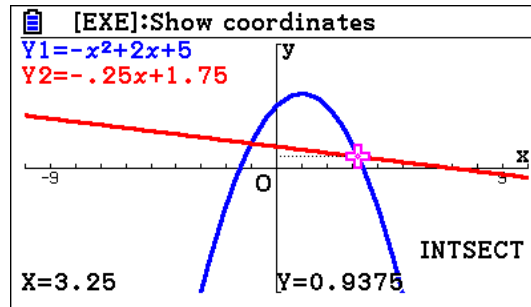

Hence the second point of intersection is $(3.25, 0.9375)$.

IB Question Types

Basic graphing concepts

The IB syllabus indicates that “investigation of key features of graphs, such as maximum and minimum values, intercepts, horizontal and vertical asymptotes and symmetry, and consideration of domain and range” are included. In this part, we will work with these concepts and demonstrate how the *fx-CG50* can be used to help us in working out such investigations.

We are using the words “help us” because, even though the gcd we have has powerful features, but we do not advocate depending solely on it to form our mathematical findings.

Example 3

An oil platform in the North Sea is located 20 km from a pumping station on the shore as shown. A pipe has to be laid to connect the platform to the station. The cost of laying the pipe in water is €800000 per km, and the cost of laying it along the shore is €200000 per km.

Find the minimum cost and the distance along the shore where the pipe reaches land in order to achieve that minimum.

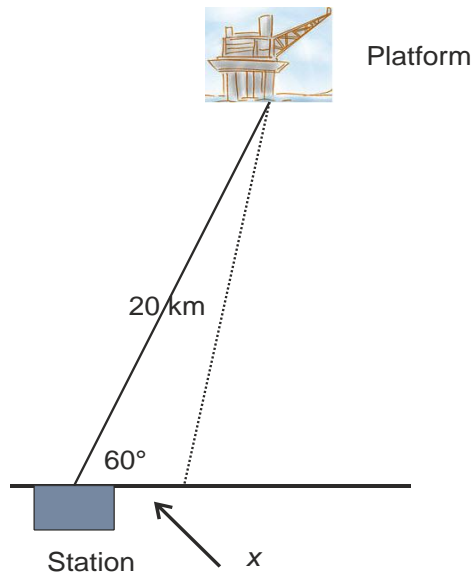

Exam response:

Let the distance from the station down to where the pipe gets on land be x . The distance d from the platform to the shore is then given by the law of cosines:

$$d^2 = 20^2 + x^2 - 2 \cdot x \cdot 20 \cdot \cos 60^\circ = x^2 - 20x + 400, \text{ i.e.}$$

$$d = \sqrt{x^2 - 20x + 400},$$

Now the cost for laying the pipe will be

$$c(x) = 200000x + 800000d = 200000x + 800000\sqrt{x^2 - 20x + 400},$$

This is the function to be minimized.

The minimum is €15416408 to the nearest Euro and it can be achieved if we lay the pipe to reach the shore at 5.528 km from the station.

Note: That is all you need to write when answering the question. Here is how you can find the minimum using *fx-CG50*.

fx-CG50

Start by entering the function in the graphing app.

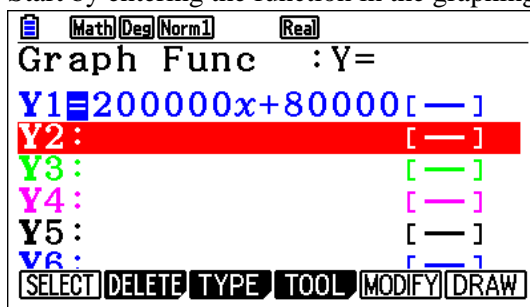

Then press \downarrow or \rightarrow to draw it, (If the graph does not show, then you need to change the viewing window!)

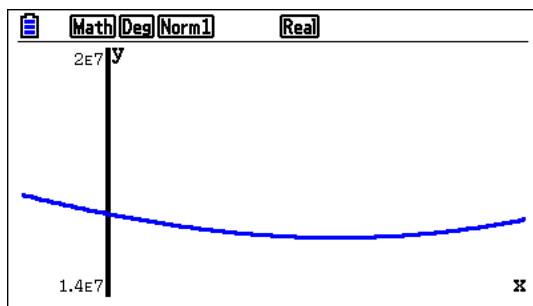

Now press γ to get the submenu for **G-Solv**, then ϵ to get the **MIN**

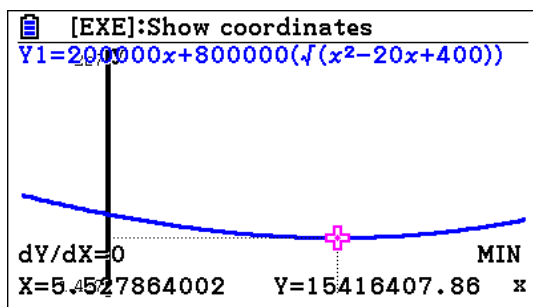

Example 4

A sketch of the function $f(x) = 12x^5 - 5x^3 + 1$ is shown for $-1 \leq x \leq 1$ and $-2 \leq y \leq 4$.

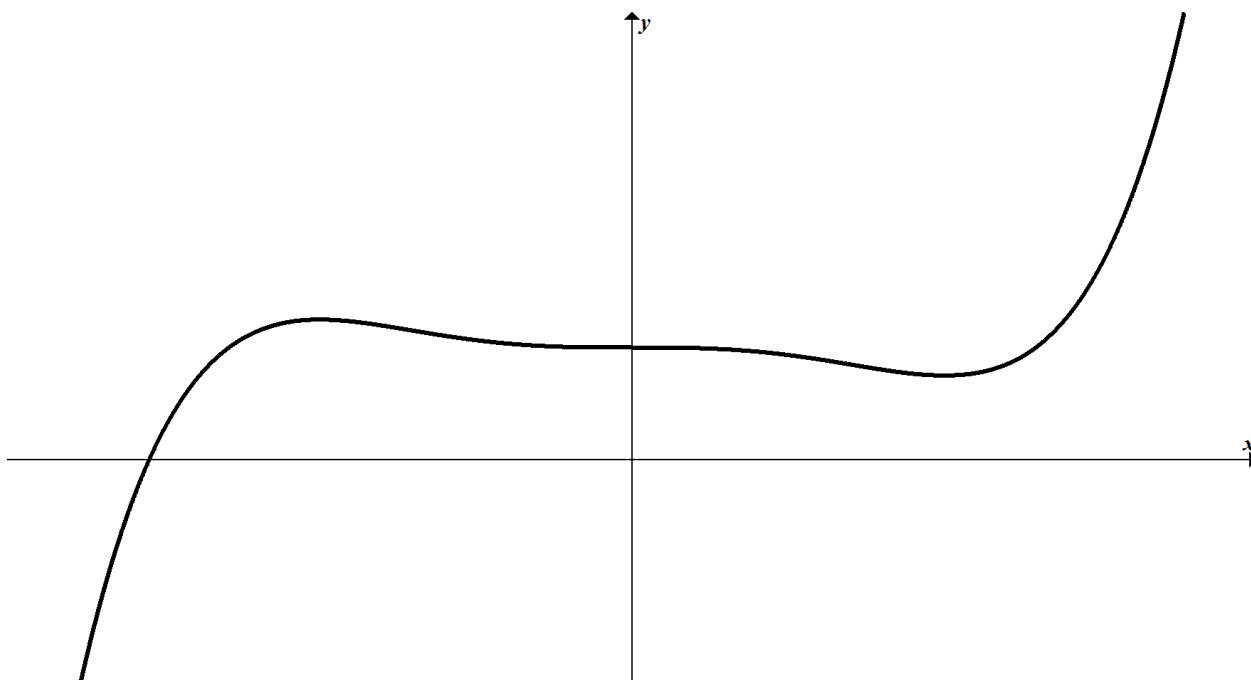

- Find the equation of the tangent line to the graph of the function at its y -intercept.
- Write down the coordinates of the other points of intersection between the tangent line and the function.

For SL/HL

- c. Find the area enclosed between the function and its tangent.

For HL

- d. Find the volume generated as you rotate the enclosed region about the y -axis through 360° .

Exam response:

- a. This is a MS question.

The y -intercept is the point where $x = 0$. In this case it is $(0, 1)$.

For the tangent line equation we need the slope at this point.

$$\frac{dy}{dx} = 60x^4 - 15x^2 = 0$$

Thus the tangent line is the horizontal line $y = 1$.

- b. The points of intersection between the function and the tangent can be found by equating the two expressions:

$$12x^5 - 5x^3 + 1 = 1 \Rightarrow 12x^5 - 5x^3 = 0$$

$$x^3(12x^2 - 5) = 0 \Rightarrow x \in \{0, \pm 0.645\}$$

- c. The area between the function and its tangent is found by evaluating the following integral

$$\begin{aligned} \text{Area} &= \int_{-0.645}^0 \left((12x^5 - 5x^3 + 1) - 1 \right) dx + \int_0^{0.645} \left(1 - (12x^5 - 5x^3 + 1) \right) dx \\ &= \int_{-0.645}^{0.645} \left| (12x^5 - 5x^3 + 1) - 1 \right| dx = 0.145 \end{aligned}$$

- d. The requested volume can be found by evaluating the following integral.

Volume =

$$\begin{aligned} &2\pi \int_{-0.645}^0 x \left((12x^5 - 5x^3 + 1) - 1 \right) dx + 2\pi \int_0^{0.645} x \left(1 - (12x^5 - 5x^3 + 1) \right) dx \\ &= 4\pi \int_0^{0.645} \left| x \left(1 - (12x^5 - 5x^3 + 1) \right) \right| dx = 0.402 \end{aligned}$$

fx-CG50

- a, b. From the main menu we go to **Graph** app. Type in the expression for the function
 Make sure that the viewing window is [-1, 1] by [-2, 4] for a clear drawing. Also remember to enable dY/dX in **SET UP**.

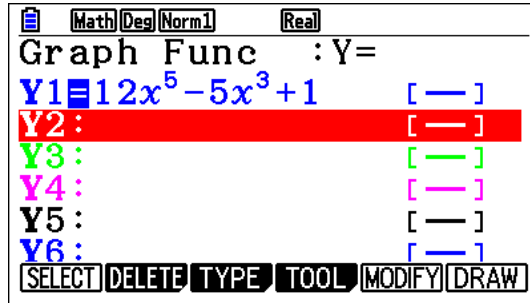

Press u to draw, and then q to trace.

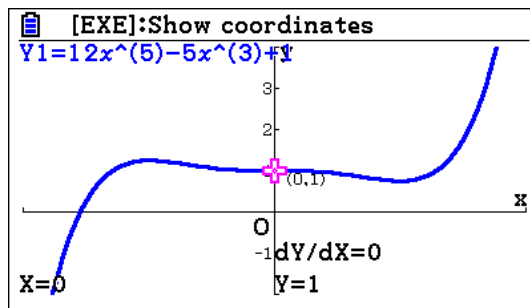

By default you receive the y-intercept and the value of the first derivative.

Since the slope is 0, the equation of the tangent is $y = 1$.

Press d, and in Y2 type 1 then 1 followed by u for **DRAW**.

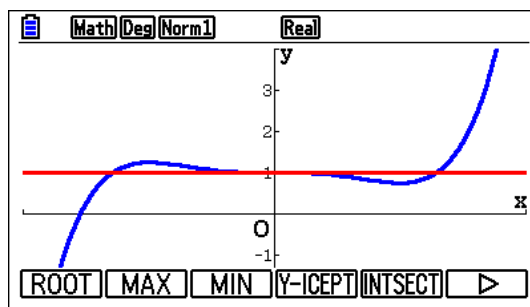

Press y to read the points of intersection. To get all of them you need to press \$ twice.

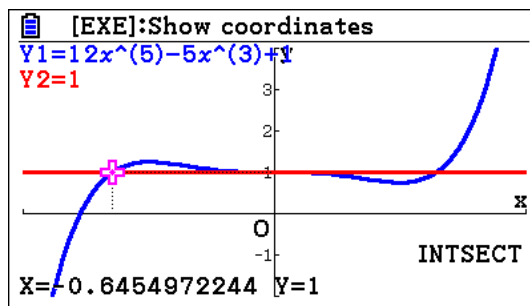

Alternatively, after pressing u to draw the graph of the function, press r followed by w to get the tangent

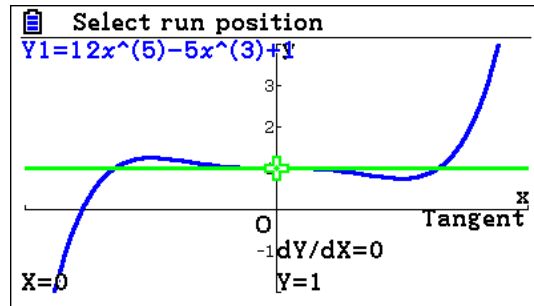

- c. To find the area, in the **Graph Func** window, make sure that both functions are selected.

u to draw, then y to get to **G-Solv**, then u to go to next page, e to get to integration,

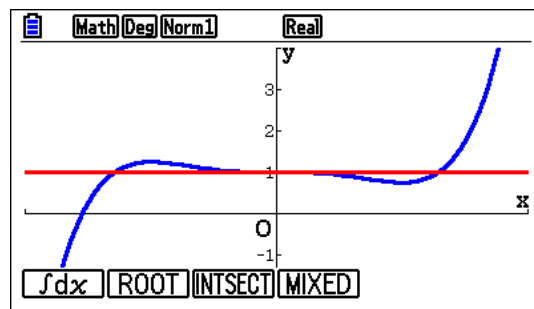

Press r for **MIXED**

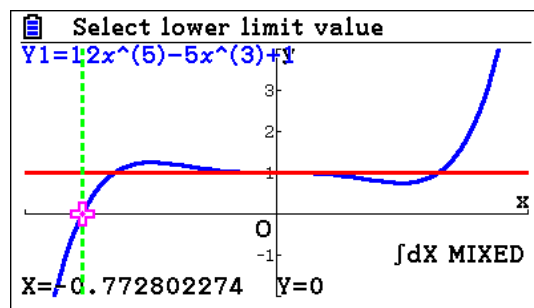

Now § to get to the lower limit, then 1

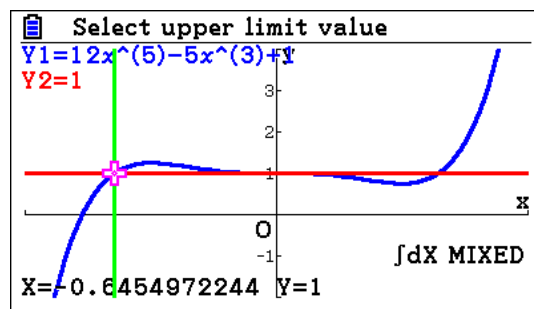

§§1 to get to the upper limit, 1

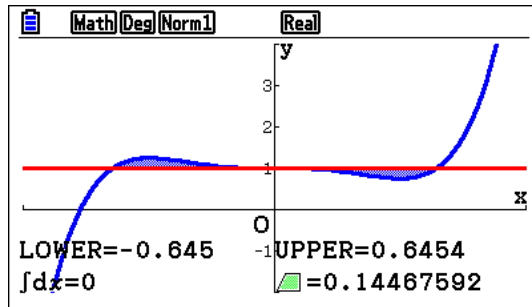

d. In the **Graph Func** window, enter **Y3** as $4\pi|x(Y1-1)|$:

4Ciyqf (ddq1-1) d

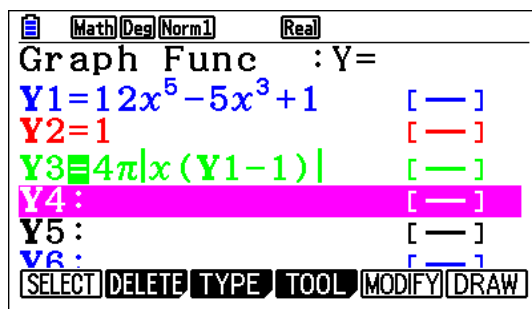

Press uyueq010.6451

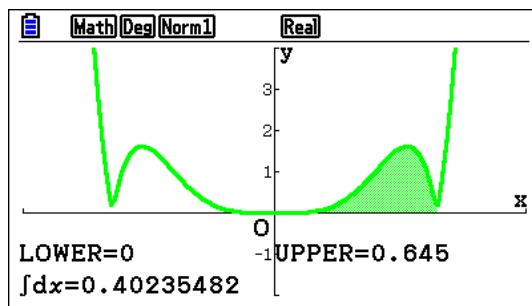

Example 5

The graph of $f(x) = x^2$ is transformed into the graph of $g(x) = 2x^2 - 12x + 25$ by a sequence of 3 transformations. Write down these transformations.

Exam response:

In order to find the transformations, we write $g(x)$ in the form $g(x) = a(x-b)^2 + c$.

$g(x) = 2(x-3)^2 + 7$, and we conclude that the transformations are:

- A vertical stretch by a factor of 2, followed by
- A horizontal shift of 3, and
- A vertical shift of 7.

Note: Notice that in answering such questions you do not need to say that you used the gcd for your answer. However, the gcd is used to enable you to find b and c .

fx-CG50

We graph the function and find its minimum as we did earlier.

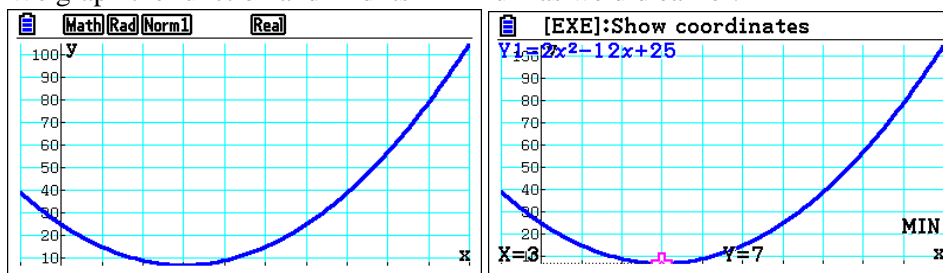

Thus the horizontal shift is 3 and the vertical shift is 7. The vertical stretch is obvious by looking at the coefficient of x^2 .

Example 6

Consider the function $f(x) = x(x-2)^3$.

- Find for what values of x is $f(x)$ increasing?
- Sketch the graph of this function and label its extreme points and inflection points.
- Solve the inequality $f(x) > x - 2$.
- Find the area of the region enclosed between the graphs of the functions $f(x)$ and $h(x) = x - 2$.

Exam response:

Note: Before you start, note that this problem should not be treated completely using your gcd. You must show work leading to your responses. Your gcd will prove to be very helpful in making the task simpler than it appears.

- For $f(x)$ to be increasing, then $f'(x) > 0$.

$$f'(x) = (x-2)^3 + 3x(x-2)^2 = 2(x-2)^2(2x-1)$$

Since $2(x-2)^2 > 0$ for all values of x except when $x = 2$, then

$$f'(x) > 0 \text{ whenever } 2x - 1 > 0,$$

Thus $f'(x) > 0 \Rightarrow x > \frac{1}{2}$ and $x \neq 2$, or equivalently $x \in \left] \frac{1}{2}, 2 \right[\cup] 2, \infty[$

- b. Since $f'(x) = 0$ at $x = \frac{1}{2}$ and switching from negative to positive values, there is a minimum value for $f(x)$ at $\left(\frac{1}{2}, -\frac{27}{16} \right)$ using the first derivative test.

To find the points of inflection we find the second derivative

$$f''(x) = 4(x-2)(2x-1) + 4(x-2)^2 = 12(x-1)(x-2)$$

This gives us 2 points of inflection: $(1, -1)$ and $(2, 0)$

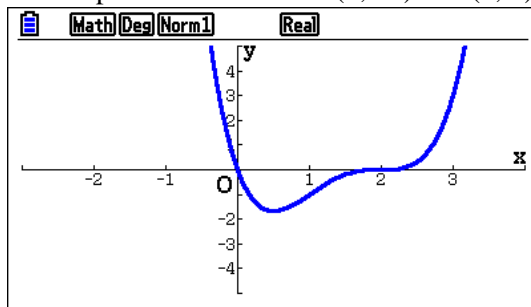

On exams you need to make sure to label the coordinate axes, intercepts, extreme values and inflection points as requested.

- c. We can use the sketch produced earlier and graph the new function $y = x - 2$,

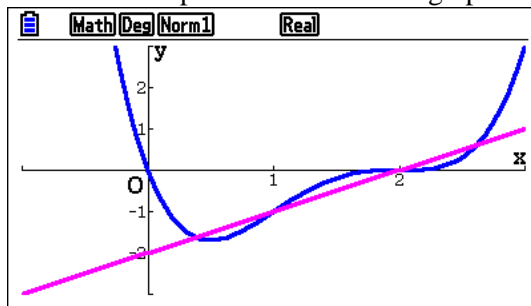

$f(x) > x - 2$ for the intervals where the graph of $f(x)$ is above the graph of $y = x - 2$.

From the sketch, it is clear that $f(x) > x - 2$ for the following values

$$]-\infty, 0.382[\cup] 1, 2[\cup] 2.62, \infty[.$$

- d. We notice here that the enclosed region is divided into three intervals $]0.382, 1[$, $]1, 2[$ and $]2, 2.62[$.

To find the required area, we either integrate the difference of the two functions repeatedly using the positive values, or more eloquently we use the absolute value of the difference, i.e., $|f(x) - (x - 2)|$.

The area is 0.400 square units.

fx-CG50

a. How does the *fx-CG50* help?

First type in the function (here it is Y1) and press 1 then \square to deselect it.

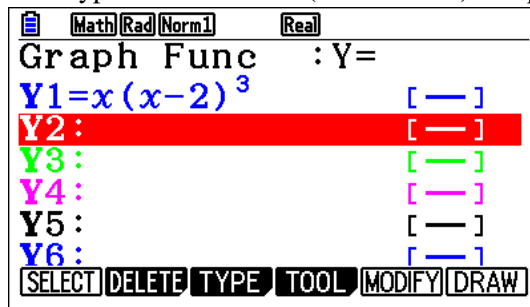

Now press \square

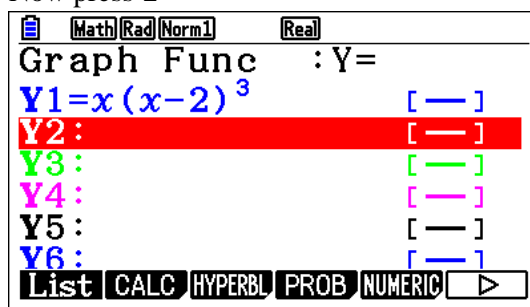

then press \square to choose **CALC** from the menu

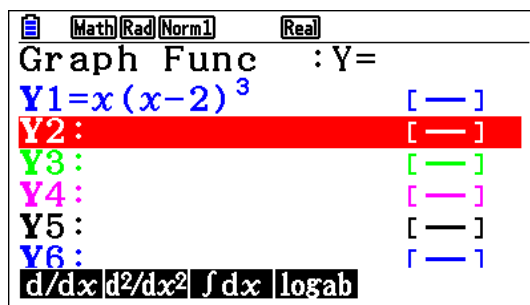

Now choose \square $\frac{d}{dx}$, then \square to choose Y from the menu, type 1, and press \square and replace $x = 0$ in the subscript by $x = x$

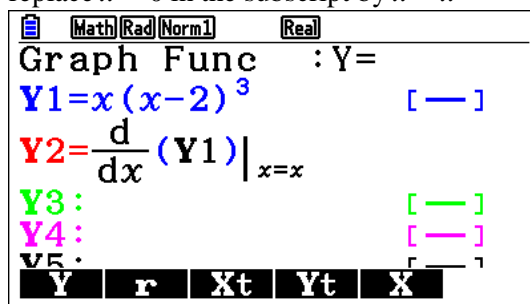

Press \square to graph Y2 to get the graph of the derivative.

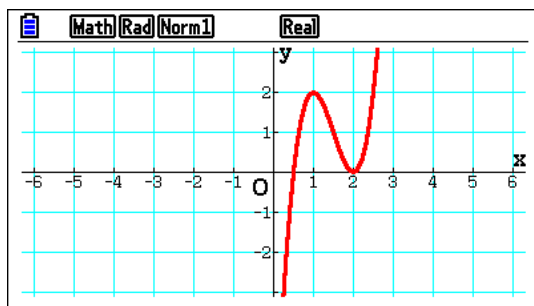

Press \square to trace Y2

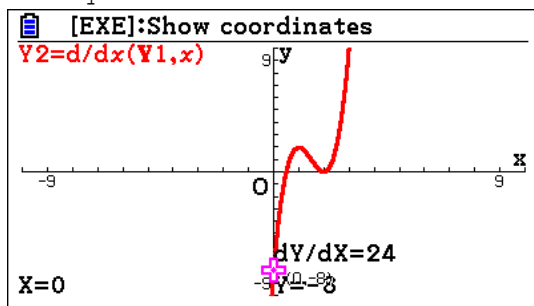

Notice that the value of Y2 is negative. Press $\$$ a few times

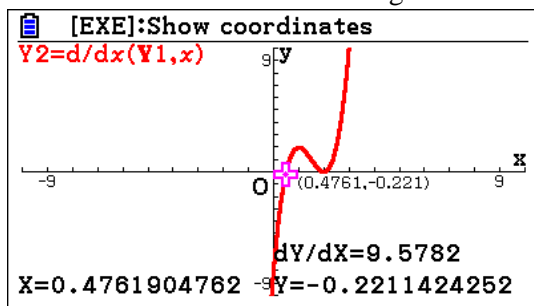

Here you can see that the graph of the derivative is above the x -axis for values of $x > 0.5$ except at $x = 2$.

- b. How does the fx -CG50 help?

After selecting the function and graphing it, press y to get the menu for **G-Solv**,

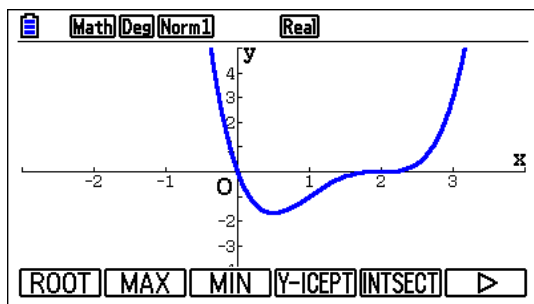

press e to get the minimum

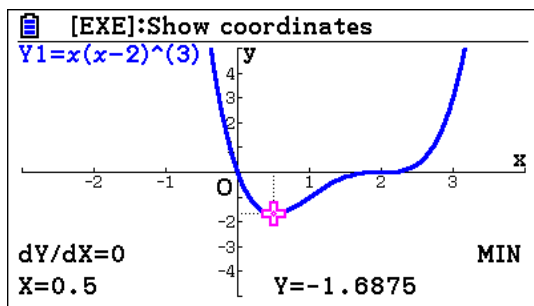

To get the points of inflection, press d to go to the functions window

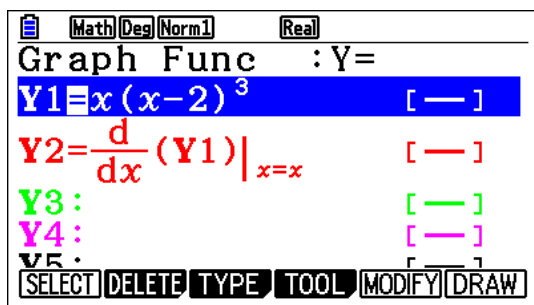

Press i

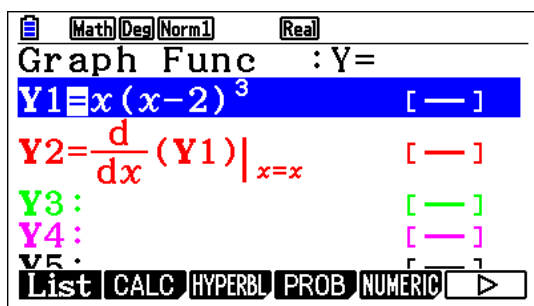

Press w for **CALC**

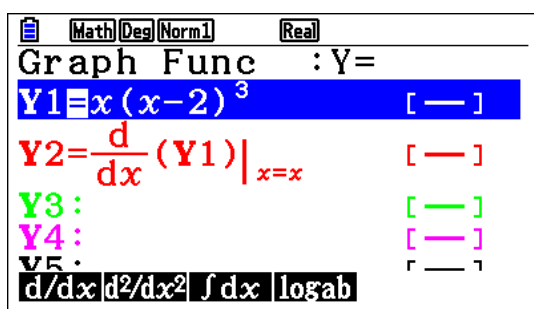

Press NN to Y3 and press w for $\frac{d^2y}{dx^2}$

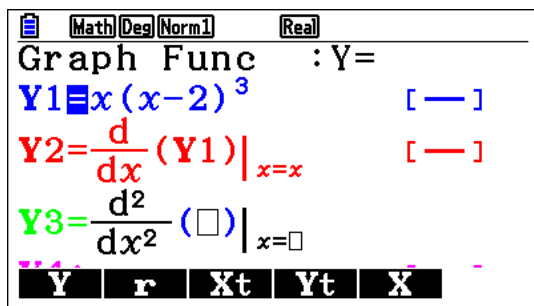

Press \square to choose Y, type 1, press $\$$ to replace 0 with x, 1

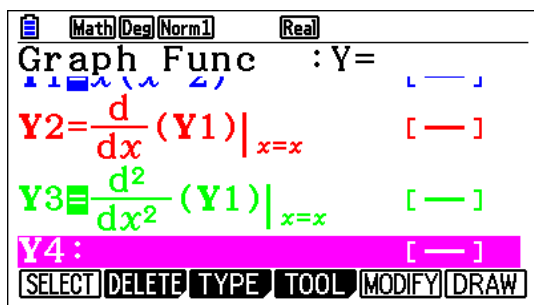

Press \cup to draw the function and the second derivative

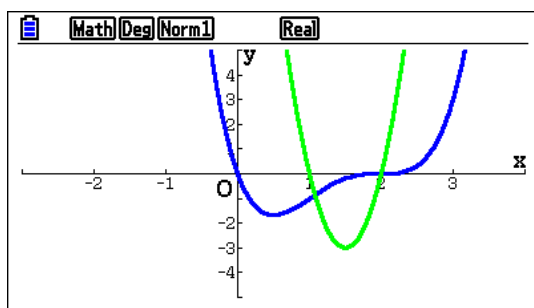

Clearly $\frac{d^2 y}{dx^2} = 0$ when $x = 1$ or $x = 2$, values that correspond to the points of inflection.

Of course you can trace the function Y1 and locate the points of inflection with their coordinates.

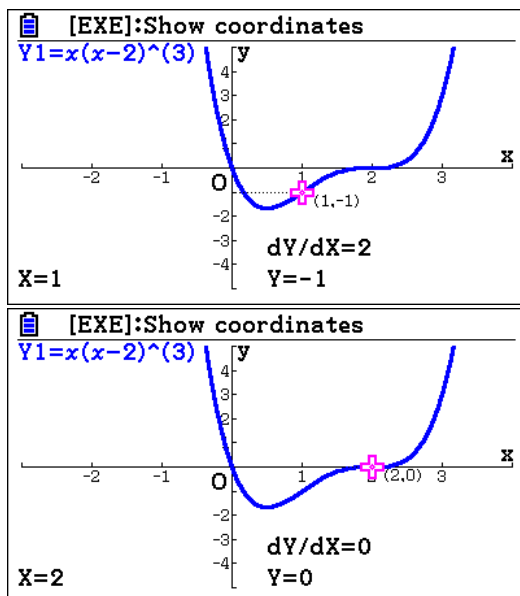

- c. Here the *fx-CG50* can be of great help in several ways. In this chapter, we will consider one of them.

First graph the new function $y = x - 2$, having selected both functions, we graph them and press \square to get the menu for **G-Solv**,

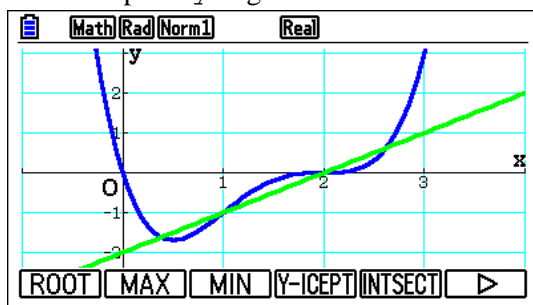

Now press \square to go to the intersection submenu **INTSECT** which gives the first point of intersection, then repeatedly pressing \square we get the rest of the points.

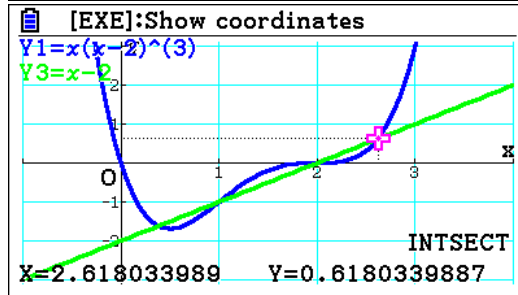
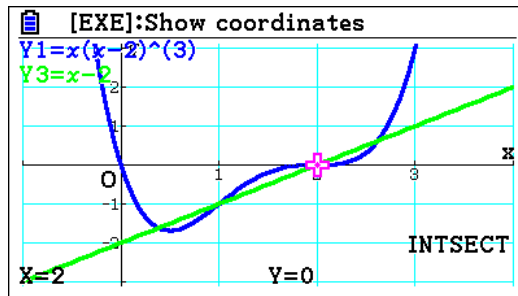
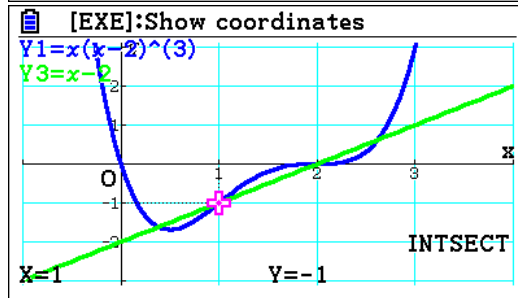
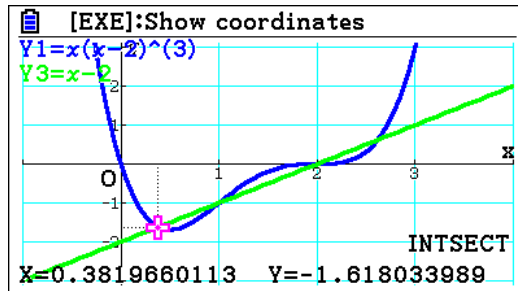

So, the points of intersection are $(0.382, 1.62)$, $(1, -1)$, $(2, 0)$, and $(2.62, 0.618)$.

From the graph, it is clear that $f(x) > x - 2$ for the following values

$$]-\infty, 0.382[\cup]1, 2[\cup]2.62, \infty[.$$

Note: This result can be shown by graphing the inequalities instead.

First, In SET UP, make sure you chose **Ineq Type** to *Intersect*

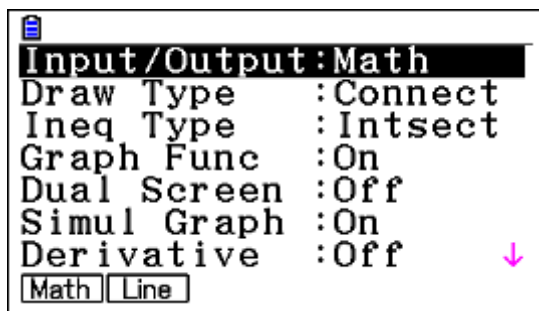

Now, on the **Graph Func** window, go to each of the functions and do the following

Press e (TYPE), then y (CONVERT), then uu (to shade the region below $f(x)$).

Also for $y = x - 2$, e (TYPE), then y (CONVERT), then uuw (to shade the region above the line).

Press u to draw. Then yy to look for the points of intersection.

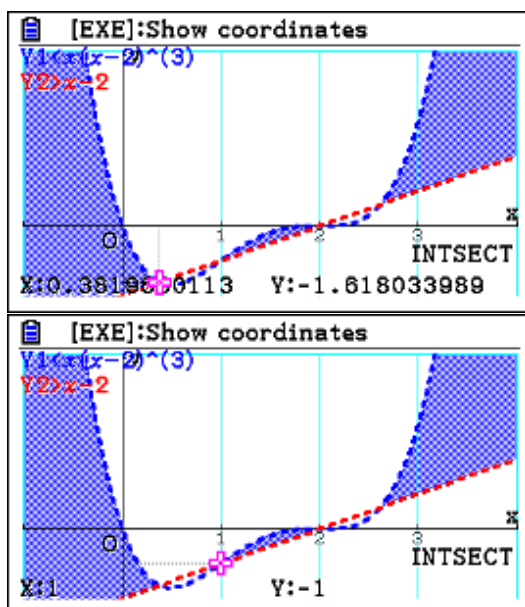

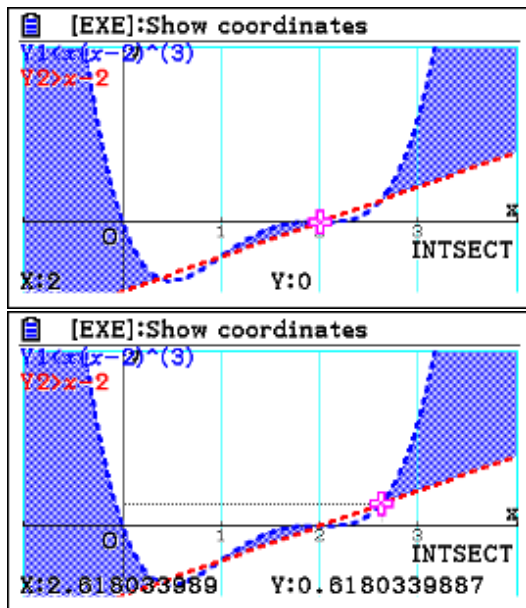

- d. We will use the absolute value of the difference of the two functions $|f(x) - (x-2)|$.

The functions are stored in Y1 and Y4.

In **Run-Matrix** application, press \square for **MATH**, then \square to get the integral

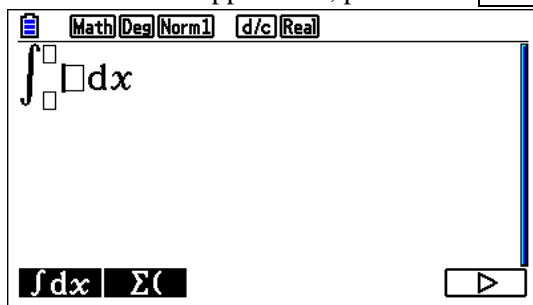

Now press \square or \square

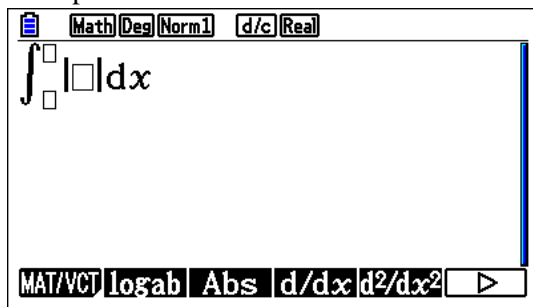

Press \square or \square

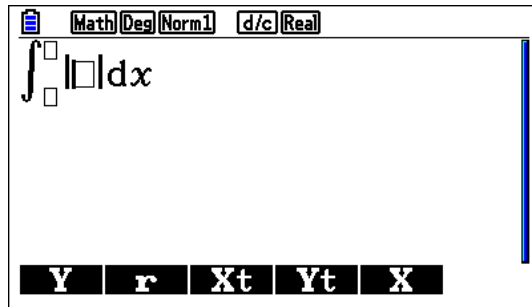

\square , 1, -, \square , 4, \square , .382, 2.62, 1

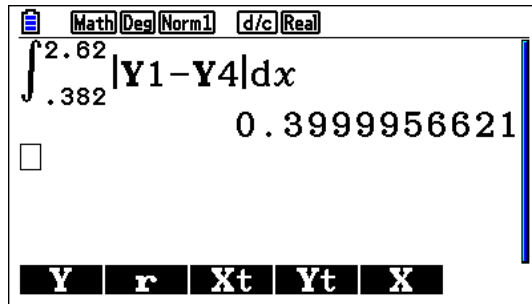

Thus the area of the region is 0.400 square units.

Note: The sequence of keys we presented here is not unique. As you get used to your *fx-CG50*, you will find other sequences of keys that will lead you to the result.

Example 7

Consider the function $f(x) = e^{\frac{x}{2}}$ and $g(x) = ax$, with $a > 0$. Let R be the region enclosed by the y -axis, the graph of f and the graph of g .

- a. Let $a = 2$,
 - i. Sketch the graphs of the two functions on the same system of axes.
 - ii. Find the area of the region R .

- b. Consider the values of a such that the two graphs intersect. Find the value of a that maximizes the area of the region R .

Exam response:

- a. Remember to label your graph. Here is a sketch.

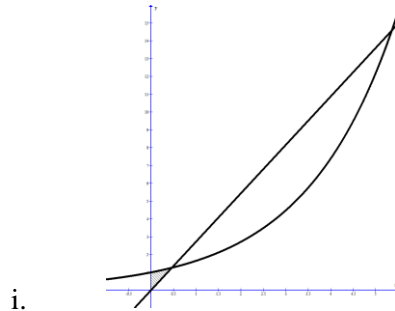

- ii. To find the area of R , we first need to find the leftmost point of intersection between f and g .

The two graphs intersect at $(0.464, 1.261)$.

The area of R can be found by integrating the difference of the two functions

$$\text{Area} = \int_0^{0.464} |f(x) - g(x)| dx = \int_0^{0.464} \left| e^{\frac{x}{2}} - ex \right| dx = 0.2296 \approx 0.230$$

- b. The area as we can see from part (a) is surrounded by the y -axis, the graphs of f and g up to their leftmost point of intersection.

It is obvious that the maximum area is achieved when the line $y = ax$ is tangent to the graph of $f(x)$.

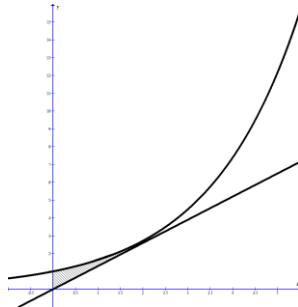

To find a , we need to find the derivative of the function $f(x)$ and equate it to a .

Since we do not know at what point is the line tangent to $f(x)$, we also need to find that point.

We have thus two equations:

$$\text{Equal slopes: } a = f'(x) \Rightarrow a = \frac{1}{2} e^{\frac{x}{2}}$$

$$\text{At intersection: } ax = e^{\frac{x}{2}}$$

Thus $ax = 2a$ and $x = 2$, and hence $a = \frac{e}{2}$.

fx-CG50

- a. ii. To find the point of intersection we first type the functions' equations into the graph window.

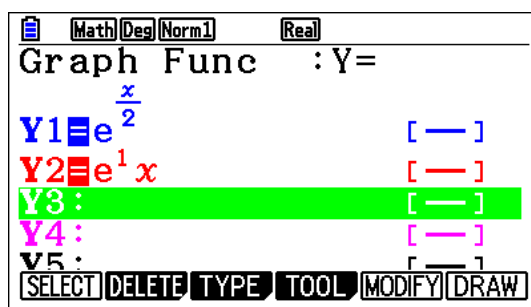

Press \square to **DRAW** the graphs (Remember to adjust the viewing window if needed)

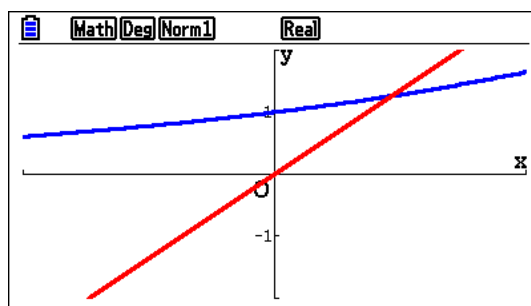

Press \square to get to **G-Solv**, and then \square to look for the intersection.

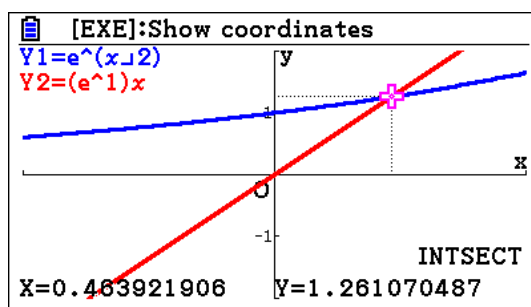

The point of intersection is (0.464, 1.261)

To find the area, we can either integrate the difference of functions between 0 and 0.464, or we find it directly as shown below.

In the Graph window, press \square for **G-Solv**, then \square

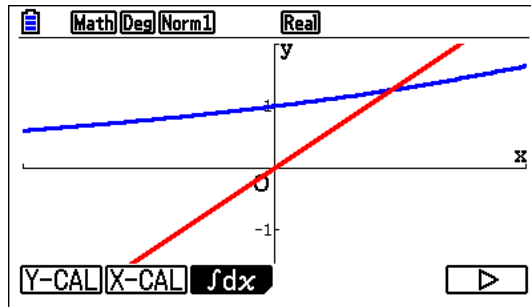

Press e

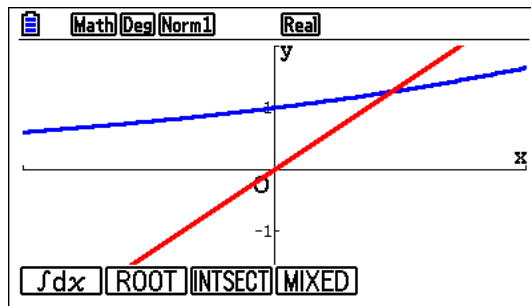

Press r for **MIXED**

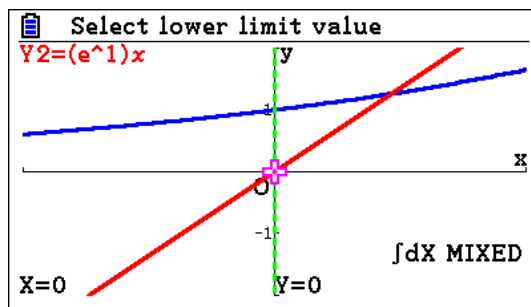

Now 1 to confirm the lower value, then § to confirm the upper value

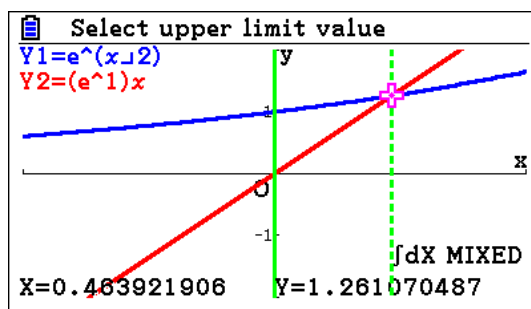

Press 1

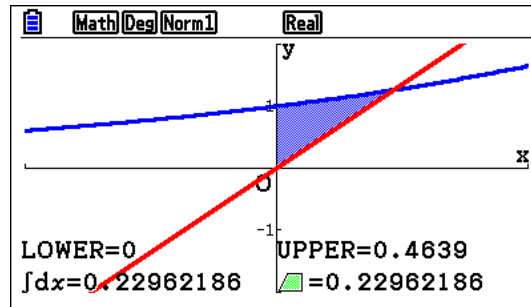

The required area is 0.2296.

- b. The symbolic manipulation appears to be an efficient way of doing this part. However, for verification purposes, we can do the following
In the graph window, press τ for **Sketch**, then w for **Tangent**

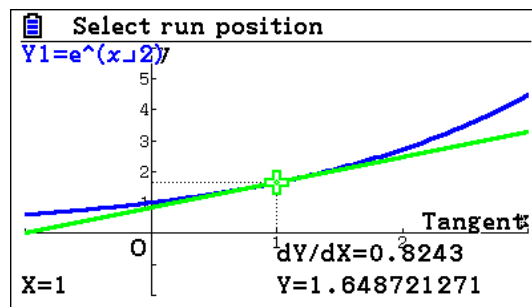

Now with $\$$ or $!$ several times till the tangent passes through the origin

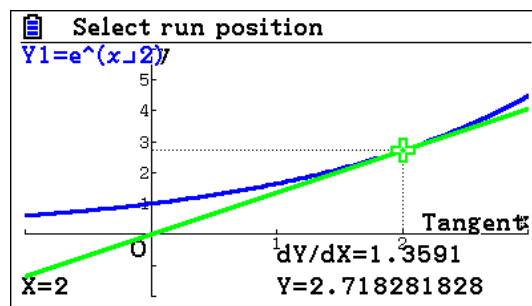

As you observe, $x = 2$ and $\frac{dY}{dX} = a = 1.3591$.

We can also use **Dynamic** graphs.



Press p and scroll to. Dyna Graph

Enter Y2 as $y=ax$ as shown

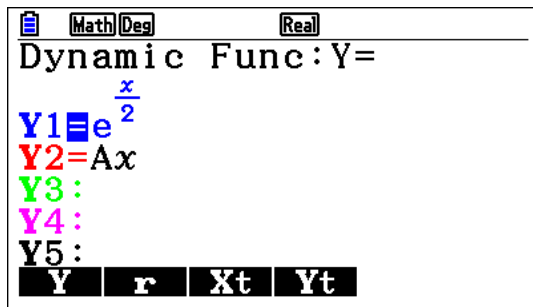

11

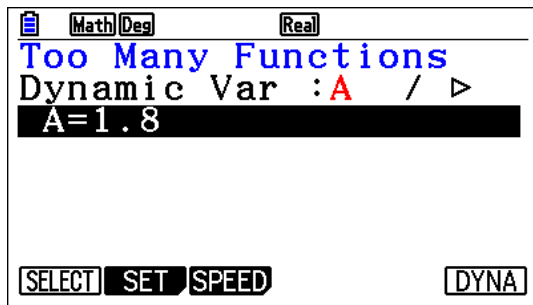

Press w and type in the values as shown

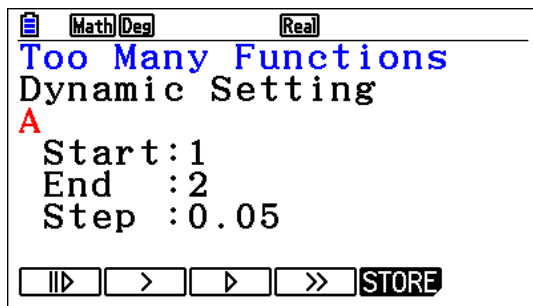

Press 1

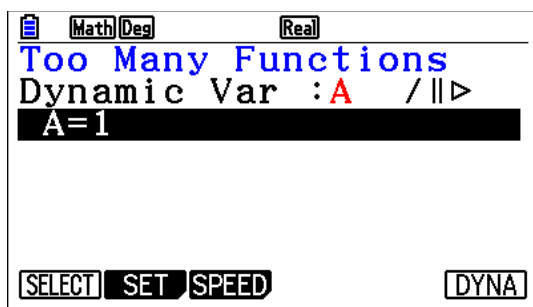

Now u

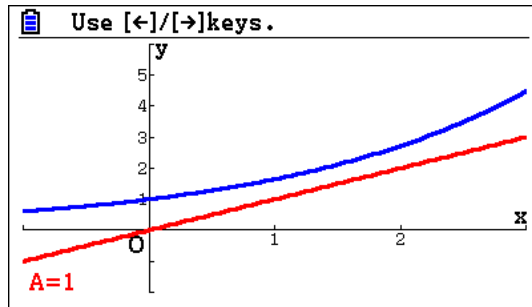

Now press $\$$ several times till you get $y = ax$ to be tangent to $f(x)$

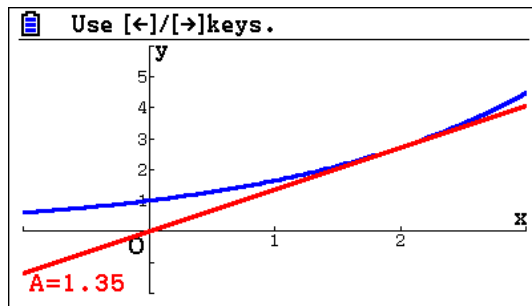

Example 8

Consider the differential equation $2yy' = \cos 2x$.

- Find the general solution of the differential equation. Express your solution in the form $y = f(x)$.
- Find a specific solution of the differential equation, satisfying $y = 1$ when $x = \frac{\pi}{4}$.
Find the range of this function.
- Let R be the region in the xy plane bounded by the function found in (b), the x -axis, and the y -axis.
 - Find the area of R .
 - Find the volume generated when that part of R above the line $y = \frac{1}{2}$ is rotated about the x -axis through 2π radians.

Exam response:

- a. This is a *variables-separable* differential equation. First we separate the variables.

$$2y \frac{dy}{dx} = \cos 2x \Rightarrow 2y dy = \cos 2x dx.$$

Thus

$$\int 2y dy = \int \cos 2x dx \Rightarrow y^2 = \frac{1}{2} \sin 2x + c$$

$$\Rightarrow y = \pm \sqrt{\frac{1}{2} \sin 2x + c}$$

- b. By substituting $x = \frac{\pi}{4}$ and $y = 1$ into $y = \sqrt{\frac{1}{2} \sin 2x + c}$ gives a value of $c = \frac{1}{2}$,

$$\text{So } f(x) = y = \sqrt{\frac{1}{2} \sin 2x + \frac{1}{2}} \text{ with a range of } [0, 1].$$

- c. i. Graphing the function will help us

Identify the upper limit of this region.

The upper limit is where the function intersects the x -axis:

$$\frac{1}{2} \sin 2x + \frac{1}{2} = 0 \Rightarrow \sin 2x = -1$$

Thus $x = \frac{3\pi}{4}$ and the area of the region is

$$\int_0^{\frac{3\pi}{4}} \sqrt{\frac{1}{2} \sin 2x + \frac{1}{2}} dx = 1.707$$

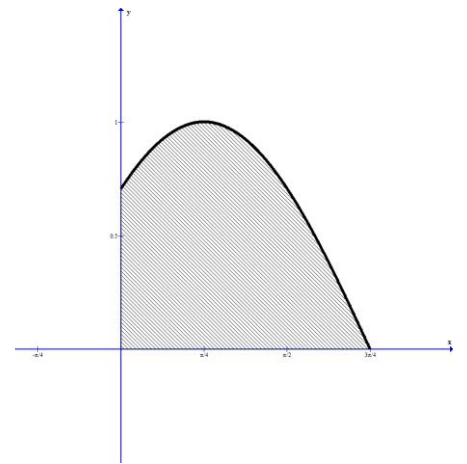

- ii. We need to find the point of intersection between the function $f(x)$ and $y = \frac{1}{2}$ first.

$$\sqrt{\frac{1}{2} \sin 2x + \frac{1}{2}} = \frac{1}{2} \Rightarrow \sin 2x = -\frac{1}{2} \text{ and}$$

$$\text{so } x = \frac{7\pi}{12}$$

The volume is then

$$\pi \int_0^{\frac{7\pi}{12}} \left(\left(\sqrt{\frac{1}{2} \sin 2x + \frac{1}{2}} \right)^2 - \left(\frac{1}{2} \right)^2 \right) dx = 2.90$$

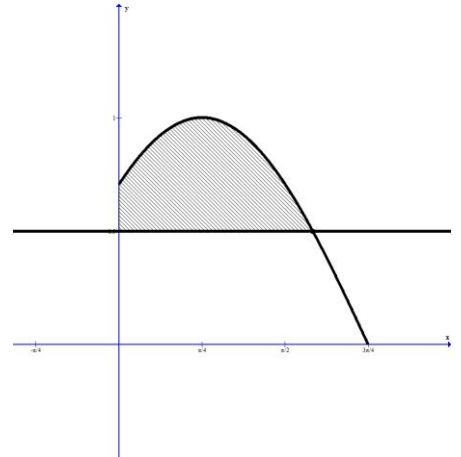

fx-CG50

- a. This is non gcd
b. simple substitution. GDC not recommended.

However, if you choose to use it, here is how:

Go to **Graph** and enter the equation

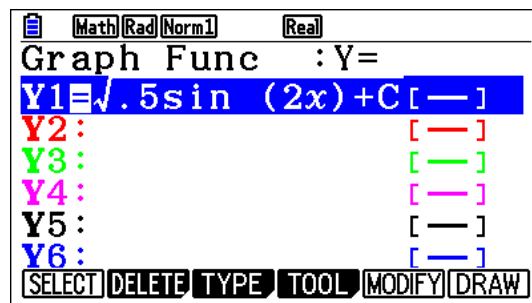

Then go to **MENU** and choose **Equation**,

Press eq (RECALL)

Math Rad Norm1 d/c Real

Graph Func

Y1= $\sqrt{.5\sin(2x)+C}$

Y2:

Y3:

Y4:

Y5:

Y6:

Press 1 to choose the function equation

Math Rad Norm1 d/c Real

Eq: $\sqrt{.5\sin(2x)+C}$

C=0.5

Lower=-9E+99

Upper=9E+99

Use \$ to reach, delete and replace x with CM4=11

Math Rad Norm1 d/c Real

Eq: $\sqrt{.5\sin\frac{2\pi}{4}+C}=1$

C=-0.5

Lower=-9E+99

Upper=9E+99

RECALL DELETE SOLVE

Press u

Math Rad Norm1 d/c Real

Eq: $\sqrt{.5\sin\frac{2\pi}{4}+C}=1$

C=0.5

Lft=1

Rgt=1

REPEAT

- c. (i) Go to **Graph**. Replace c by 1M21

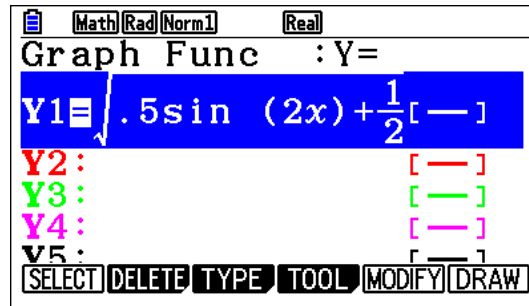

Make sure that you have an appropriate viewing window and press u to draw

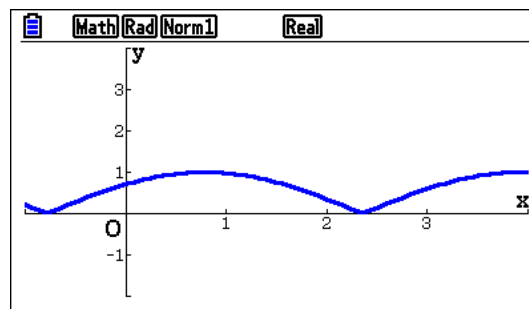

Press yq\$

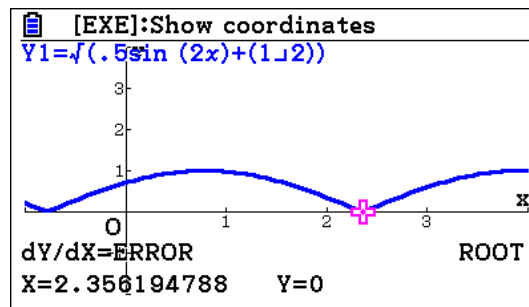

yueq

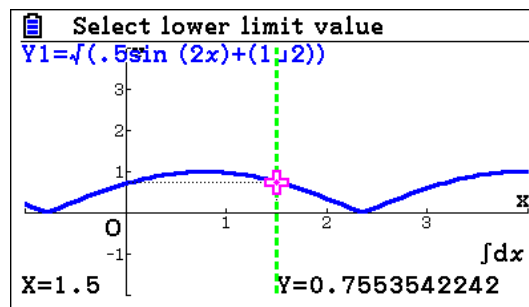

0 1, (either enter 2.356 or scroll to the right to reach 2.356 (approx.)), 1

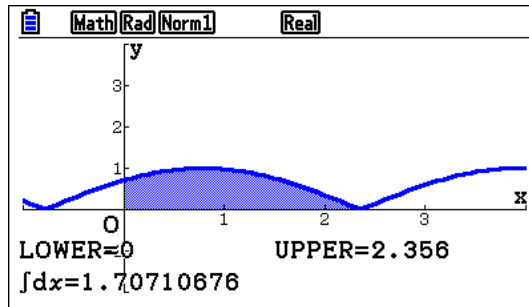

- (ii) Find the point of intersection between $f(x)$ and $y = \frac{1}{2}$

Go to **Run-Matrix** in main menu

iry for SolveN, orq1=0.5 “,” f “,”0“,”C) 1

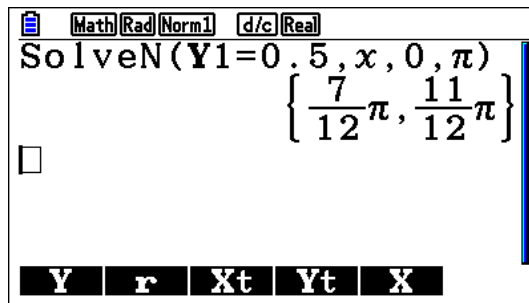

To find the volume:

In **Run-Matrix** app. Press the following sequence

ruqoC (rq1s- 1M4\$0\$7CM121

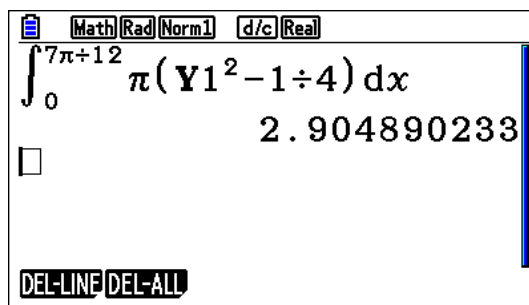

Example 9

A department store has a storage room of width 20 metres and two walls supporting its tilted ceiling. Two spot lights are mounted one at a height 13 metres, the other at a height 8 metres. The lights are synchronized in a way to light the same spot P on the floor at the same time. The intensity of light at point P at ground level on the floor is proportional to the angle θ where $\hat{APB} = \theta$, as shown in the diagram.

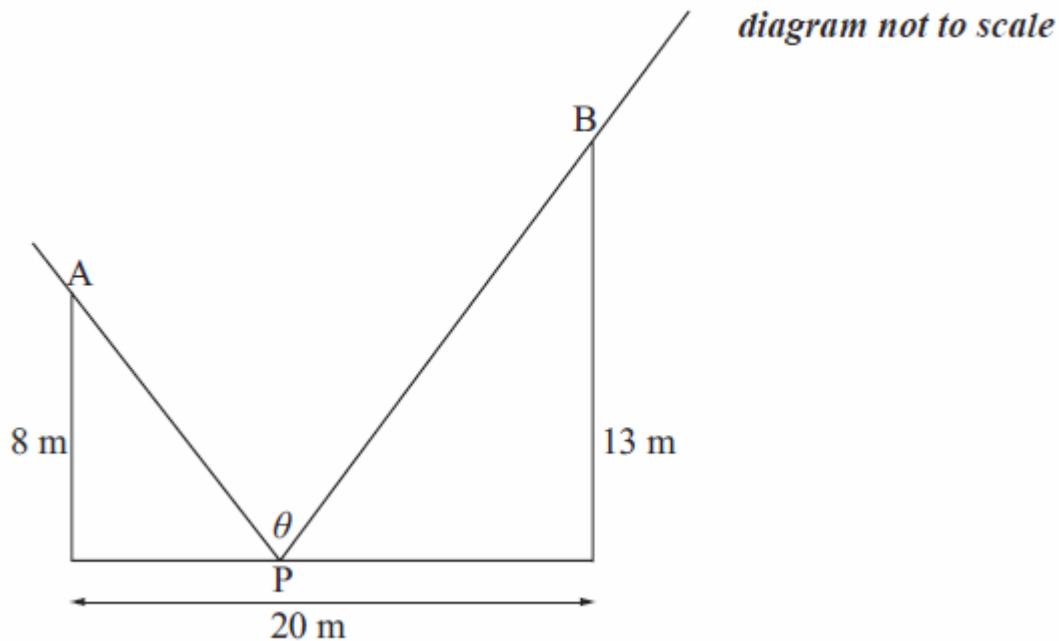

- Find an expression for θ in terms of x , where x is the distance of P from the base of the light at height 8m.
- Calculate the value of θ when $x = 0$.
 - Calculate the value of θ when $x = 20$.
- Sketch the graph of θ , for $0 \leq x \leq 20$.
- Show that
$$\frac{d\theta}{dx} = \frac{5(744 - 64x - x^2)}{(x^2 + 64)(x^2 - 40x + 569)}.$$
- Using the result in part (d), or otherwise, determine the value of x corresponding to the maximum light intensity at P. Give your answer to four significant figures.

- (f) The point P moves across the floor with speed 0.5 ms^{-1} . Determine the rate of change of θ with respect to time when P is at the midpoint of the floor.

Exam response:

- (a) Using alternate interior angles the two angles that add up to \hat{APB} have measures $\text{Arctan} \frac{x}{8}$ and $\text{Arctan} \frac{20-x}{13}$.

$$\text{Thus } \theta = \text{Arctan} \frac{x}{8} + \text{Arctan} \frac{20-x}{13}.$$

- (b) (i) when $x = 0$, $\theta = \text{Arctan} 0 + \text{Arctan} \frac{20}{13} \approx 0.994$

(ii) when $x = 20$, $\theta = \text{Arctan} \frac{20}{8} + \text{Arctan} 0 \approx 1.19$

- (c) Here is a sketch

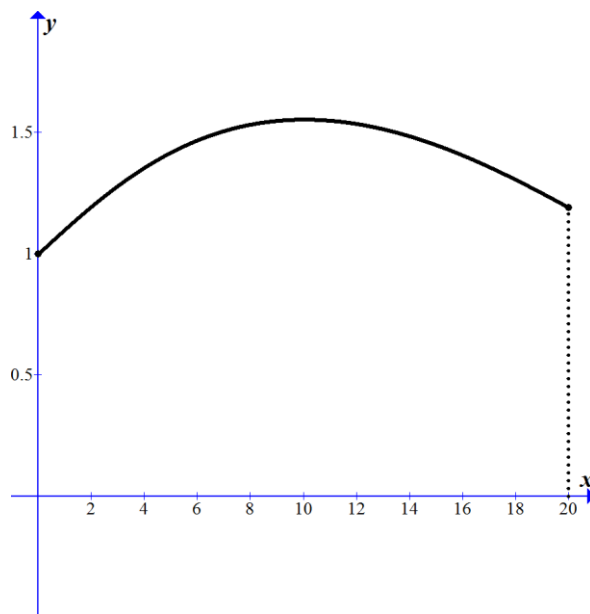

Note: remember to label axes, intercepts and show the domain.

$$\theta = \text{Arctan} \frac{x}{8} + \text{Arctan} \frac{20-x}{13}$$

$$(d) \quad \frac{d\theta}{dx} = \frac{1}{1 + \left(\frac{x}{8}\right)^2} \cdot \frac{1}{8} + \frac{1}{1 + \left(\frac{20-x}{13}\right)^2} \cdot \frac{-1}{13} = \frac{8}{x^2 + 64} - \frac{13}{x^2 - 40x + 569}$$

$$= \frac{8(x^2 - 40x + 569) - 13(x^2 + 64)}{(x^2 + 64)(x^2 - 40x + 569)} = \frac{5(744 - 64x - x^2)}{(x^2 + 64)(x^2 - 40x + 569)}$$

(e) Maximum light intensity happens with a maximum value for θ . Thus, at maximum

$$\text{value } \frac{d\theta}{dx} = 0 \Rightarrow \frac{5(744 - 64x - x^2)}{(x^2 + 64)(x^2 - 40x + 569)} = 0$$

$$x = 10.05$$

(f) We are given that $\frac{dx}{dt} = 0.5$

$$\frac{d\theta}{dt} = \frac{d\theta}{dx} \cdot \frac{dx}{dt}$$

$$\text{However, when } x = 10, \frac{d\theta}{dx} = \frac{5(744 - 64x - x^2)}{(x^2 + 64)(x^2 - 40x + 569)} = 0.000453$$

$$\text{Finally: } \frac{d\theta}{dt} = \frac{d\theta}{dx} \cdot \frac{dx}{dt} = 0.000453 \times 0.5 = 0.000227 \frac{\text{rad}}{\text{sec}}$$

fx-CG50

a. Non GDC. However, because we will use the function expression we can enter it in the **Graph** app.

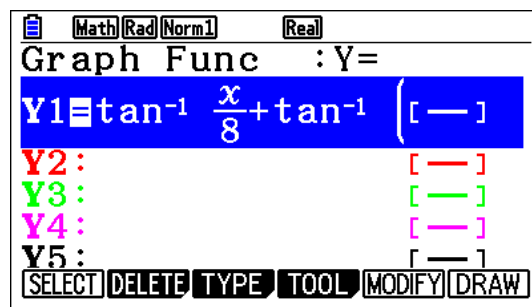

b. (i, ii) Go to **Run-Matrix** app.

Press \square or \square 1 (0) 1,

then use arrows to go back to the expression and replace 0 with 20 and press 1

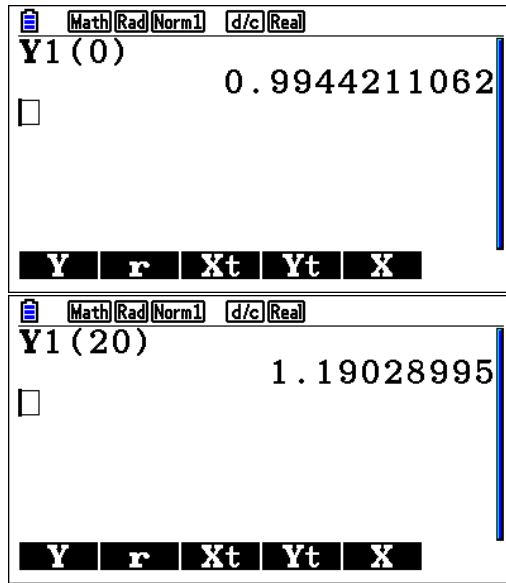

- c. Go to **Graph** app.

Press Le to change the viewing window

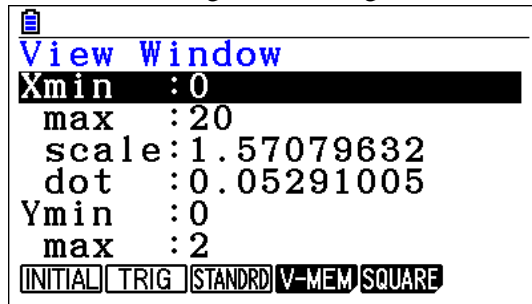

Press du

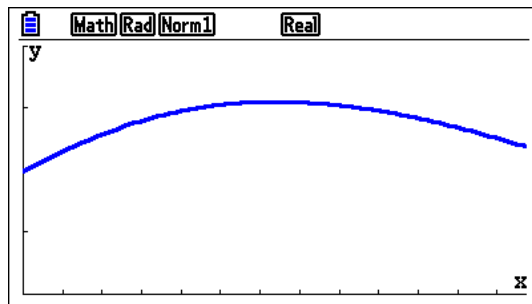

- d. Non GDC
e. Go to **Run-Matrix** app.

Press iryddrr

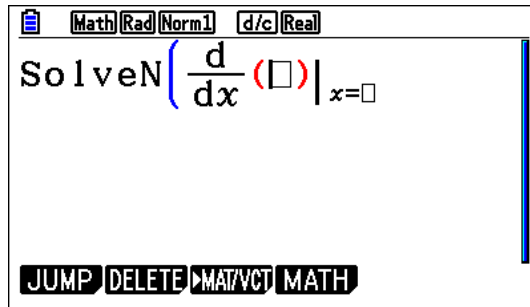

Now press $\text{orq1}\$f\$=0)1$

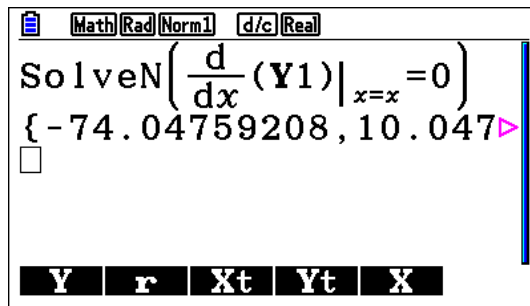

Alternatively, you can specify the domain by adding the following after 0:

$F", "0", "2", "0$

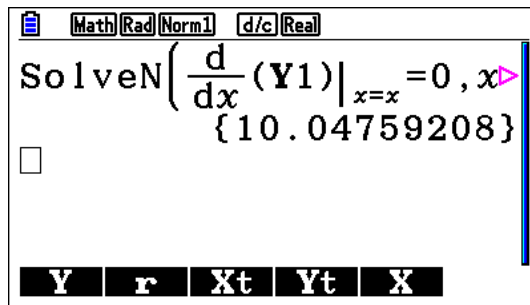

- f. Exit the SolveN window.

Press $\text{rro}\text{rq1}\$101$

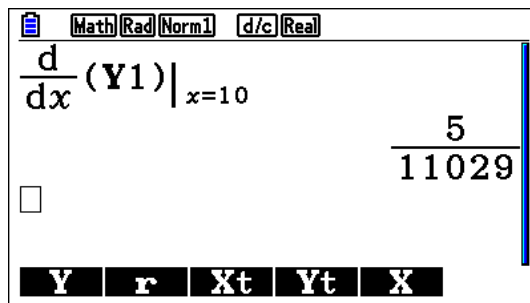

Or if you need the decimal value, press n

Math Rad Norm1 d/c Real

$$\frac{d}{dx}(Y1)|_{x=10}$$

4.533502584E-04

Y r Xt Yt X

Finally, $m_0 = 0.51$

Math Rad Norm1 d/c Real

$$\frac{5}{11029}$$

Ans \times 0.5

22058

Y r Xt Yt X

or

Math Rad Norm1 d/c Real

$$\frac{d}{dx}(Y1)|_{x=10}$$

Ans \times 0.5

2.266751292E-04

Y r Xt Yt X

Example 10

The shaded region is enclosed between the curves $y = 2x + 3\sin x + 1$ and $y = 3x + 2$ for $x \geq 0$.

- Write down the coordinates of the points of intersection.
- Find the area of the region.
- Find the volume of the solid generated by rotating the shaded region by 2π around the x -axis.
- Find the volume of the solid generated by rotating the shaded region by 2π around the y -axis.

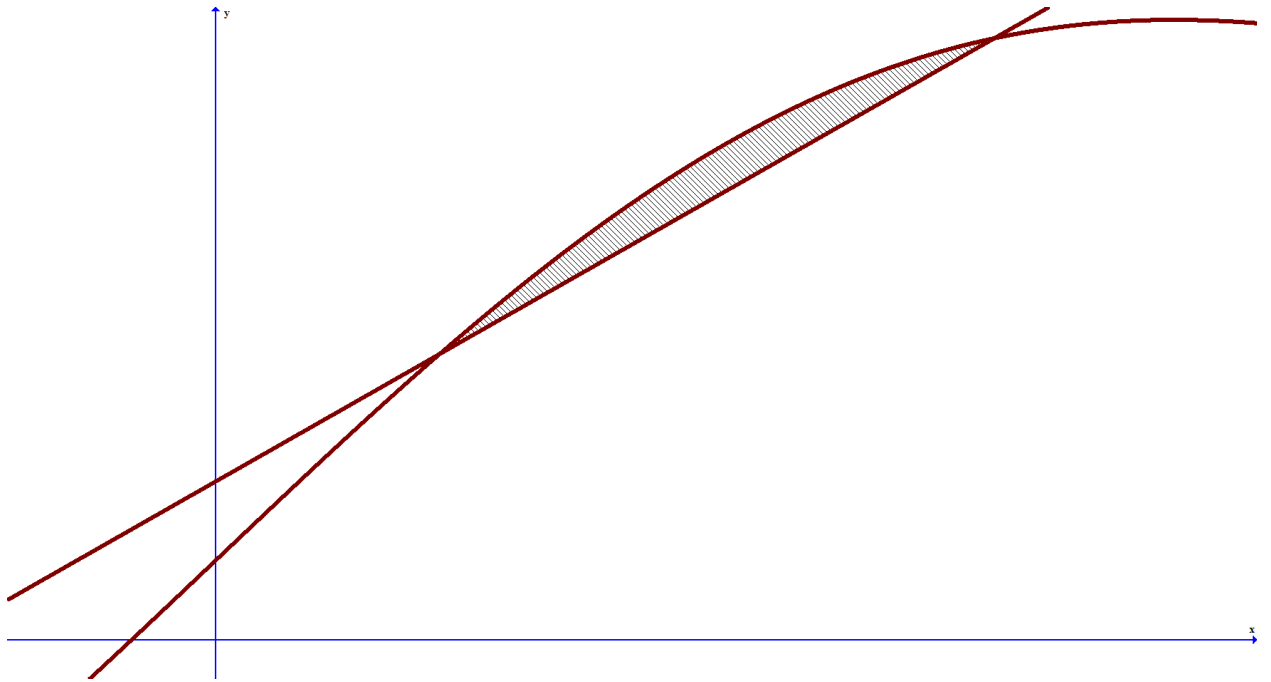

Exam response:

- a. The points of intersection between the two graphs are common to both graphs, hence

$$2x + 3 \sin x + 1 = 3x + 2$$

The points are (0.538, 3.62) and (1.87, 7.60).

- b. The area of the shaded region can be found by evaluating the definite integral

$$\int_{0.538}^{1.87} ((2x + 3 \sin x + 1) - (3x + 2)) dx = 0.525$$

- c. The volume of the region when we rotate it around the x -axis is given by

$$\pi \int_{0.538}^{1.87} ((2x + 3 \sin x + 1)^2 - (3x + 2)^2) dx = 19.4$$

- d. The volume of the region when we rotate it around the x -axis is given by

$$2\pi \int_{0.538}^{1.87} x((2x + 3 \sin x + 1) - (3x + 2)) dx = 4.01$$

fx-CG50

a.

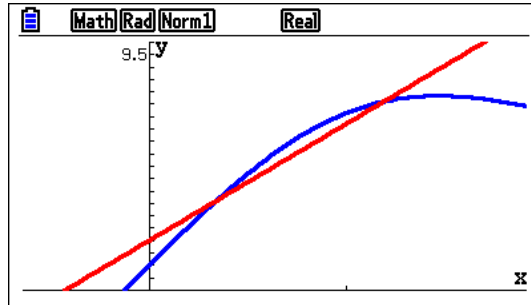

YY

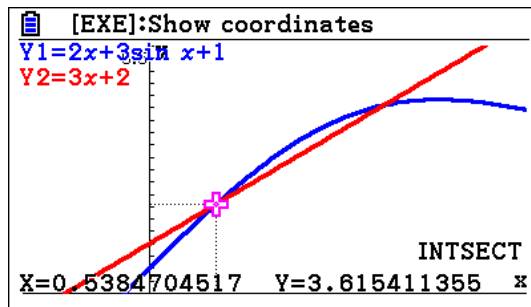

\$

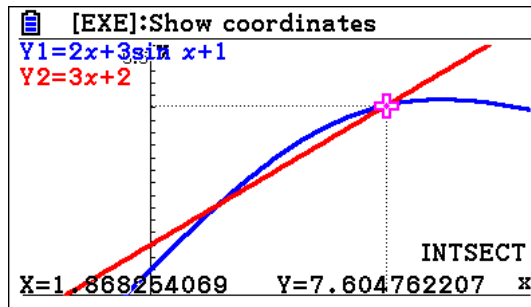

b. yuerthen use \$ as many times as it takes to reach the lower limit,1

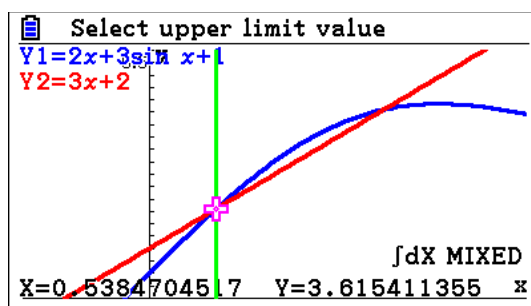

\$1

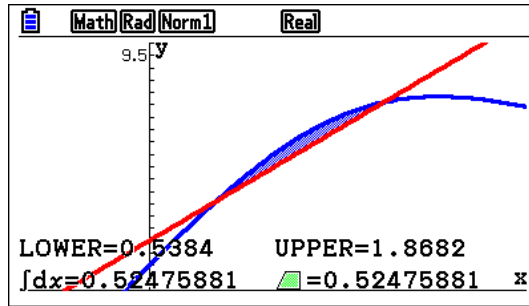

c. In the **Run-Matrix** app.

Press ruqC (or q1s- q2s)

\$0.538\$1.871

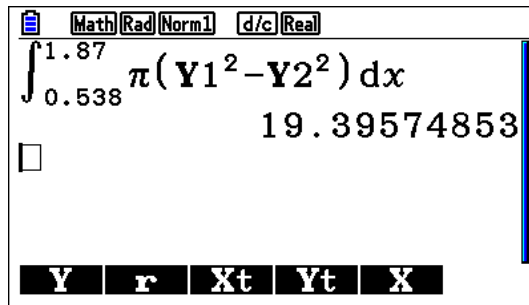

d. Again with a series of keys similar to the one above (we will leave this as an exercise for you) we have the value below.

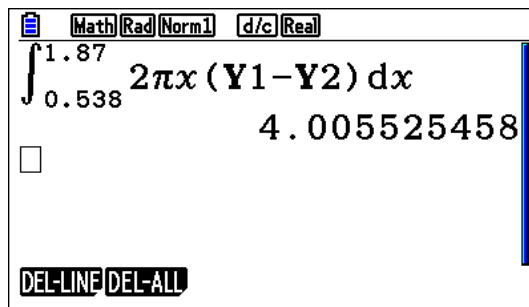

Example 11

Consider the function $f(x) = x(2x+3)^4$

- Solve the inequality $f(x) \geq 2x - 1$
- Find the area enclosed between the curve representing $f(x)$ and $y = 2x - 1$.

Exam response:

- for $f(x) \geq 2x - 1$ to be true, the graph of $f(x)$ must be above or equal to that of $y = 2x - 1$.

The two graphs intersect at three points whose x -coordinates are:

$-2.127, -0.831,$ and -0.0131 .

$f(x) \geq 2x - 1$ is true for all values of x such that

$$x \in [-2.127, -0.831] \cup [-0.0131, \infty[$$

- The area between the curves is

$$\int_{-2.127}^{-0.0131} |x(2x+3)^4 - 2x + 1| dx = 8.25$$

fx-CG50

- in **Graph** app. Enter the two functions and then Press γ for G-Solv. and then γ for intersection.

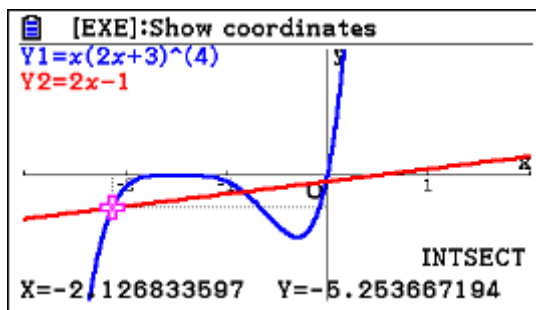

Then with $\$$ you get to the other points of intersection.

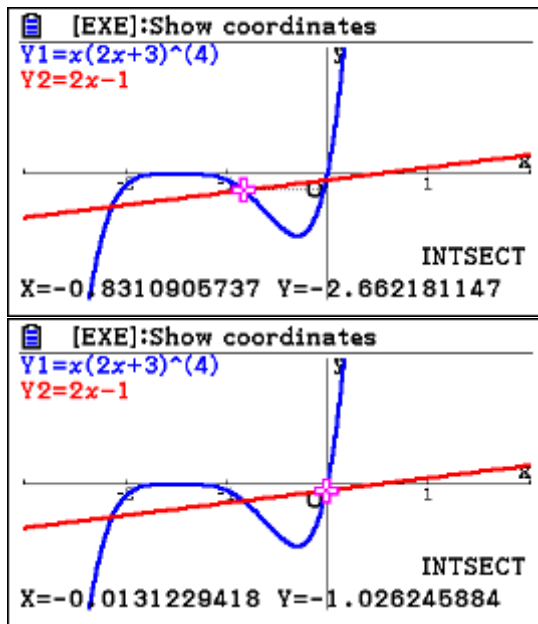

b. from the graph window

Press $\text{yuerl}\$ \$ \1

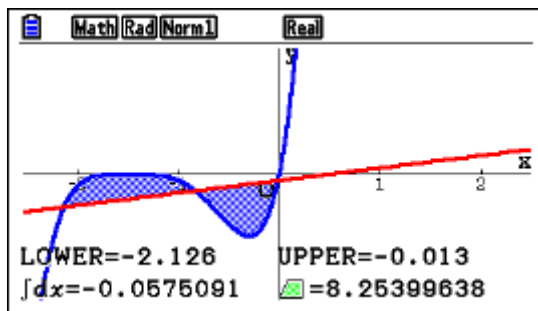

Example 12

The velocity of a particle in ms^{-1} is given by $v = e^{2\sin 2t} - 1$, for $0 \leq t \leq 5$.

- (a) Sketch the graph of v .
- (b) Write down the positive t -intercepts.
- (c)
 - (i) Find the acceleration when $t = 0$.
 - (ii) When is the acceleration the most?
- (d) Find the total displacement by the particle in the first five seconds.
- (e) Find the total distance travelled by the particle in the first five seconds

Exam response:

- a. here is a sketch

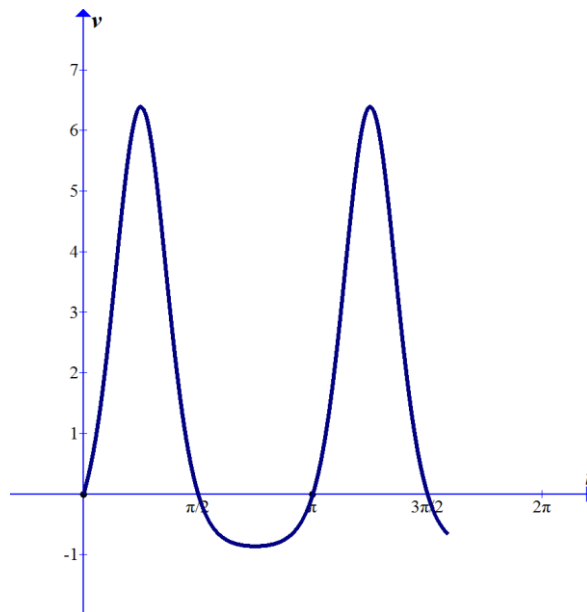

- b. The t -intercepts correspond to $v = 0$.

$$v = e^{2\sin 2t} - 1 = 0 \Rightarrow e^{2\sin 2t} = 1$$

$$\text{Thus } 2\sin 2t = 0 \text{ and hence } t \in \left\{0, \frac{\pi}{2}, \pi, \frac{3\pi}{2}\right\}.$$

c. The acceleration's value is the derivative of the velocity.

$$(i) \quad acc. = \frac{dv}{dt} = 4 \cos 2t e^{2 \sin 2t}$$

At time $t = 0$, $acc. = 4$

(ii) the acceleration is most at its maximum value or its minimum when it is negative.

From the graph of the acceleration function we can deduce that the maximum acceleration happens when $t = 0.448$ seconds or $t = 3.59$ seconds

Maximum deceleration when $t = 1.12$ seconds or $t = 4.26$ seconds.

d. Displacement is the difference between the final position and the starting position of the particle.

$$\text{Thus Displacement} = \int_0^5 v(t) dt = 8.96 m$$

e. Total distance is the sum of all displacements regardless of direction, hence

$$\text{Total Distance} = \int_0^5 |v(t)| dt = 11.3 m .$$

fx-CG50

a. In the **Graph** window, type the function expression in and **DRAW**.

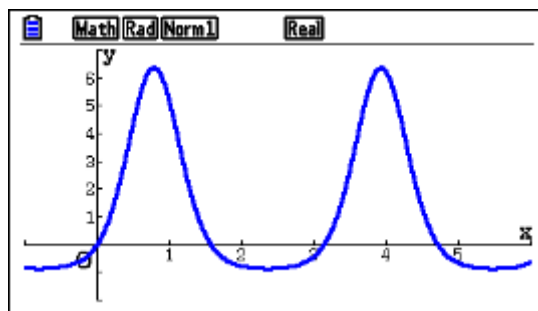

b. While in the graph window, press $\text{y}\square$, then repeatedly pressing $\text{\$}$ you will get the rest of the intercepts.

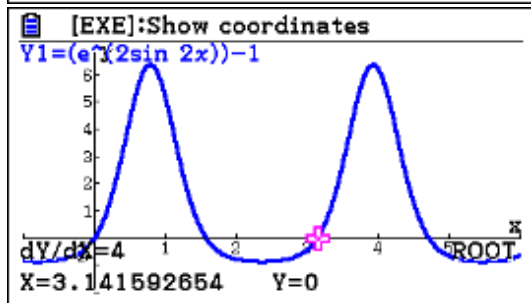
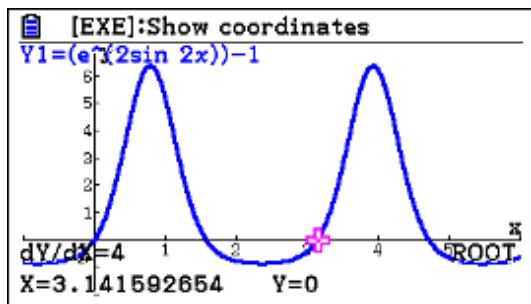
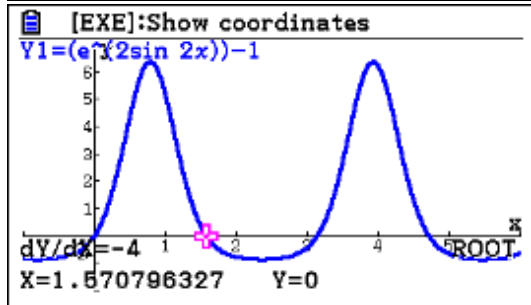
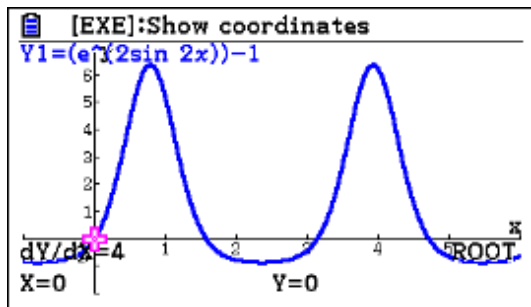

- c. (i) When you are in the **Graph Func** window

Press iwq

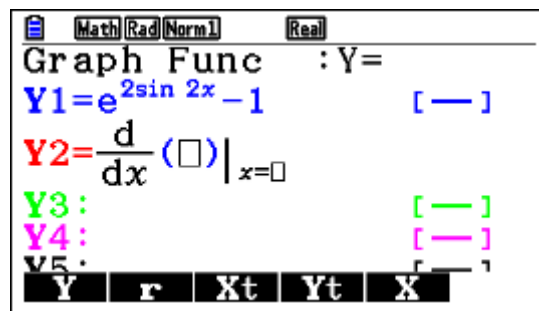

Now Press q1\$fl

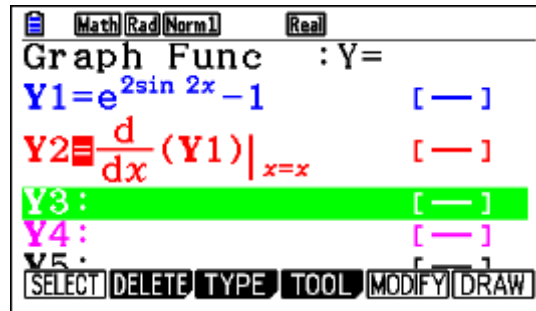

Press u to draw the graph of the acceleration.

To evaluate the function at any point, and in this case at $t = 0$, Press yuq01

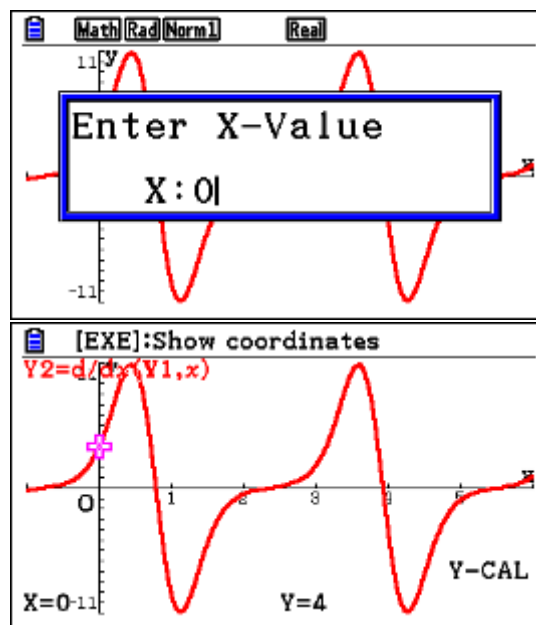

- (ii) To get the maximum acceleration/deceleration press yw to get to the maximum values

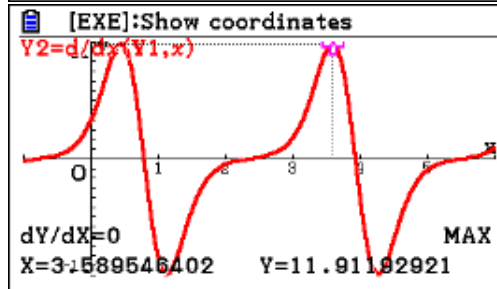
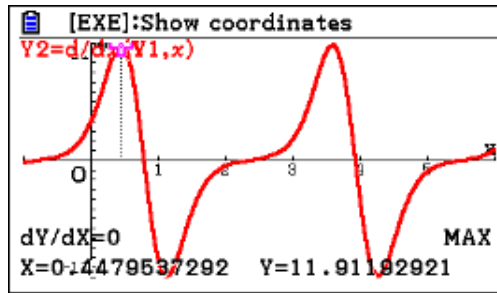

To get the largest deceleration, Press ∇

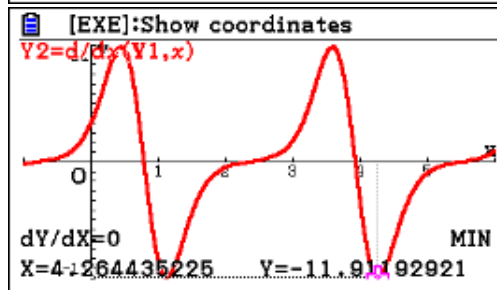
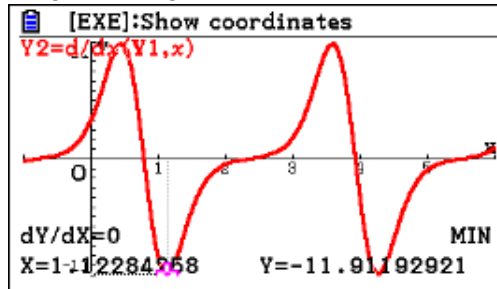

d. Go to **Run-Matrix** app.

Press \square

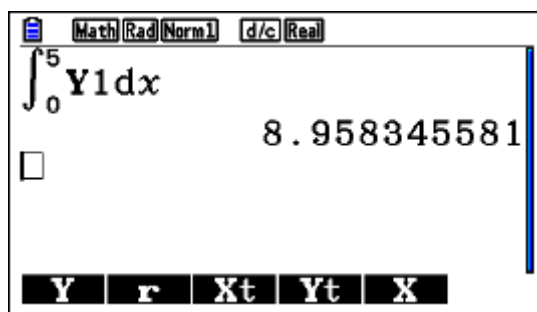

- e. Continue on the same screen and use arrows to place the cursor Y1 and delete it.
Now press reorq11

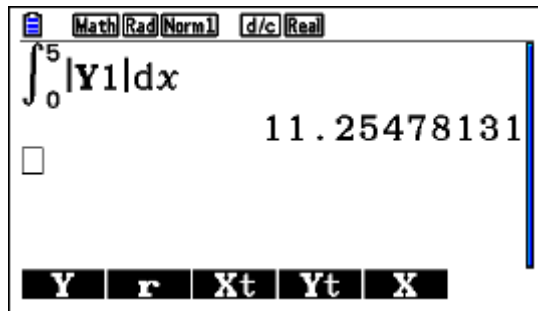

Example 13

The normal to the curve $y = x^2 - 4x$ at the point $(3, -3)$ intersects the x -axis at point P and the y -axis at point Q . Find the equation of the normal and the coordinates of P and Q .

Exam response:

The slope of the normal is the negative reciprocal of the value of the derivative at $x = 3$.

$$\text{Slope} = -\frac{1}{2x-4} = -\frac{1}{2}$$

$$\text{The equation of the normal is } y = -\frac{1}{2}(x-3) - 3 = -\frac{1}{2}x - \frac{3}{2}$$

$$\text{Thus } P(-3, 0) \text{ and } Q\left(0, -\frac{3}{2}\right)$$

fx-CG50

Go to **Graph** app. Type in the expression for the function

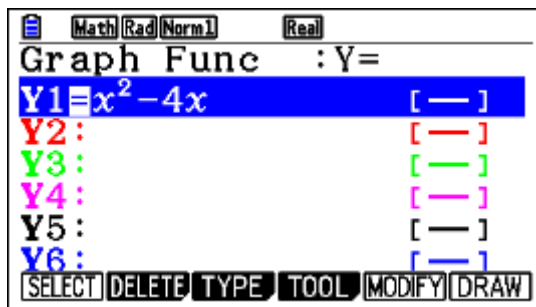

Press u to draw the graph, then r to sketch, e to choose the normal,

Now press 3 1

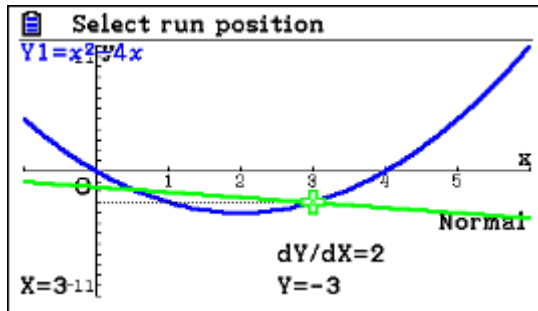

Press 1 again to get the equation of the normal

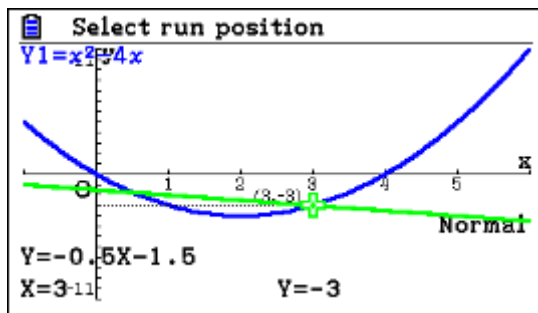

Simple substitution into the equation of the normal can give you the intercepts as requested.

Example 14

Sketch the graph of the function $f(x) = x^2e^x$ and label all extreme points and points of inflexion. Give your answer to 3 decimal places.

Exam response:

Here is a sketch of the graph the function $f(x) = x^2e^x$.

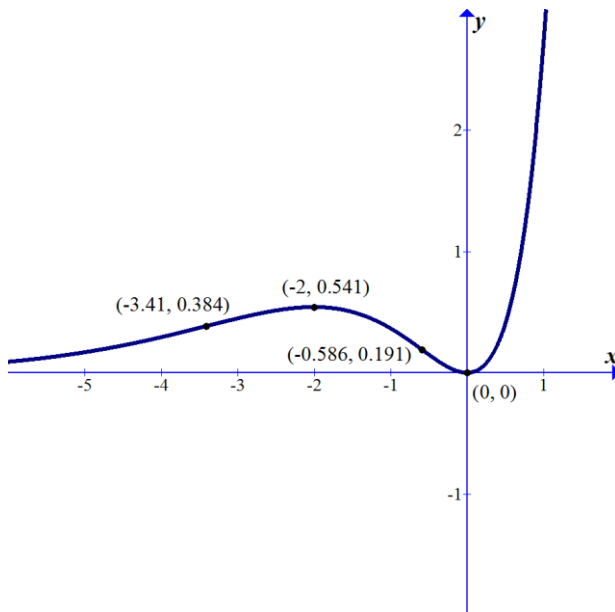

$$\frac{dy}{dx} = e^x(x^2 + 2x) \Rightarrow \frac{d^2y}{dx^2} = e^x(x^2 + 4x + 2)$$

Since $e^x > 0$, the first derivative is zero at $(0, 0)$ and $(-2, 0.541)$ while the second derivative is not zero. Hence these are extreme values. The second derivative changes signs and has zeros at $(-3.41, 0.384)$ and $(-0.586, 0.191)$ and hence these are the points of inflexion.

fx-CG50

In the **Graph** app., type the equation of $f(x)$.

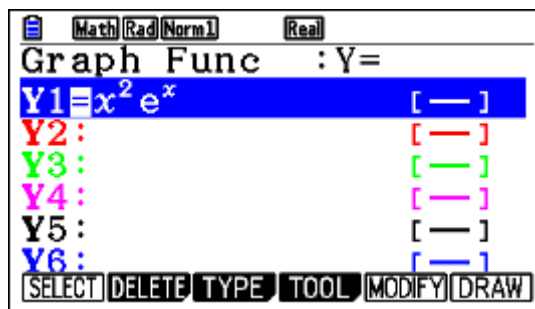

Press iwqq1\$fl

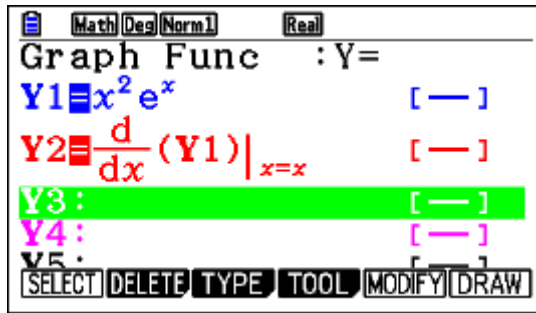

Press iwwq1\$fl

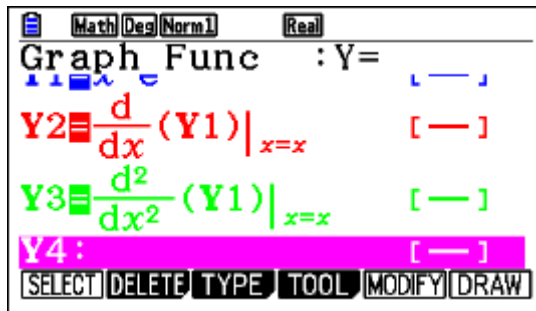

Now press u to get graphs of the function and its derivatives.

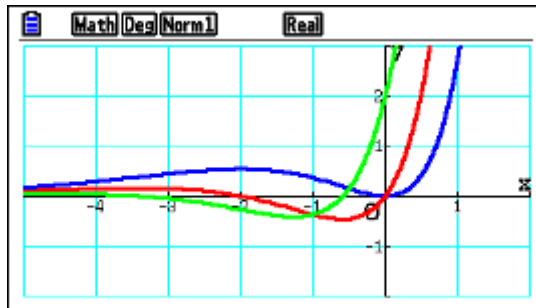

Press y to locate the extreme values.

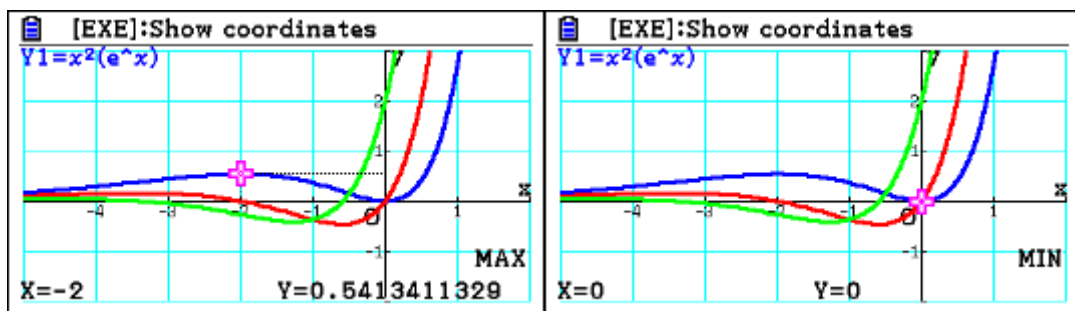

In order to locate the inflexion points, press yq to get to the zeros (Roots). Now press NN to get to the second derivative graph, press 1 to get to the first x-coordinate of a point of inflexion, press \$ to get to the second x-coordinate of a point of inflexion.

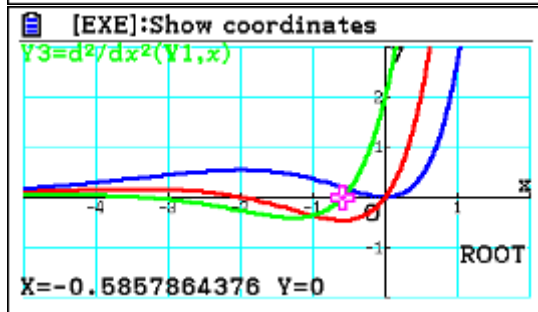
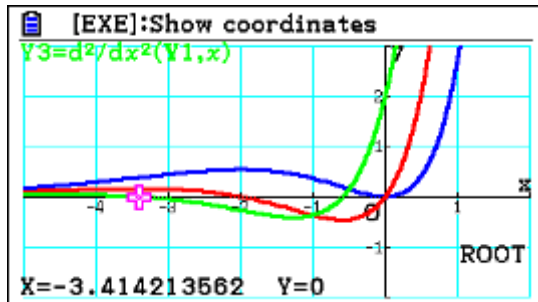

Now press `yuq1-3.411`

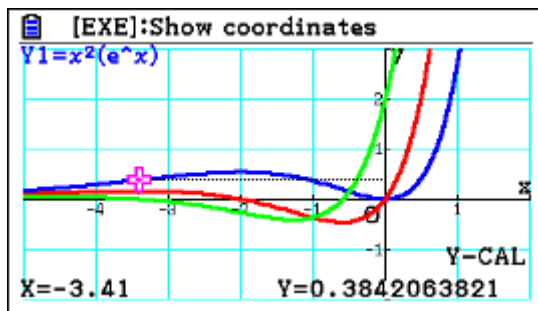

Similarly, press `yuq1-0.5861`

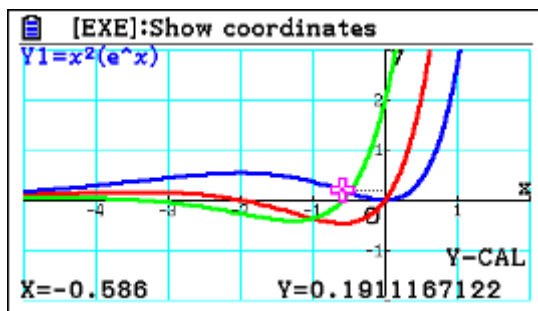

Example 15

A normal to the graph of $y = \arctan(x-1)$, for $x > 0$, has equation $y = -2x + c$, where $c \in \mathbb{R}$. Find the value of c .

Exam response:

Since the slope of the normal is -2 , the value of the derivative at the same point is 0.5 .

That is $\frac{1}{x^2 - 2x + 2} = \frac{1}{2} \Rightarrow x = 2 \Rightarrow y = \arctan(1) = \frac{\pi}{4}$, thus $c = 4 + \frac{\pi}{4}$

fx-CG50

In the **Graph** app., type in the equation, 1

Now press $\text{[i w q q 1] } \text{[f 1]}$

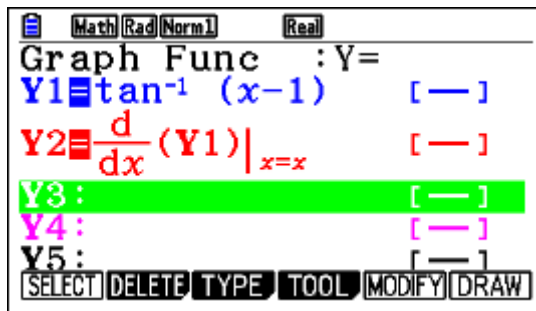

Press $\text{[u y u w N 1 0 . 5 1]}$

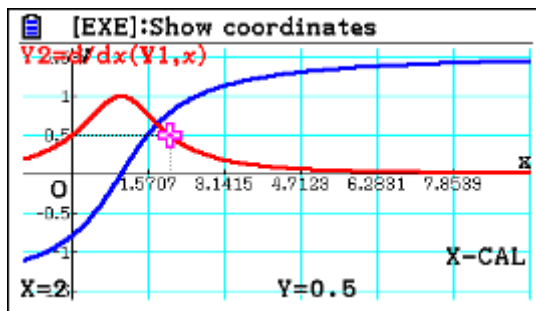

Now we know that the normal to the curve is at the point with x -coordinate of 2.

Press [r e 2 1 1]

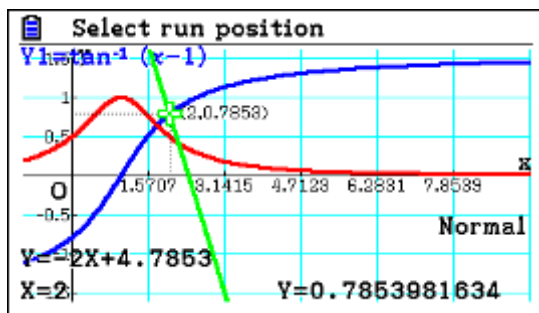

So, the value of $c = 4.79$.

Example 16

Let $f(x) = x \left(\sqrt[3]{(x^2 - 1)^2} \right), -1.4 \leq x \leq 1.4$.

- Sketch the graph of $f(x)$. On your graph indicate the approximate position of each zero and each extreme value.
- Find $f'(x)$, clearly stating its domain.
 - Find the x -coordinates of the extreme points of $f(x)$ for $-1 < x < 1$.
- Find the x -coordinate of the point of inflexion of $f(x)$, giving your answer correct to four decimal places.

Exam response:

- Here is a sketch of the graph of the given function

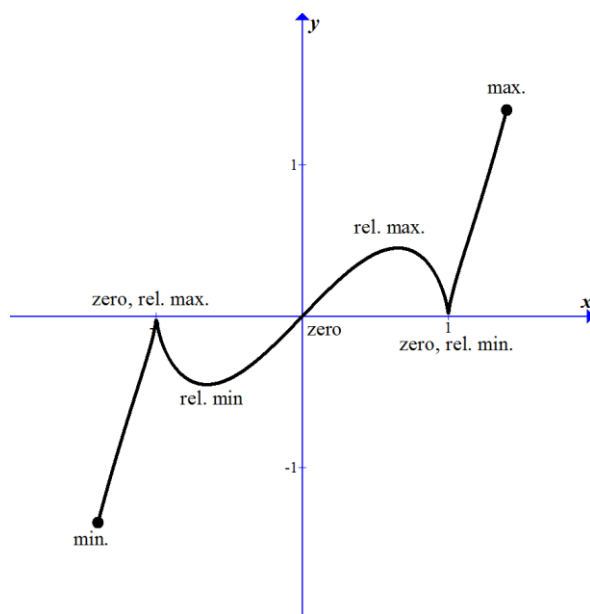

b) i.
$$f'(x) = \frac{\sqrt[3]{(x^2-1)^2}}{\sqrt[3]{x^2-1}} + \frac{4x^2}{3\sqrt[3]{x^2-1}} = \frac{7x^2-3}{3\sqrt[3]{x^2-1}}$$

Domain: $[-1.4, -1[\cup]-1, 1[\cup]1, 1.4]$

ii.
$$f'(x) = \frac{7x^2-3}{3\sqrt[3]{x^2-1}} = 0 \Rightarrow x = \pm\sqrt{\frac{3}{7}} \approx \pm 0.6547$$

c) The x -coordinates of the points of inflection correspond to the values when the second derivative is zero.

The values are: $x = -1.1339$, $x = 0$, or $x = 1.1339$.

fx-CG50

a) b) In the **Graph** app. enter the equation as usual.

Press \square to draw. (don't forget to adjust the viewing window)

Now press \square and then \square for the maximum, and then $\$$ to locate the maximum

in $]-1, 1[$.

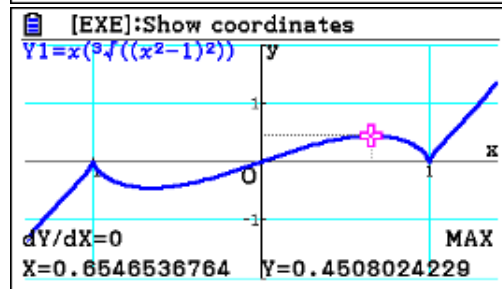
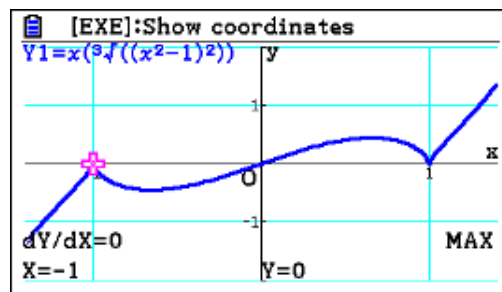

Do the same for the minimum: \square

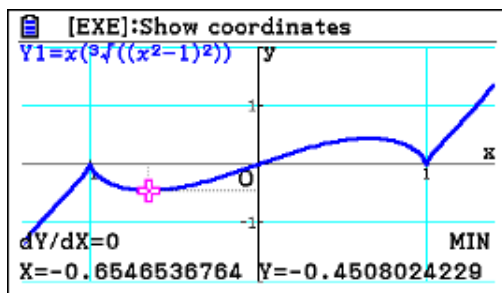

c) In the **Graph Func** window, press \square , then \square

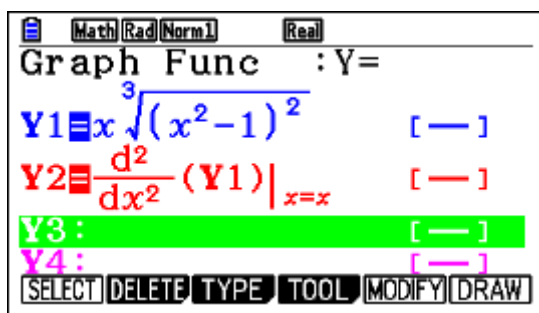

Now \square to draw and then \square

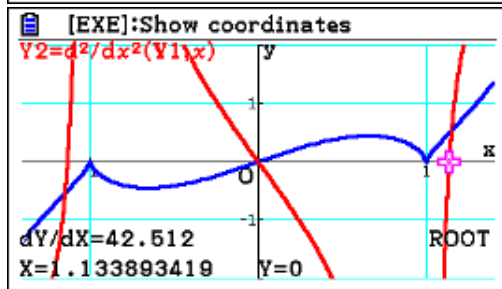
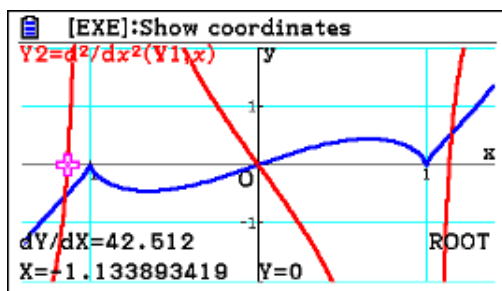

0 is obviously another value.

Example 17

Let $f(x) = \frac{2x-3}{x+2}; x \neq -2$

- (a) Find $f^{-1}(x)$
- (b) (i) Sketch the graph of f for $-8 \leq x \leq 8$, and $-5 \leq y \leq 7$, including any asymptotes.
- (ii) Write down the equations of the asymptotes as well as the x - and y -intercepts of the graph of f .
- (c) (i) Find the value of $\int_0^5 f(x) dx$
- (ii) Find the area of the region (R) enclosed by $f(x)$ and the x -axis between $x = 0$ and $x = 5$.
- (iii) Find the volume when R is revolved through 360° about the x -axis.

Exam response:

- (a) $y = \frac{2x-3}{x+2}$ we solve for x and then switch the variable names,

$$\text{Thus } xy + 2y = 2x - 3 \Rightarrow y = f^{-1}(x) = \frac{2x+3}{2-x}$$

- (b) (i) Here is a sketch

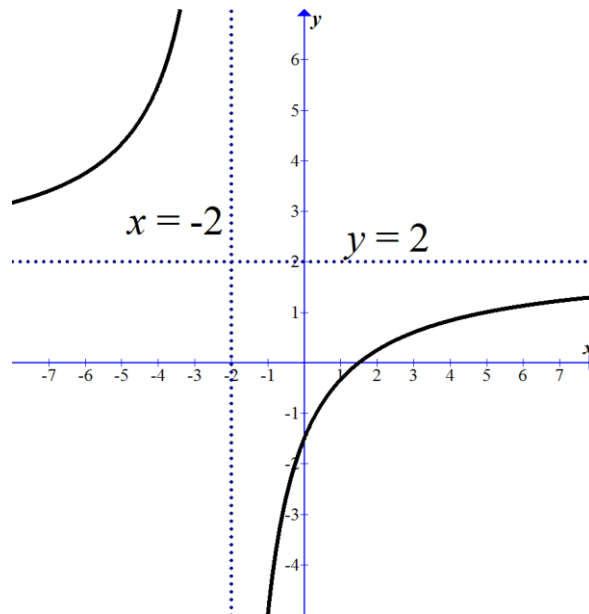

- (ii) x -intercept: (1.5, 0)
 y -intercept: (0, -1.5)
horizontal Asymptote: $y = 2$, vertical asymptote: $x = -2$

(c) (i) $\int_0^5 f(x) dx = \int_0^5 \frac{2x-3}{x+2} dx = 1.23$

- (ii) Since the graph intersects the x -axis between 0 and 5, we need to find the integral of the absolute value of the integrand (alternatively, divide the interval into two and add the absolute values)

$$\text{Area} = \int_0^5 \left| \frac{2x-3}{x+2} \right| dx = 3.07$$

(iii) $\text{Volume} = \pi \int_0^5 (f(x))^2 dx = \pi \int_0^5 \left(\frac{2x-3}{x+2} \right)^2 dx = 7.61$

fx-CG50

- (a) This is a non-gdc part. However, *fx-CG50* can confirm the result.
Graph $f(x)$ and $f^{-1}(x)$

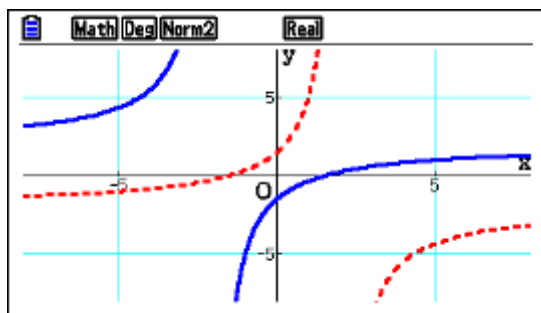

Notice that we chose the graph of $f^{-1}(x)$ to be in dots. Now, go to **Sketch** and graph the inverse.

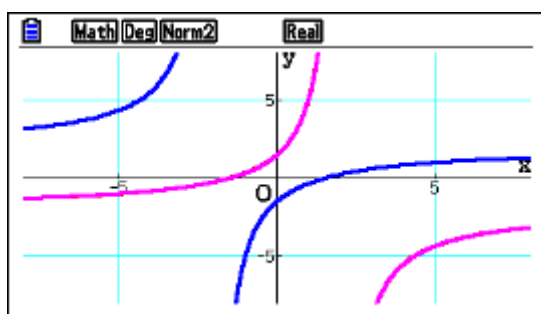

As you can see the inverse is drawn on top of $f^{-1}(x)$.

b. (i, ii)

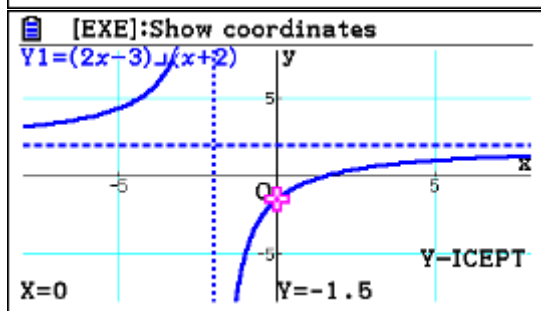
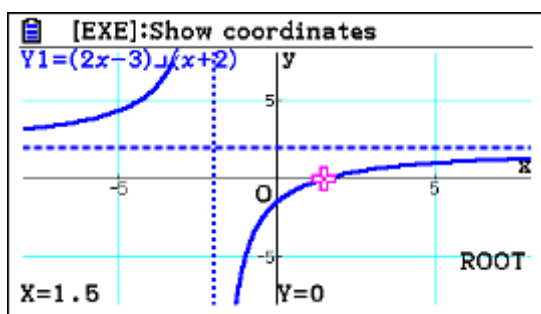
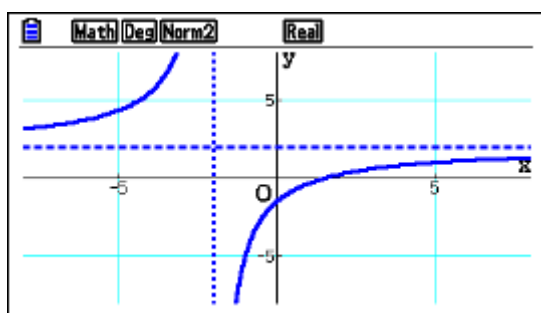

- (c) (i) From the graph window we press yueq then type 0 followed by 1 and 5 followed by 1

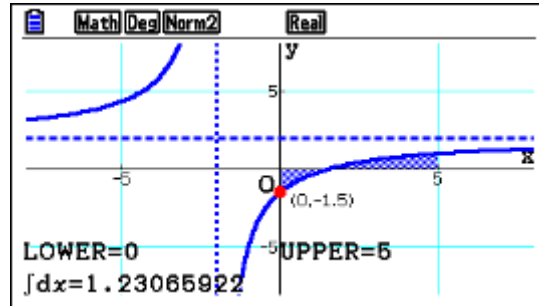

- (ii) Choose another Y and enter $|Y1|$ (in Graph window: d, choose Y5 and press iyqlu
Now $\text{yueq}0151$

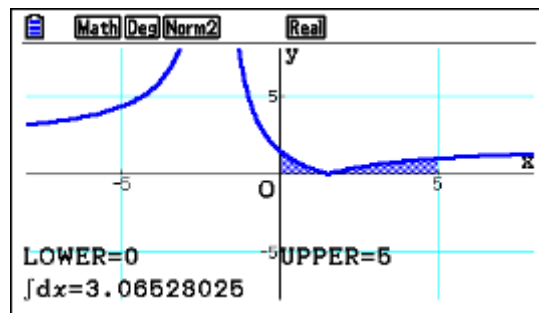

- (iii) Same as above, but enter $\pi|Y1|^2$ into Y5.

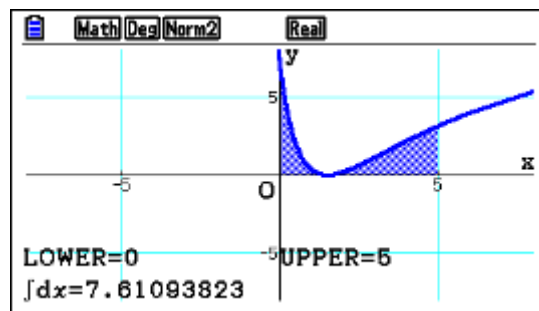

Example 18

The line $y = 16x - 9$ is tangent to the curve $y = 2x^3 + ax^2 + bx - 9$ at the point $(1, 7)$. Find the values of a and b .

Exam response:

If the line is tangent to the curve at $(1, 7)$, then the slopes are equal at that point:

$$6x^2 + 2ax + b = 16, \text{ that is } 2a + b = 10$$

The point $(1, 7)$ is on the curve, $2 + a + b - 9 = 7$, that is $a + b = 14$

Solving the system of equations: $a = -4, b = 18$.

fx-CG50

This last exercise is meant as an example to demonstrate that the gcd does not always offer the best solution.

Chapter 4

Probability-Statistics

This chapter will discuss exercises and problems related to probability and statistics topics including descriptive statistics, graphs, combinatorics, probability distribution functions, and inferential statistics. It will cover the HL, SL, and Math Studies topics.

It is very important to keep in mind in dealing with questions of this type is that the *fx-CG50* can perform most of the procedures required by the IB syllabi. This is why you should always focus on showing some work leading to your results and on interpreting your results in the context of the question at hand.



To get to the **Statistics** app., you start at the main menu and scroll to **Statistics** and press 1.

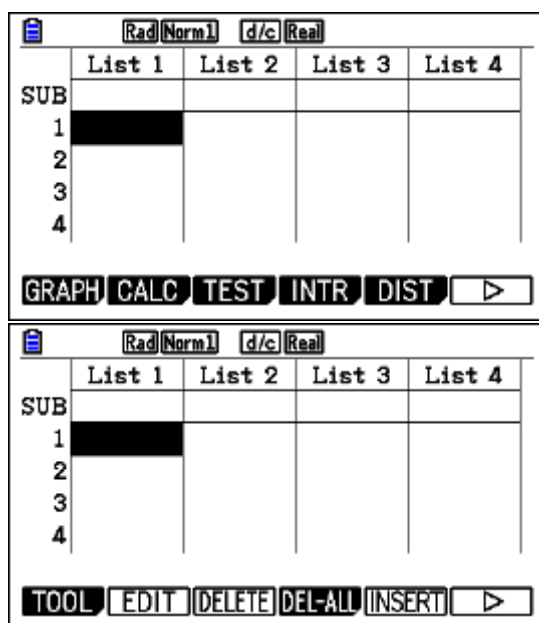

As you notice, you can enter data in lists. Once data is entered, the submenus give you the possibilities to graph, get descriptive statistics, run tests and find confidence intervals, calculate probabilities in probability distributions included in IB syllabi and more, and manage your data lists.

We will start with a general example demonstrating some of the *fx-CG50*'s features and then proceed to exam-type questions.

Example

Here are the total scores of students in a large school on their IB exams during the May session 2015.

Score	23-25	26-28	29-31	32-34	35-37	38-40	41-43
Students	5	17	23	37	19	15	4

One way of dealing with data grouped in classes like this is to represent each class by its “class mid-point”. For example 23-25 will be represented by 24.

The top cell in each list is reserved for the name of the list if you wish – you can continue calling it List 1, List 2, etc. You reach this cell by pressing B

To type the numbers in, you simply enter the numbers followed by 1.

Here is the first entry 241

	List 1	List 2	List 3	List 4
SUB	GRADE	STUDEN		
1	24	5		
2	27	17		
3	30	23		
4	33	37		

We will start by drawing a *histogram* of the data.

First press u to “SET” the type of graph. Now press uq to get the histogram

Then scroll down N to specify where your data is,

Press q to choose LIST and you get to specify which one you want. 1 in this case.

```

StatGraph1
Graph Type : Histogram
[X] Select List No.
Fr
Co List[1~26]: 1
Hist Area : Blue/L
HistBorder : Black
LIST
  
```

We also stored frequency in LIST2.

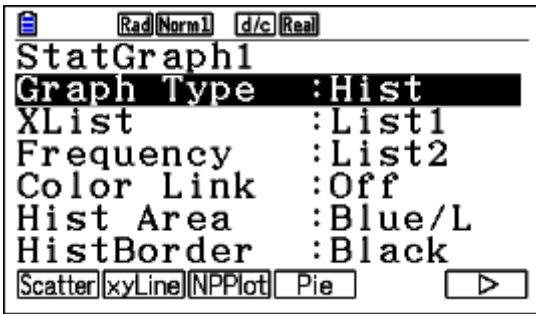

Now press 1 which will take you back to the List screen. Press \square to get to GRAPH1

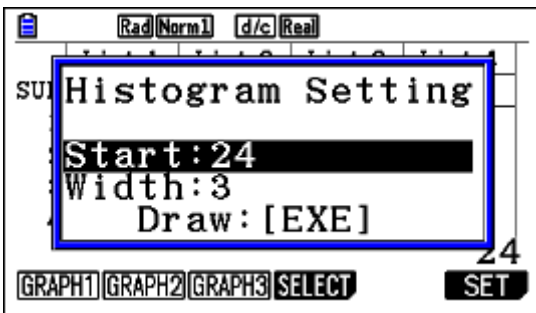

Type in the first limit and the class width followed by 1

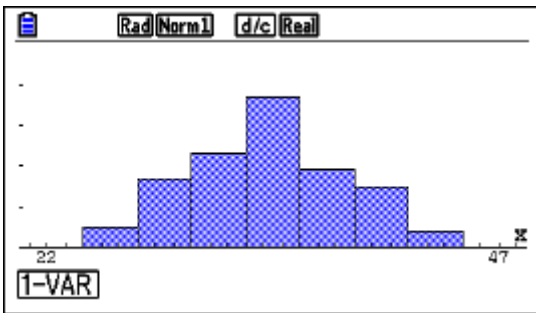

When you press \square you also get the basic descriptive statistics of the data

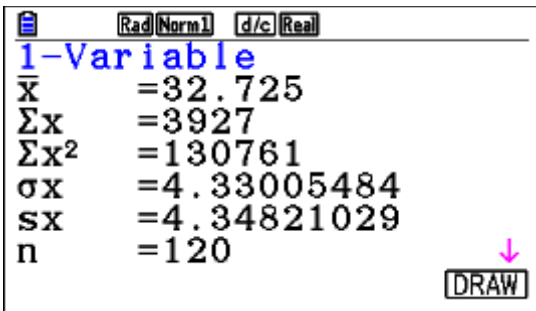

If you are not interested in drawing the histogram and you need the descriptive statistics of the data only, you can do that from the List screen by pressing w

		List 1	List 2	List 3	List 4
SUB	GRADE	STUDEN			
1	24	5			
2	27	17			
3	30	23			
4	33	37			
					24

GRAPH CALC TEST INTR DIST ▶

		List 1	List 2	List 3	List 4
SUB	GRADE	STUDEN			
1	24	5			
2	27	17			
3	30	23			
4	33	37			
					24

1-VAR 2-VAR REG SET

Now by pressing \square you can specify the parameters of your data.

On this screen press \square to choose your lists.

		List 1	List 2	List 3	List 4
1Var	XList	:List1			
1Var	Freq	:List2			
2Var	XList	:List1			
2Var	YList	:List2			
2Var	Freq	:1			

LIST

If your data is raw data (listed here in LIST3) – that is not grouped, then you can specify your graphs as follows:

Press \square for SET, then \square for GRAPH2, then scroll down changing the parameters as you wish.

		List 1	List 2	List 3	List 4
StatGraph2	Graph Type	:Hist			
	XList	:List3			
	Frequency	:1			
	Color Link	:Off			
	Hist Area	:Blue/L			
	HistBorder	:Black			

COLOR

Now press \square for GRAPH2 and specify the starting point and the width

		List 1	List 2	List 3	List 4
SUB	GRADE	STUDEN			
1	24	5			
2	27	17			
3	30	23			
4	33	37			
					24

Histogram Setting

Start: 23

Width: 3

Draw: [EXE]

GRAPH1 GRAPH2 GRAPH3 SELECT SET

Press \square

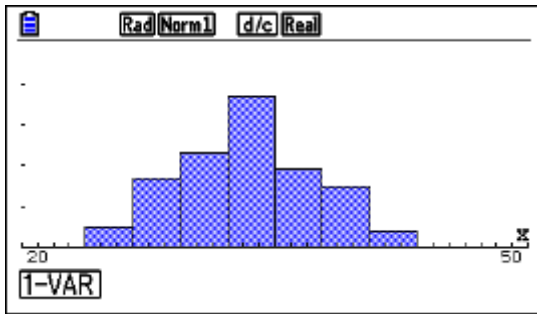

Considering the data as a random sample of a large population of students in the May 2015 session, and suppose we want to use this data to test the hypothesis that the average score is more than 30.

The hypotheses we have are then:

$$H_0 : \mu \leq 30$$

$$H_1 : \mu > 30$$

As the data is our only source of information, we will use the t -test.

From the **Statistics** app. window press ϵ then w for the t -test.

Press α for 1-sample t -test.

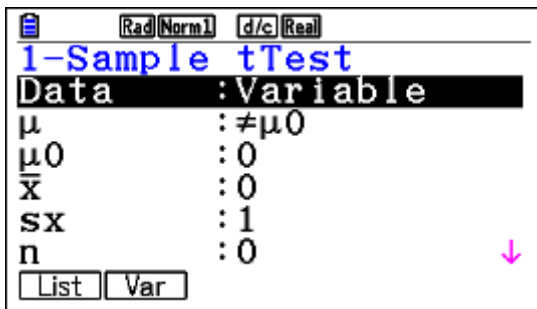

You either choose Var. and enter the sample statistics manually, or choose List to use the data stored in a list. We will use List first. Press α NeN301Nq311

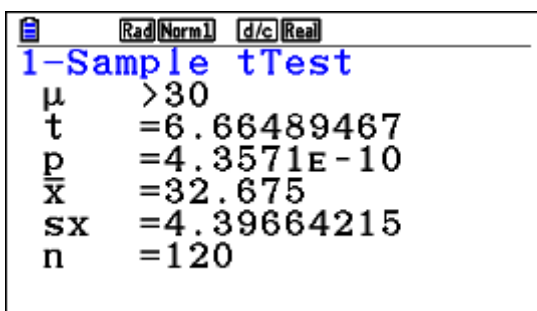

Since the p -value is almost 0, we reject H_0 and conclude that we have enough evidence to claim that the average score of the population of students is more than 30.

If we choose to use our descriptive statistics results of this sample, then we can use the following steps

From the **Statistics** app. window and after pressing ϵ then w for the t -test, and pressing q for 1-sample t -test, we get

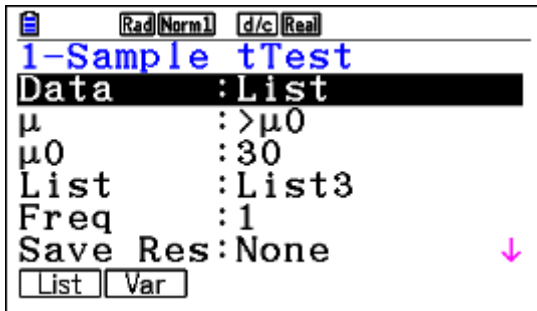

Press w to choose Var, then

Press $N \rightarrow 30132.67511.397112011$

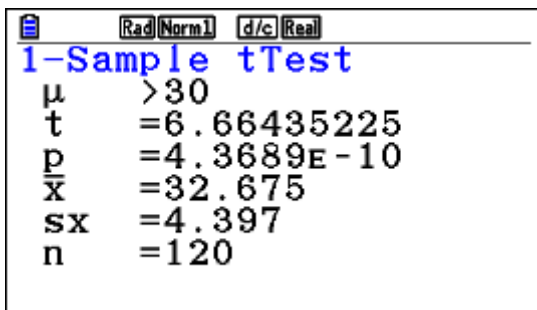

Finding a *confidence interval* can also be performed nicely with the *fx-CG50*. Suppose we want to use the data at hand to set up a 90% confidence interval for the average score of the large student population mentioned above.

From the main List-screen press r (INTR), then w for a t -interval, then q for a 1-sample.

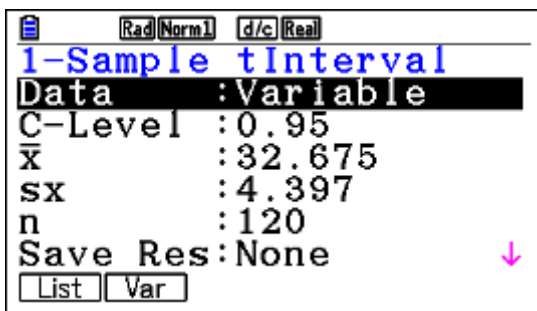

Again we have a choice of sample data (List) or sample statistics (Var). We will demonstrate both.

Press q for List, $N \rightarrow .901q31NNN1$ (Instead of 1 you can press q too)

```
Rad Norm1 d/c Real
1-Sample tInterval
Lower=32.0096472
Upper=33.3403528
x̄ =32.675
sx =4.39664215
n =120
```

Thus we are 90% confident that the mean is between 32.010 and 33.340.

Using the sample statistics below will also give the same result.

Press w for Var, NO.90132.67515.39711201N1 (Instead of 1 you can press q too)

```
Rad Norm1 d/c Real
1-Sample tInterval
Lower=32.0095931
Upper=33.3404069
x̄ =32.675
sx =4.397
n =120
```

IB Question Types

We will start with a basic example from Math Studies to show the use of the calculator for some typical IB questions. As always, we do not advocate depending solely on the calculator to form our mathematical findings – you will see in the examples below that it will not do everything for you nor will it be faster than you all the time!

The first four examples are for Math Studies students. The rest are either Math SL or Math HL + Option 7.

Example 1

Consider the frequency histogram for the distribution of the duration, t , in minutes of meeting times that Kevin made last week.

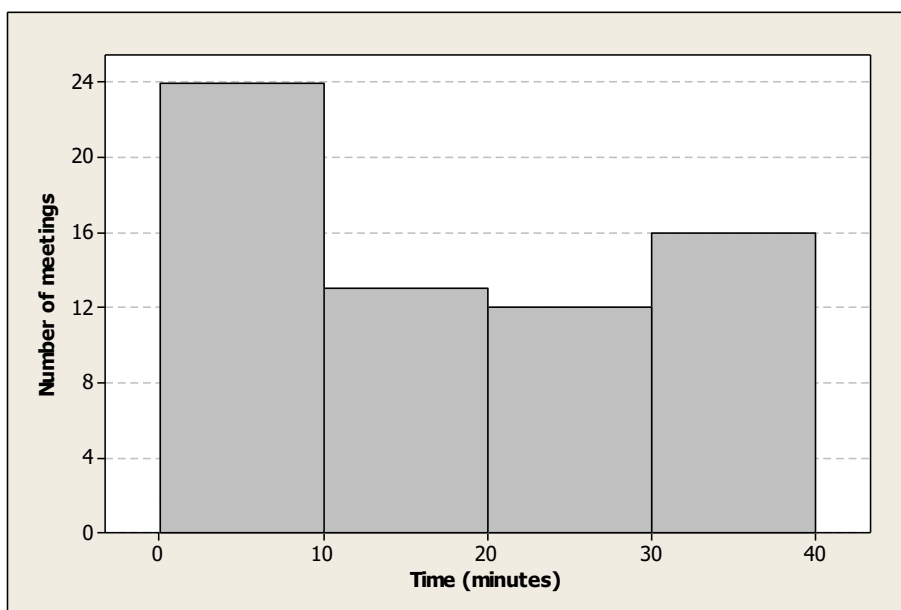

- (a) Complete the frequency table for this distribution.

Time (min.)	Number of meetings
$0 \leq t < 10$	
$10 \leq t < 20$	
$20 \leq t < 30$	
$30 \leq t \leq 40$	

- (b) Write down the modal class.
(c) Find an estimate for the mean time.

Exam response:

(a)

Time (min.)	Number of meetings
$0 \leq t < 10$	24
$10 \leq t < 20$	13
$20 \leq t < 30$	12
$30 \leq t \leq 40$	16

(b) The modal class is $0 \leq t < 10$.

(c) Each class will be represented by its midpoint. So an estimate of the mean is

$$\bar{x} = \frac{\sum x_i}{n} \approx 18.077$$

X_i is the midpoint of the i th class.

fx-CG50

(a), (b) These two parts are non-gdc

(c) Enter the data (List 4 & 5)

	List 4	List 5	List 6	List 7
SUB				
TIME		MEETIN		
1	5	24		
2	15	13		
3	25	12		
4	35	16		

Press wu, then press q4 to enter List4, Nw5

Mode	Setting
1Var	XList : List4
1Var	Freq : List5
2Var	XList : List1
2Var	YList : List2
2Var	Freq : 1

Now press 1 q

1-Variable	
\bar{x}	=18.076923
Σx	=1175
Σx^2	=30625
σx	=12.0157687
sx	=12.109278
n	=65

Example 2

The following data are for the age(in years) of 8 randomly chosen children and how fast they could run (in km/hr).

Age: x	2	4	7	12	4	8	9	2
Speed: y	5	8	12	24	12	14	18	7

- Draw a scatter diagram of the data
- Write down the coordinates of the mean point (\bar{x}, \bar{y}) .
- Write down the value of r , the Pearson's product-moment correlation and interpret it.
- Write down the regression equation and draw the line on your scatterplot.

Exam response:

- Here is a scatter diagram of the data with Age on the horizontal axis and speed on the vertical axis. The diagram shows

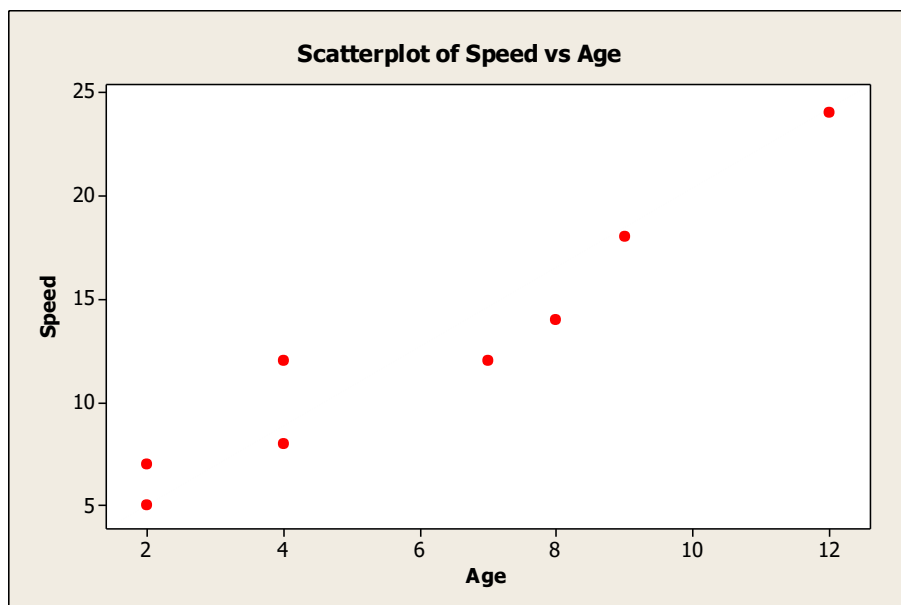

- b. The mean point $(\bar{x}, \bar{y}) = (6, 12.5)$
- c. $r = 0.959$. This indicates a strong positive association between Age and Speed.
- d. The regression equation is:
Speed = 1.667 Age + 2.5

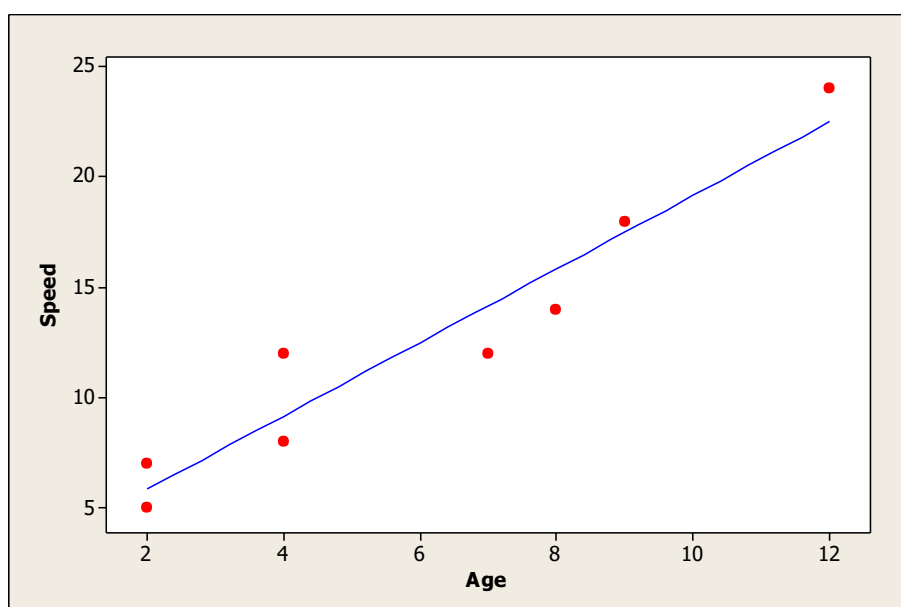

fx-CG50

- a. Enter data into List 1 and List 2

Press \square for GRAPH, then \square for SET, \square \square \square \square \square \square \square \square

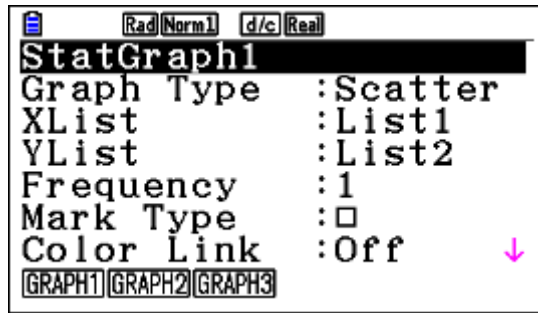

Note: You need to set Frequency to 1 before you continue!

Now press \square

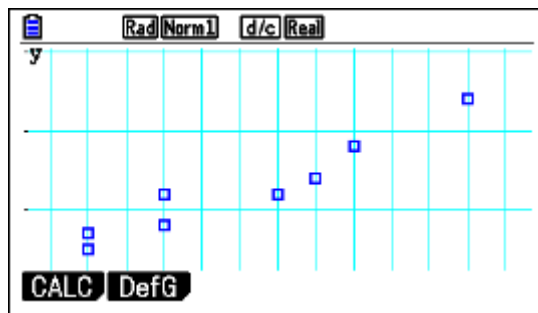

b. While in the Graph window, press \square

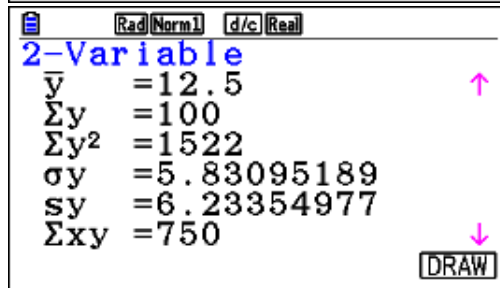
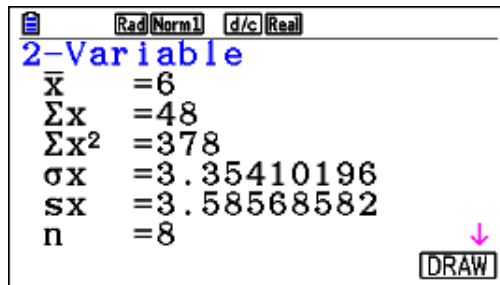

c, d. From the lists screen, press \square \square (wis also fine)

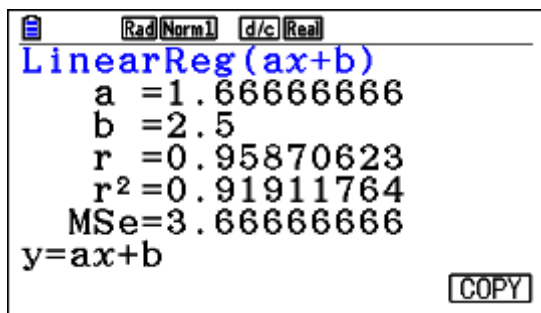

Now press \square to copy the result, choose an empty Y and press 1.

From the list window, press \square for GRAPH and \square again followed by \square

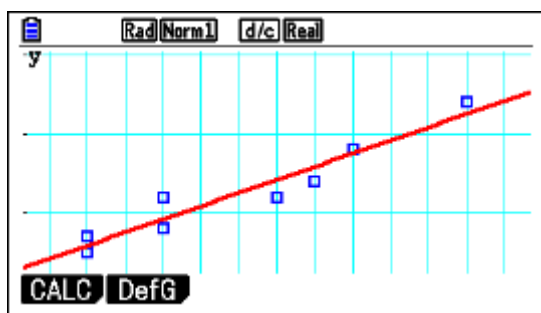

Example 3

Students at a certain school choose to register for one of three mathematics exams, HL, SL, or M. Studies. The number of students of each gender choosing each exam in a particular year is shown in the table below.

A χ^2 (Chi-squared) test at the 5 % significance level is used to determine whether the choice of exam is independent of gender.

	HL	SL	M. Studies
Male	80	40	20
Female	40	30	30

- Find the expected number of female SL students under this hypothesis.
- Write down the p-value for the test.
- State, with a reason, the conclusion of the test.

Exam response:

- a. Expected number of female students = $\frac{100 \times 70}{240} \approx 29.2$
- b. p -value = 0.00556
- c. The test is to determine whether H_0 : Choice of exam and gender are independent can be rejected.

Because the p -value of 0.00556 < 5%, we have enough evidence to reject H_0 . Thus we can conclude that we have enough evidence to say that gender and choice of exams are not independent.

fx-CG50

For all parts, we need to run the χ^2 test.

First, we need to store our observed data in a matrix.

We go to **Run-Matrix** app.

Press \square then choose a matrix, A in this example (any other matrix is fine), press \square to choose the dimensions, 2 1 3 1

Type in the numbers followed by 1 each

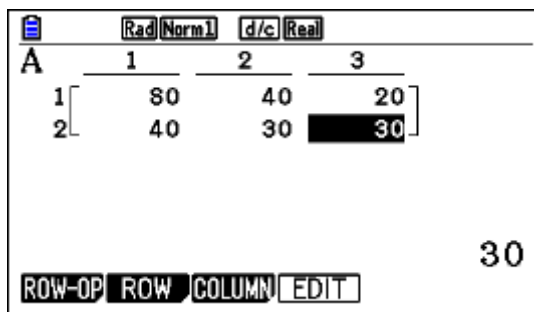

Now go the **Statistics** app.

Press \square for **TEST** and \square again to get to the Chi Squared test. \square to get to the independence test (2WAY).



Having stored the data in matrix A, you don't need to change it. However, if you have stored it in a different matrix, then you need to change it here too.

Scroll down to **Execute** and press \square or 1

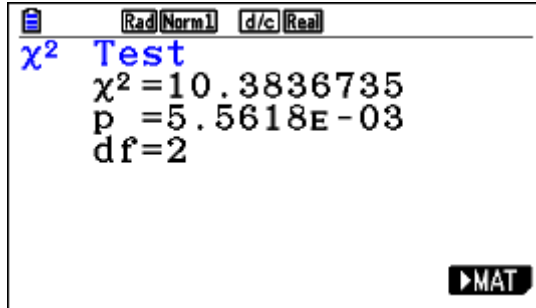

Press \square

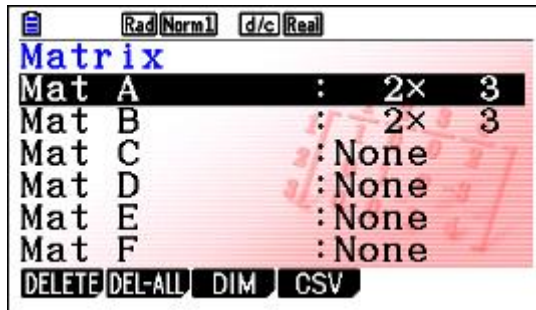

Press \square

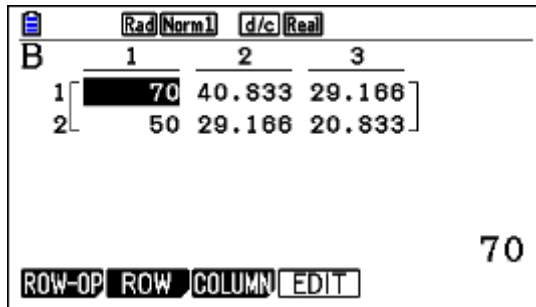

Example 4

The heights of 100 students at a certain school are listed in the table below.

Height (cm)	Number
172	12
176	26
180	32
184	21
188	9

- find the mean height
- find the standard deviation
- find the median
- find the interquartile range
- draw a box and whisker diagram for this data using a scale of 1 cm to represent 2 cm.

Exam response:

- The mean height: $\bar{x} = 179.56$ cm
- The standard deviation is 4.56 cm
- The median is 180 cm
- Interquartile range = $Q3 - Q1 = 184 - 176 = 8$ cm
- (to be done manually!)

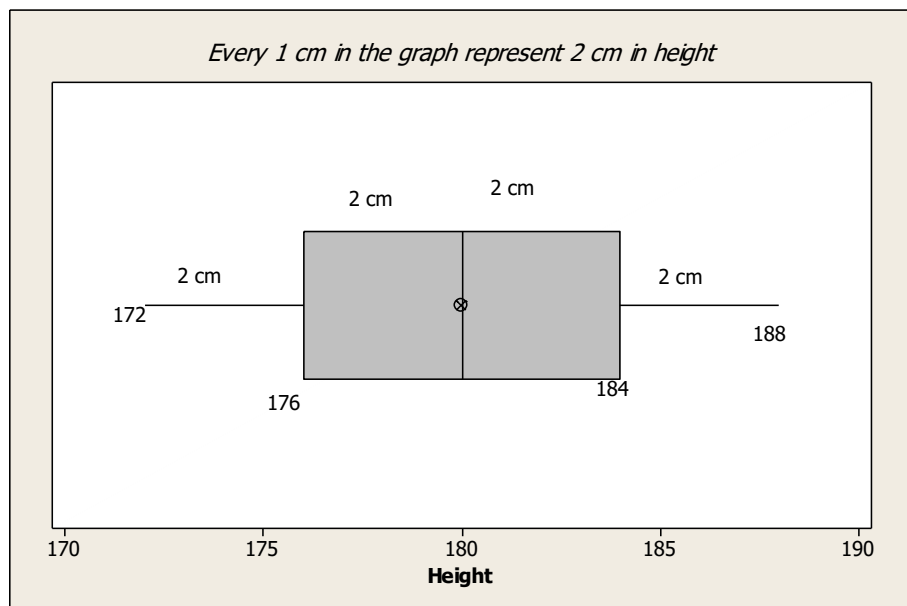

fx-CG50

From the main menu, go to **Statistics**.

Enter data as shown below.

	List 1	List 2	List 3	List 4
SUB	Height	Number		
1	172	12		
2	176	26		
3	180	32		
4	184	21		

172

GRAPH CALC TEST INTR DIST >

Press \square , scroll down to Graph Type \square , make sure that XList is List1 and Frequency is List2

	List 1	List 2	List 3	List 4
SUB	Height	Number		
1	172	12		
2	176	26		
3	180	32		
4	184	21		

StatGraph1

Graph Type : MedBox

XList : List1

Frequency : List2

Outliers : Off

Box : Black

Whisker : Black

GRAPH1 GRAPH2 GRAPH3

Press \square

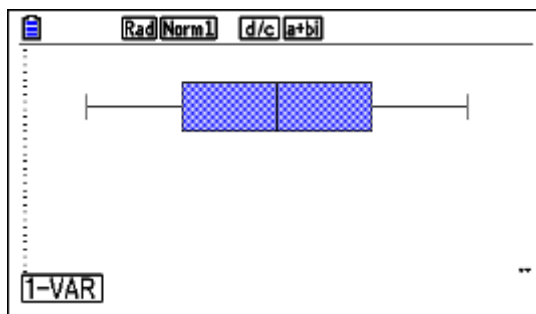

Press \square and scroll N to get all the info.

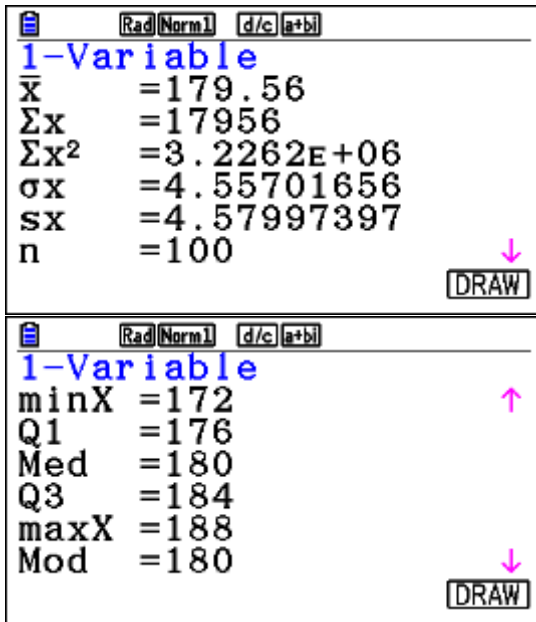

Press uLq to trace

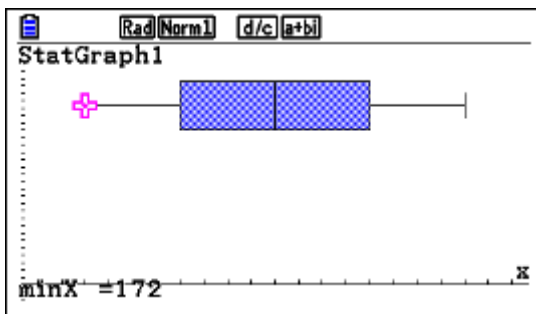

As you scroll right with \$ you will get the other values

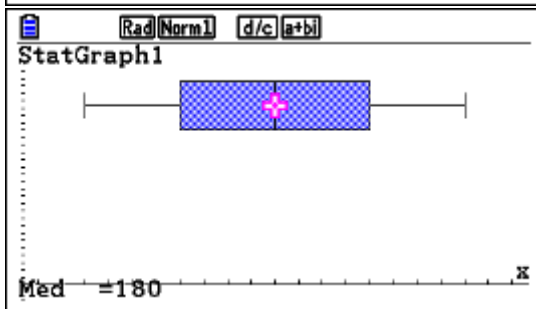
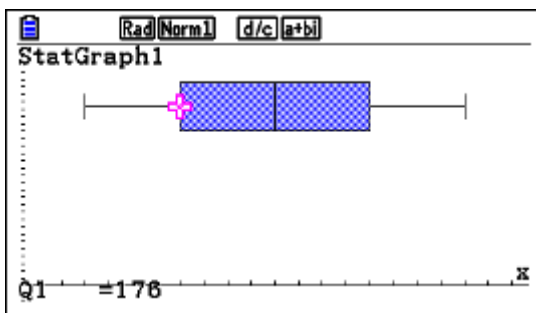

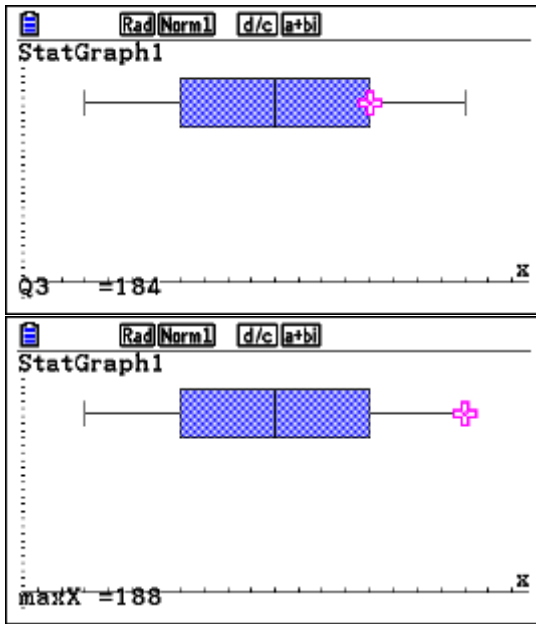

Example 5

What is the number of ways in which eleven different books can be given to three students, if the youngest is to receive five books and the others receive three books each.

Exam response:

There are $\binom{11}{5}$ ways of giving the youngest student 5 books.

The rest of the books are 6, and there are $\binom{6}{3}$ ways of giving the books to one of the other two, the rest will automatically go to the third student.

Therefore the number of ways 11 books will be distributed to the three students is

$$\binom{11}{5} \binom{6}{3} = 9240$$

fx-CG50

From the main menu, go to **Run-Matrix** app.

Press `iu11ee5m6e3l`

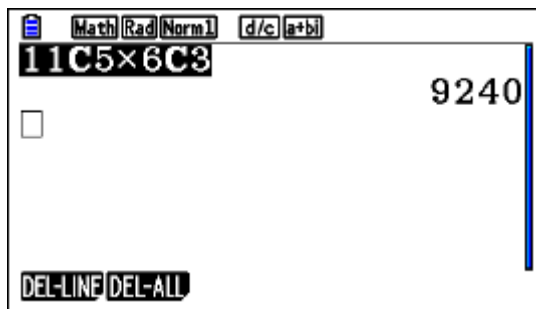

Example 6

You took part in a standardized test. The scores on this test follow a normal distribution with mean 200. You scored 248 points and your ranking is at the 80th percentile.

Calculate the variance of the distribution.

Exam response:

If we use the standard normal distribution, then the Z-score corresponding to 80% is 0.842

$$\text{Thus } z = 0.842 = \frac{248 - 200}{\sigma} \Rightarrow \sigma \approx 57 \Rightarrow \sigma^2 = 3253$$

Note: keep the “intermediate” answers in the calculator without rounding so that your final answer is more precise. Here for example, $57^2 = 3249!$

fx-CG50

Go to Run-Matrix app. [We set up an equation that gives us the area under the normal distribution from a lower bound (we choose (-1000 here) up to 248, and we let the standard deviation to be the unknown: SolveN(NormCD(-1000,248,x,200)=0.8)

Press $\text{ir}(\text{CALC})\text{y}(\text{SolvN})\text{d}$
 $\text{yeqw-000,248,f,200)L.0.8)1$

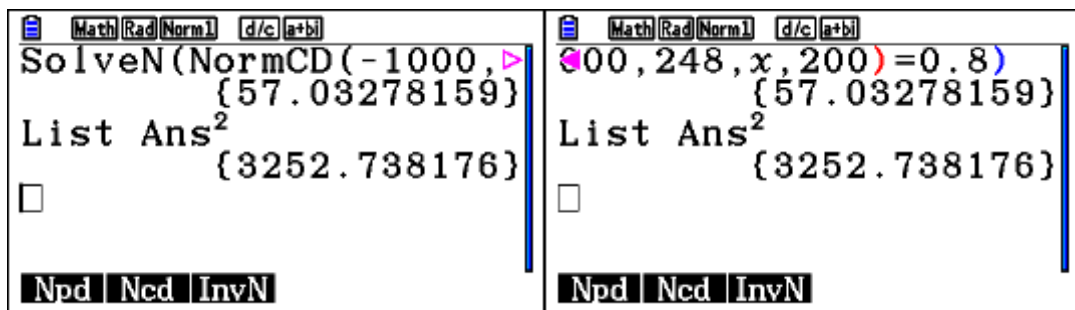

Example 7

A random variable X has a probability density function

$$f(x) = \begin{cases} 1 + 2x + ax^2 & 0 \leq x \leq 1 \\ 0 & \text{otherwise} \end{cases} \quad a \in \mathbb{R}$$

- Show that $a = -3$
- Find the median.
- Find the mean
- Find the standard deviation.
- Find the interquartile range.

Exam response:

- a. Since this is a probability density function, then

$$\int_0^1 (1 + 2x + ax^2) dx = 1$$

Thus $a = -3$

- b. Let the median be m , hence

$$\int_0^m (1 + 2x - 3x^2) dx = 0.5$$

Therefore the median is 0.403

- c. The mean is also the expected value.

$$\text{The value of the mean is } \mu = \int_{\text{all } x} xf(x) dx = \int_0^1 x(1 + 2x - 3x^2) dx \approx 0.417$$

- d. We first find the variance.

$$\begin{aligned} \text{Variance} = \sigma^2 &= \int_{\text{all } x} x^2 f(x) dx - (E(x))^2 \\ &= \int_0^1 x^2 (1 + 2x - 3x^2) dx - 0.417^2 \approx 0.0597 \end{aligned}$$

- e. Interquartile range = IQR = $Q3 - Q1$, where $Q1$, and $Q3$ are the 1st and 3rd quartiles.

Since $P(X \leq Q3) = 0.75$ and $P(X \leq Q1) = 0.25$, then we need to find M and

$$N \text{ such that } \int_0^M (1+2x-3x^2)dx = 0.75 \text{ and } \int_0^N (1+2x-3x^2)dx = 0.25$$

Thus $Q3 = 0.605$ and $Q1 = 0.214$, and therefore $IQR = 0.381$

fx-CG50

- a. Get to **Run-Matrix** app.

Press `iryrr(1+2f+affs)`

`0$1$L.1,af)1.`

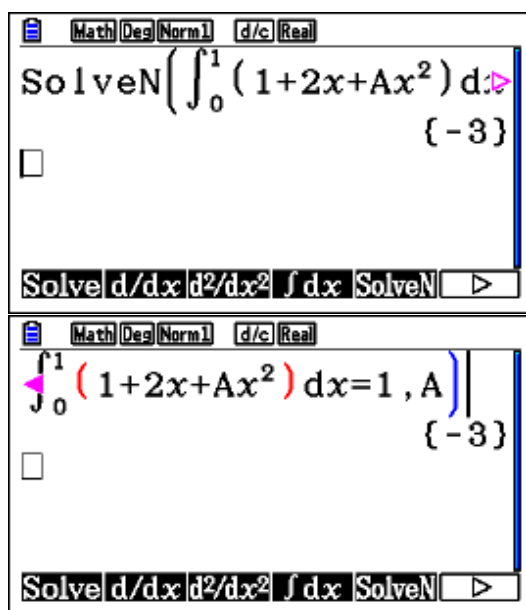

- b. Press `irydrr(1+2f-3fs)`

`0$a7$L. 0.5,a7,0,1)1.`

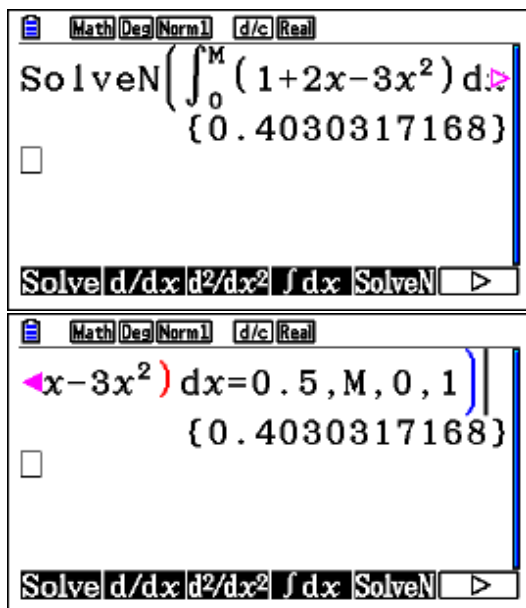

Note: we specified the values of M to be between 0 and 1 so as not to receive negative solutions too.

- c. Press `irrf(1+2f-3fs) $0$11`

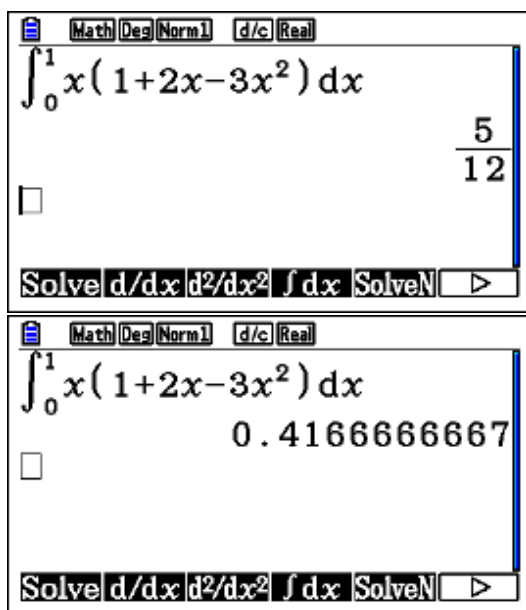

- d. You can either copy the expression above and paste it on another line and edit it, or you can type a new one in, or, you can go back and edit it as is.

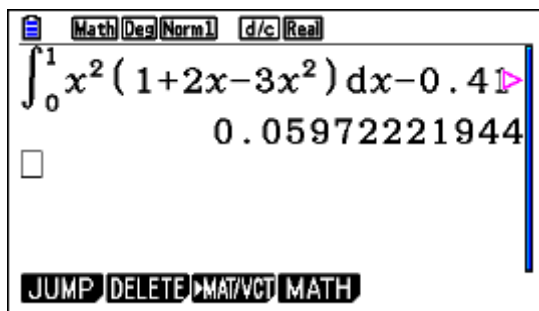

If you type it, then here is a sample:

Press `irrf(1+2f-3fs)0$1`

`-0.4172221944`

e. Find the Q3:

Press `irydr(1+2f-3fs)`

`0a7$L.0.75,a7,0,1)l.`

Find the Q1:

Press `irydr(1+2f-3fs)`

`0a8$L.0.25,a8,0,1)l.`

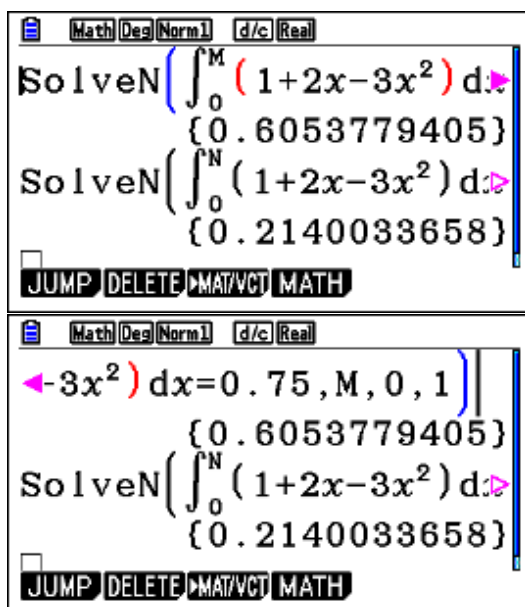

Example 8

The number of passengers waiting to travel on a train from Vienna to Bratislava every morning can be modeled by a Poisson distribution with mean 58.4.

- Find the probability that on specific morning, more than 80 passengers are waiting to take the train.
- Find the probability that during a 5-day work week more than 300 passengers wait to take this morning train.

Exam response:

- This is a Poisson cumulative probability with mean 58.4.

$$P(X > 80) = P(X \geq 81) = 0.00294$$

- This is a Poisson cumulative probability with mean $5 \times 58.4 = 292$

$$P(X > 300) = P(X \geq 301) = 0.307$$

fx-CG50

- You can do this either from the **Run-Matrix** app. Or from the **Statistics** one.

Run-Matrix

Press `iyeuqw81,1000,58.4)1`

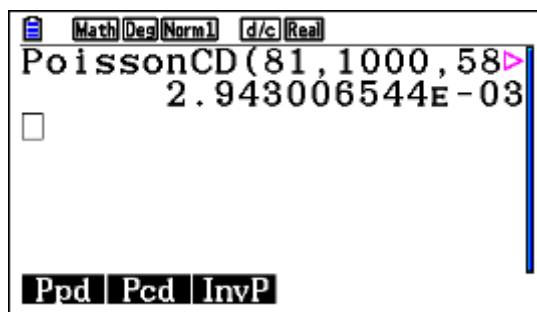

Note: the syntax is: PoissonCD(Lower limit, Upper Limit, Mean). Since this is a discrete distribution, $X > 80$ means $X = 81, 82, \dots$ etc.

Statistics

Press $\text{y}\text{u}\text{q}\text{w}\text{w}\text{N}8111000158.41$

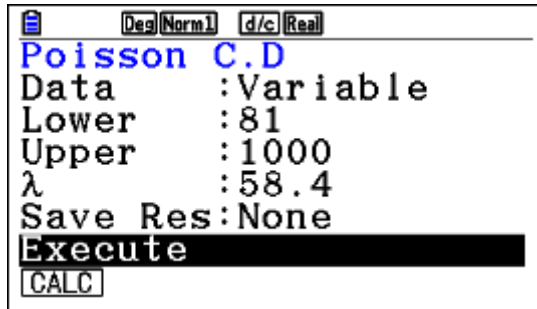

Now press Nq

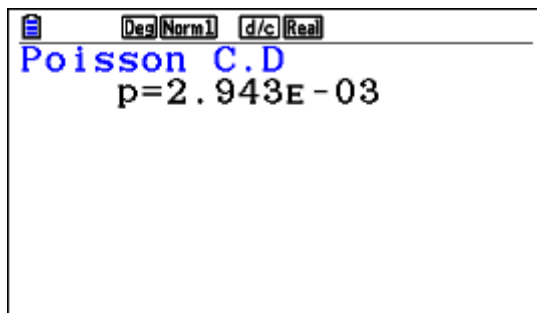

You can also put your numbers in lists as shown below

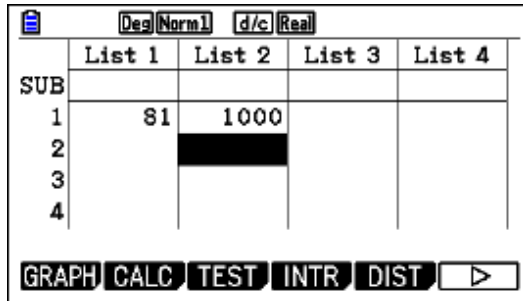

Then follow the same instructions as above

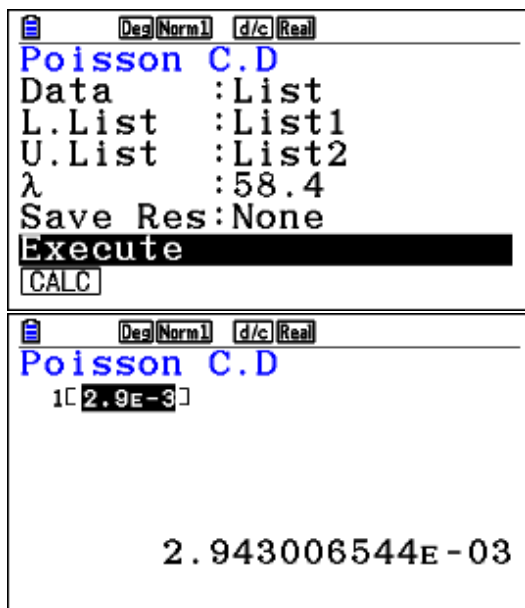

- b. This is similar. To save time, you can edit the previous command and press 1

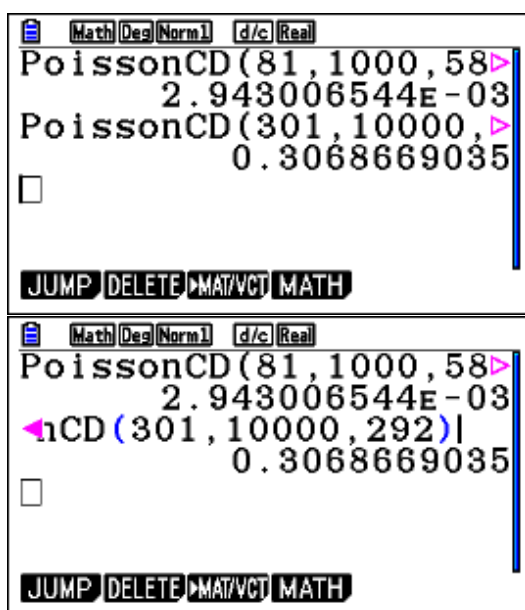

Example 9

Marco practices shooting balls into the goal from the penalty position at his school's football field. The probability that he gets any ball in is 0.60. He attempts 10 shots at the goal. We can assume that the success in an attempt is independent from the outcome of other attempts.

- a. Find the probability that he hits his target exactly 7 times.

- b. Find the probability that he hits his target at least 7 times.
- c. Find the probability that he hits his target for the first time on his 7th attempt.

Exam response:

- a. The description of the situation allows us to assume that the number of Marco's successes can be modelled by a Binomial distribution.

$$B(7, 10, 0.6) = 0.215$$

- b. To hit the target at least 7 times, $P(X \geq 7) = B(7, 10, 10, 0.6) = 0.382$

- c. The situation here is a Geometric distribution.

$$P(X = 7) = 0.00246$$

fx-CG50

- a., b. This also can be done in several ways. Either from **Run-Matrix** app. or from **Statistics** app.

Run-Matrix

For part a.

Press $\text{y}\text{e}\text{y}\text{q}7, 10, 0.6)1$, and for part b.

Press $\text{w}7, 10, 10, 0.6)1$

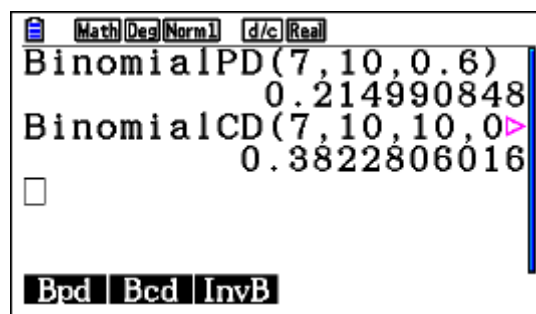

Statistics

Press $\text{y}\text{y}\text{q}\text{w}711010.61\text{N}$

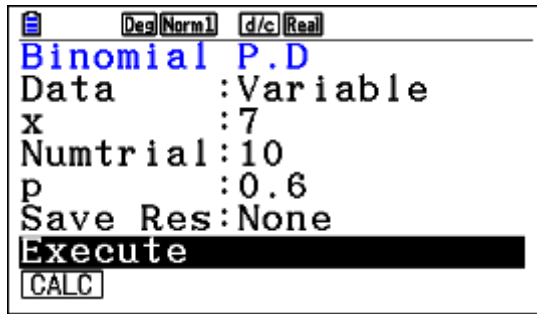

Now, either q or 1

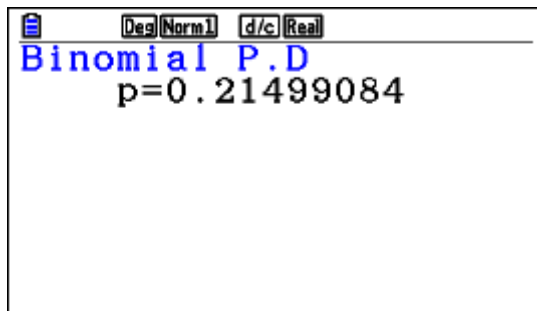

For part b. use the same procedure but choose *Bcd* instead.

- c. Also either from the **Run-Matrix** app. Or from the **Statistics** app.

Run-Matrix

Press $\text{iyewq}7, 0.6)1$

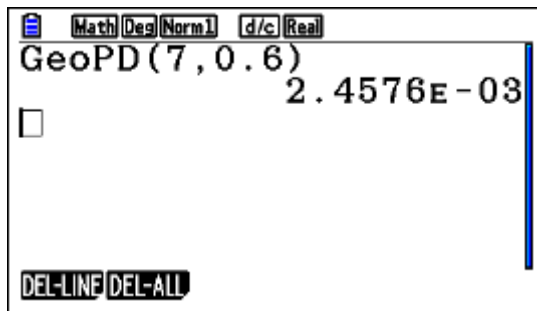

Statistics

Press $\text{yuwq}wN7)1.6Nq$ or 1

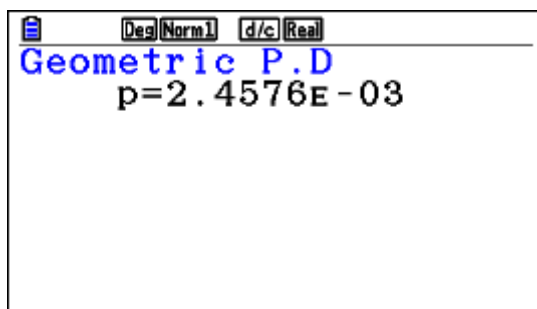

Example 10

The following table gives the average yield of coffee beans per tree, in kg, and the rainfall, in cm, for 10 separate coffee regions of Brazil. You may assume that these data are a random sample from a bivariate normal distribution, with correlation coefficient ρ .

Rainfall (x)	14	13	18	16	10	21	25	23	31	19
Yield (y)	59	56	70	64	57	81	89	91	81	72

An irrigation specialist wishes to use these data to determine whether there is a positive correlation between rainfall and yield.

- Test a suitable hypothesis and comment on the conclusion in the context of the question.
- Find the equation of the regression line of y on x .
- Hence, estimate the yield per tree in a tenth region where the rainfall was 19 cm.
- Determine the angle between the regression line of y on x and that of x on y . Give your answer to the nearest degree.

Exam response:

- (a) We need to test a hypothesis about the positive correlation of the two variables:

$$H_0 : \rho \leq 0$$

$$H_1 : \rho > 0$$

We run a t -test for correlation.

From the sample data, $r = 0.853$ and the p -value of the test is 0.000852.

Since the p -value is less than 1%, we reject the null hypothesis and conclude that we have overwhelming evidence that there is a positive correlation between rainfall and yield of coffee trees.

- (b) The regression equation is

$$Y = 1.78x + 38.2, \text{ That is Yield} = 1.78 \text{ rainfall} + 38.2$$

That is, for every increase of 1 cm in rainfall, on average the yield per tree may increase by 1.78 kg.

- (c) Yield = $1.78(19) + 38.2 = 72.00$ kg

This means that on *average* for a region with 19 cm rainfall, the expected mean yield per tree is 72 kg.

(d) If we regress x on y , then $x = 0.409y - 10.459$, and so $y = \frac{1}{0.409}x + \frac{10.459}{0.409}$

The angle between the lines is therefore $\text{Arctan}\left(\frac{1}{0.409}\right) - \text{Arctan} 1.78 \approx 7^\circ$.

fx-CG50

- (a) Go to **Statistics** app. Enter data in lists 1 and 2.

	List 1	List 2	List 3	List 4
SUB	RAINFA	YIELD		
1	14	59		
2	13	56		
3	18	70		
4	16	64		

14

GRAPH CALC TEST INTR DIST

Press \square , and then \square again to make sure that we are choosing a 1-tail test of $\rho > 0$. Make sure that the lists are appropriately assigned, and scroll down to **Execute**.

Now press either \square or \square

LinearReg tTest

$\beta > 0$ & $\rho > 0$

t = 4.62304323

p = 8.5171E-04

df = 8

a = 38.2102273

b = 1.77840909

↓
COPY

As you know, the test for the slope (gradient) of the line of regression and the correlation coefficient is the same.

- (b),(c) The test can be done through regression

From the **Statistics** app, press \square (CALC) and then \square to make sure that the lists are assigned correctly.



Press deqq

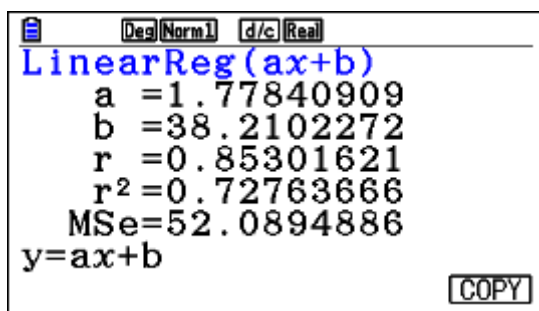

For part (c), press u to copy the equation, this will take you to the Functions screen, find an empty Y and press 1. This copies the regression equation into the chosen Y. We chose Y1 here.

Now go to **Run-Matrix** app.

Press orq1 (19) 1

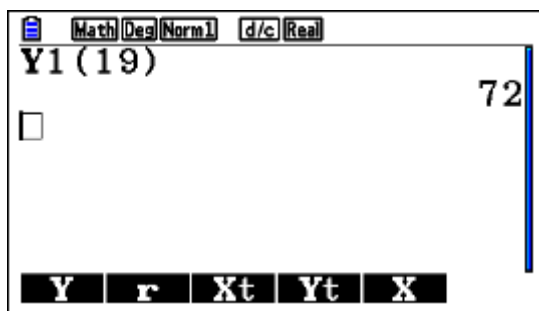

Note: Of course you can enter the expression as is in the Run-Matrix window, but there you are risking accuracy since when you enter it you will be rounding the intermediate answers!

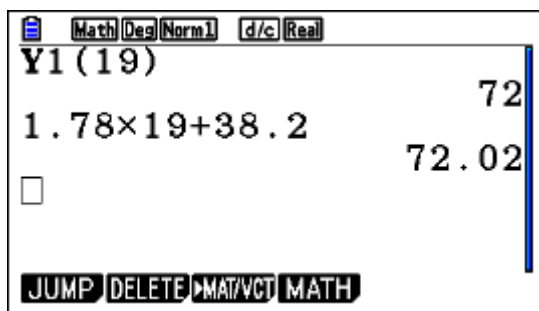

(d) We need to regress x on y now.

From the **Statistics** app, press ω (CALC) and then \cup

Make List2 as the XList.



Now press $\text{de} \ll \ll$

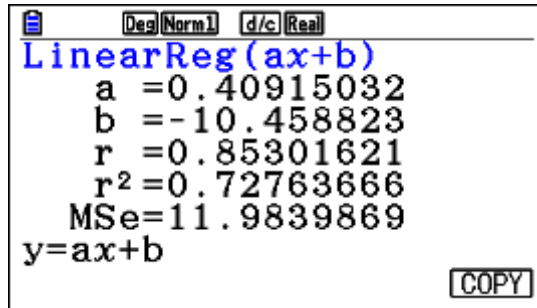

Go to **Run-Matrix** app. And evaluate the following expression making sure that the angle measure is in degrees. (You can change in SET UP.

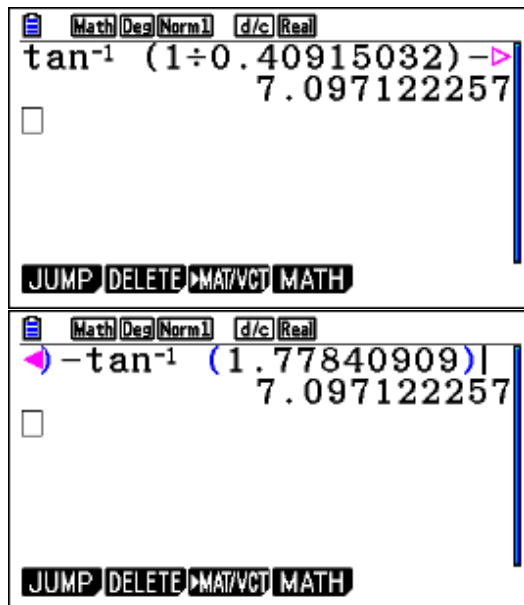

Example 11

In a certain country, scores on official exams are out of 20. During the examination session of 2015, a random sample of 20 students taking the math exams gave the following results.

$$\sum x = 280, \sum x^2 = 3977.57$$

You can consider the distribution of grades of all the students taking the exam to be normally distributed with unknown mean μ and unknown variance σ^2 .

- Find unbiased estimates of μ and σ^2 , the mean and variance of the population.
- Determine a 95 % confidence interval for μ .
- The examining board believes that the average score on this exam is at least 15 points. Test this hypothesis and state your conclusion at the 2% significance level.
- If the true average is 14.5, using the same variance above, calculate the probability of Type II error.

Exam response:

- The unbiased estimates are

$$\bar{x} = \frac{\sum x}{n} = \frac{280}{20} = 14,$$

$$s_{n-1}^2 = \left(\frac{\sum x^2}{n} - \left(\frac{\sum x}{n} \right)^2 \right) \times \frac{n}{n-1} = \left(\frac{3977.57}{20} - 14^2 \right) \times \frac{20}{19} = 3.03$$

- Since σ^2 is not known, we use the t -distribution.

A 95% confidence interval (t -interval) is [13.2, 14.8]

- We have to test the following hypothesis

$$H_0 : \mu \geq 15$$

$$H_1 : \mu < 15$$

p -value for this test is $0.00939 < 0.02$

We reject the null hypothesis and conclude that we have strong evidence that the average score of the students is below 15.

- Type II error may occur when we do not reject a false null hypothesis.

Our critical number is the number corresponding to the lower 2% of the data

Inverse t -number with 19 degrees of freedom is -2.2047

$$\text{Thus the critical number can be calculated: } -2.2047 = \frac{x-15}{\sqrt{\frac{3.03}{20}}} \Rightarrow x = 14.1419$$

$$P(\text{type II}) = P(x > 14.1419 | \text{mean} = 14.5) = P(t > -0.9201) = 0.815$$

fx-CG50

- (a) Basic operations using **Run-Matrix** app.
- (b) Go to **Statistics** app.

Press rwqwN0.951141

then Ls3.031201NN1

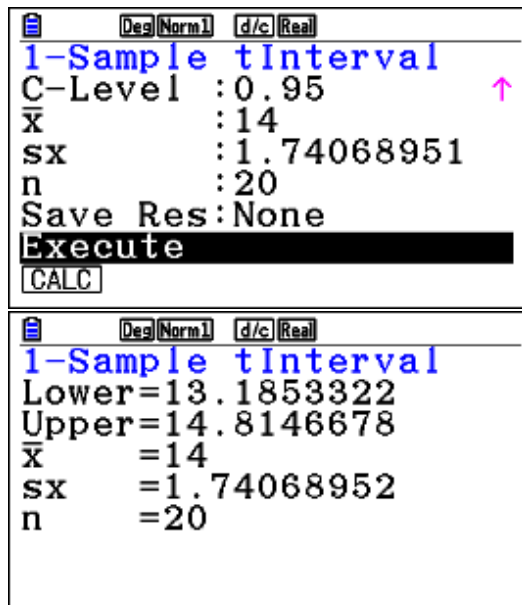

- (c) From **Statistics** app.

Press ewqwNwN151141

Then 1.74071201NNN1

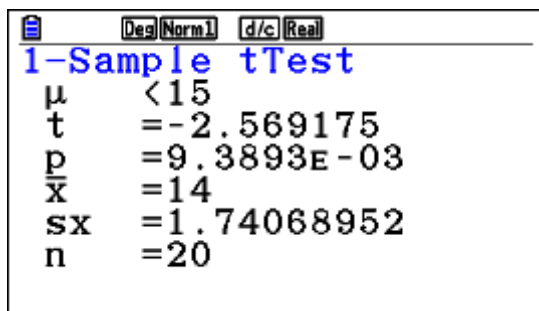

(d) From the **Statistics** app. Window

Press $\text{y}\text{wew}\text{N}0.021191\text{Nq}$

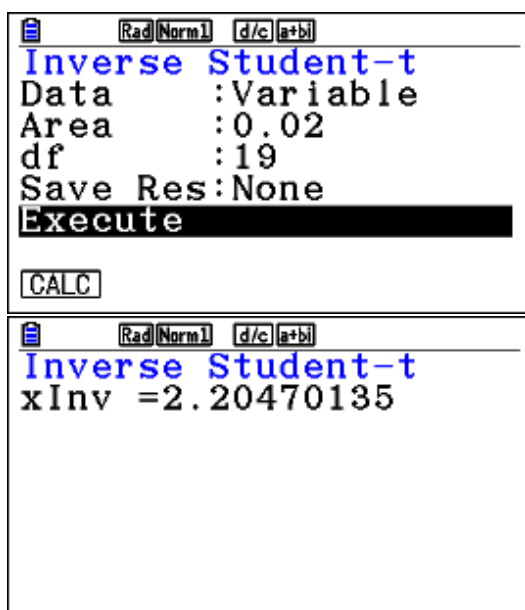

Now, from the **Run-Matrix** app window

Press iry , type the equation in, 1

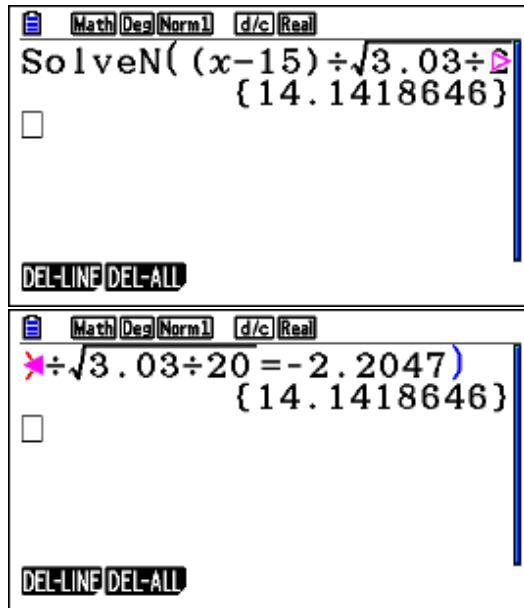

Then calculate the t -score for this number under the new mean of 14.5

This t -score is -0.9200 .

Now press $\text{iyeww}-0.92\dots$

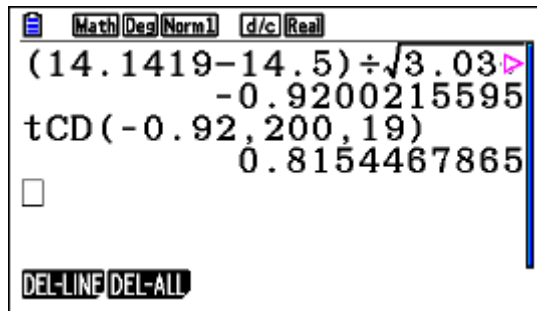

Example 12

Each day, a children's model car toy factory recorded the number (x) of boxes of cars (they pack them in boxes of 10 each) it produces and the total production cost (y) Euros. The results for 10 days are shown in the following table.

x	28	46	67	45	52	33	70	48	50	59
y	410	592	794	635	709	458	880	547	640	734

- Write down the equation of the regression line of y on x , and interpret its parameters when possible.
- Estimate the cost of producing 50 boxes.

- (c) The factory sells the boxes for 30 Euros each. Find the least number of boxes that the factory should produce in a day in order to make profit.

Exam response:

- (a) Regression of y on x : $y = 10.7x + 109$

We can interpret the gradient: On average, for every increase (decrease) of production of one box, the expected increase (decrease) of cost is 10.7 Euros. It is not appropriate to interpret the intercept because it corresponds to a value of 0 for x , which is not in the domain of x in this data set. In general it would correspond to fixed cost.

- (b) The cost estimate of 50 boxes is: $y = 10.7(50) + 109 = 642$

- (c) If the factory sells x boxes, then the revenue will be $30x$ Euros.

We find the break-even point by finding the intersection between $y = 30x$ and

$y = 10.655x + 109.272$. The minimum number of boxes will be 5.64, i.e., 6 boxes, after which the factory starts making profit.

fx-CG50

In this problem, we will demonstrate the work using the **Spreadsheet** app.

- (a) From Main menu, go to **Spreadsheet**.

Enter your data into the spreadsheet.

SHE	A	B	C	D
1	28	410		
2	46	592		
3	67	794		
4	45	635		
5	52	709		

28

FILE EDIT DELETE INSERT CLEAR ▶

Now press uw and then u again to set up the sheet.

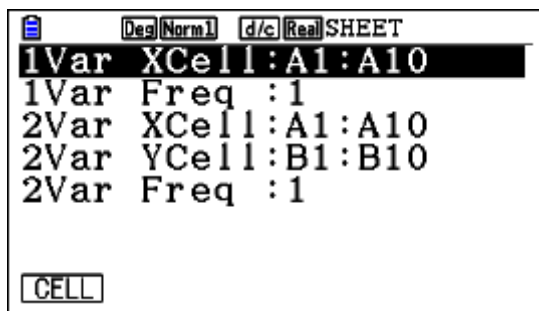

Press $\text{1e} \text{q} \text{q}$

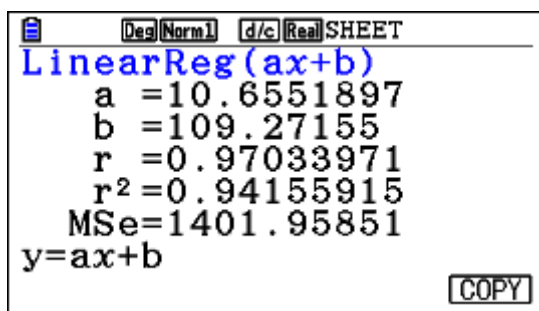

- (b) While in Regression window, press u to copy the equation, this will take you to the Graph Function window, choose an empty Y and press 1 .

Go to **Run-Matrix** app. And press $\text{or} \text{q} \text{1} (50) \text{1}$

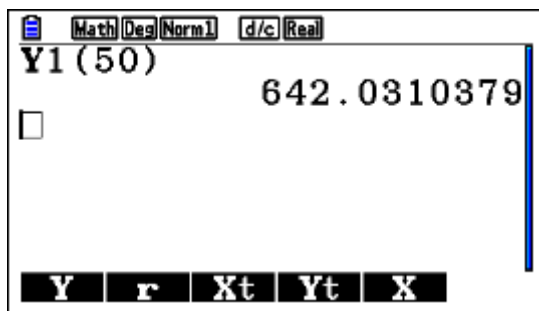

- (c) Now go to **Graph** app.. You already have the regression equation.

Enter $y = 30x$ into another Y (Y2 in this case). Press u to draw the functions, then y

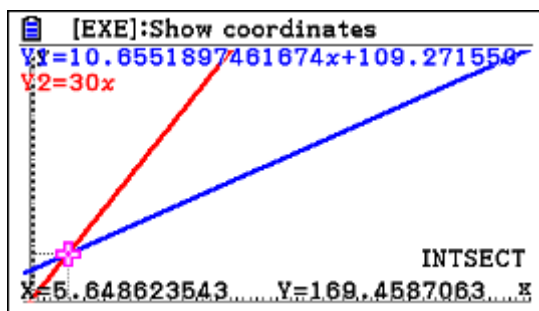

Example 13

If you buy a box of cereal XYZ your chance of winning an extra box is 20%. The company producing the cereal is trying to win a greater market share with this marketing strategy. In promoting their product they randomly insert “winning tickets” in 20% of their boxes. You own a small shop and bought 400 of these boxes.

- (a)
 - (i) Write down the mean number of winning boxes.
 - (ii) Find the standard deviation of the number of winning boxes.
- (b) Find the probability that the number of winning boxes is within one standard deviation of the mean.

Exam response:

The situation can be considered a Binomial model.

- (a)
 - (i) $\mu = 80$
 - (ii) $\sigma = \sqrt{npq} = \sqrt{400 \times 0.20 \times 0.80} = 8$
- (b) $P(80 - 8 \leq X \leq 80 + 8) = 0.712$

fx-CG50

- (a) Straightforward **Run-Matrix** operation (or even without a GDC!)

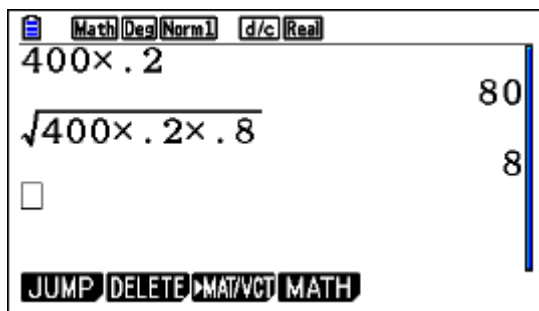

- (b) Press `iyeyw72, 88, 400, .2) 1`

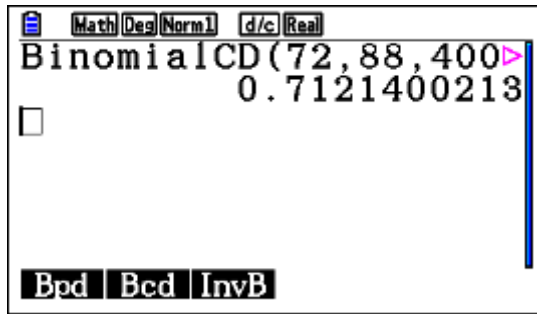

Note: If you decide to subtract two cumulative areas you have to pay attention that the lower limit is 71!

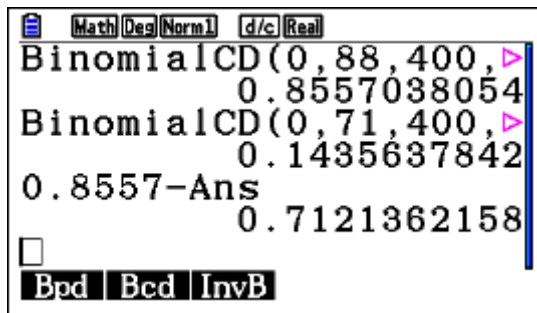

Example 14

A random variable X is normally distributed. The mean is 45 and the standard deviation is two.

It is known that $P(X > k) = 0.24$, find k .

Exam response:

The number k leaves an area of 0.24 above it. Thus we look at the Inverse Normal distribution for the number that leaves an area of 0.76 below it. $k = 46.4$.

fx-CG50

Press $\text{inv} \rightarrow \text{norm} \rightarrow 0.76, 2, 45) 1$

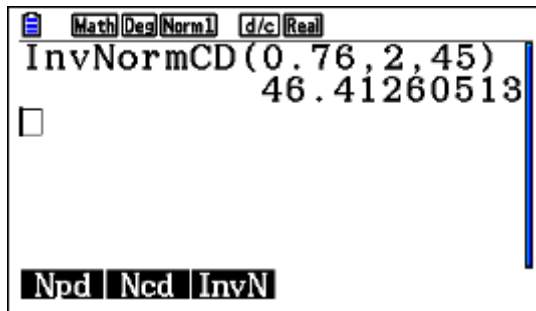

Example 15

A children clothes chain collects data concerning the sizes of clothes families buy for their children. They chose a random sample of 12 pants that families recently bought.

129, 122, 121, 118, 126, 121, 116, 124, 118, 129, 124, 117

- Find unbiased estimates of the mean and variance of the population.
- Determine a 99% confidence interval for the mean of all children buying from this shop.
- The chain manager claims that the mean size of such pants is 125, but one of the shop manager claims that the mean is less than that. Test an appropriate hypothesis at 5% level of significance.

Exam response:

(a)
$$\bar{x} = \frac{\sum x}{n} = \frac{129 + \dots + 117}{12} = 122$$

$$S_{n-1}^2 = \frac{\sum (x - \bar{x})^2}{n-1} = 19.7$$

(b) Since variance is unknown, we use the t -distribution. A 99% confidence interval is [118, 126].

(c) $H_0 : \mu = 125; H_1 : \mu < 125$

The p -value of this test is $0.0220 < 5\%$. We reject the null hypothesis and conclude that the shop manager rather than the chain manager is correct.

fx-CG50

(a) Enter the data into a list

	List 1	List 2	List 3	List 4
SUB SIZE				
1	129			
2	122			
3	121			
4	118			

Press wu set the correct list

1Var	XList	: List1
1Var	Freq	: 1
2Var	XList	: List1
2Var	YList	: List2
2Var	Freq	: 1

LIST

Now dq

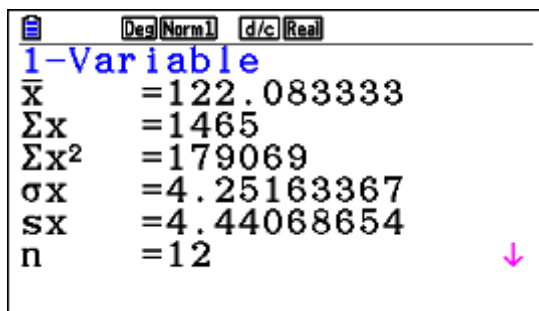

- (b) While in the “List” window, press rwq then q to choose **List** rather than **variable**. Choose confidence level if it is not 0.95, and scroll down to **Execute** and press 1

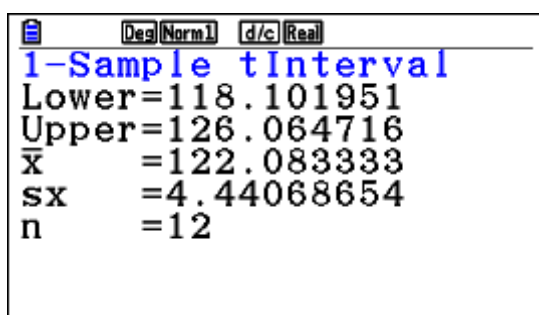

- (c) Again from the List window, press ewq , make sure the data is correctly entered as shown

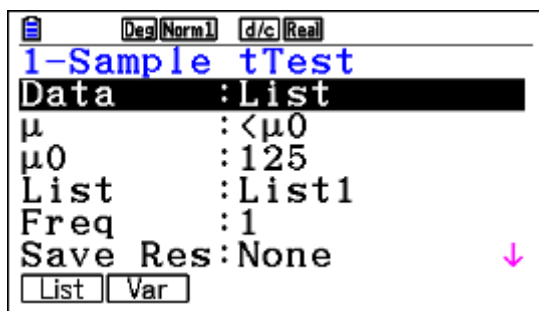

Scroll down to **Execute** and press 1 or q

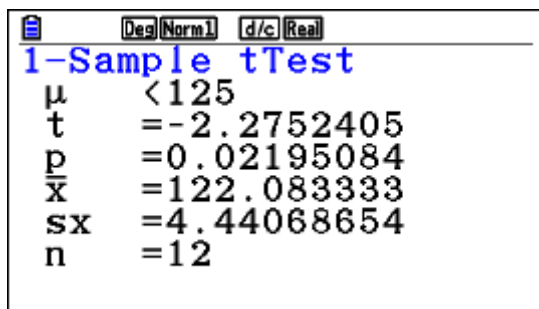

Example 16

In a study of the difference of weights of 18-20 years old young males and females in a certain country found that the weights are normally distributed, the males with mean 75 kg and standard deviation 7.5 kg and the females with mean 60 kg and standard deviation 5 kg.

- (a) Find the probability that the weight of a randomly selected male is more than twice the weight of a randomly selected female.
- (b) Two males and five females stand together on a weighing machine. Find the probability that their total weight is less than 400 kg.

Exam response:

- (a) Given that $M \sim N(75, 7.5^2)$ and $F \sim N(60, 25)$.

We let $X = M - 2F \Rightarrow X \sim N(-45, 156.25)$

Find $P(X > 0)$.

$$P(X > 0 | N(-45, 156.25)) = 0.000159$$

- (b) let; $Y = M_1 + M_2 + F_1 + \dots + F_5$; $Y \sim N(450, 237.5)$

$$P(Y < 400 | N(450, 237.5)) = 0.000588$$

Note: This question requires that you remember how to combine random variables. For example, If $Z = X - 2Y$, then $E(Z) = E(X) - 2E(Y)$ and

$Var(Z) = Var(x) + 4Var(Y)$. While if $Z = X_1 + X_2 + Y_1 + \dots + Y_5$ then

$E(Z) = 2E(X) + 5E(Y)$ and $Var(Z) = 2Var(x) + 5Var(Y)$

fx-CG50

- (a) In the **Run-Matrix** app.

Press `iyewq0,1000,156n45)1`

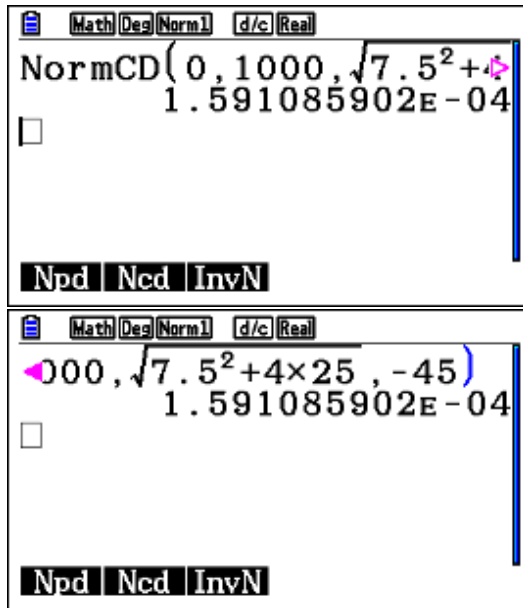

(b) Repeat the above with different numbers

